



P O L S K A N O R M A

ICS 77.040.10

PN-EN ISO 16859-1

Wprowadza
EN ISO 16859-1:2015, IDT
ISO 16859-1:2015, IDT

Zastępuje

–

Metale

Pomiar twardości sposobem Leeba

Część 1: Metoda badań

Norma Europejska EN ISO 16859-1:2015 *Metallic materials – Leeb hardness test – Part 1: Test method (ISO 16859-1:2015)* ma status Polskiej Normy

© Copyright by PKN, Warszawa 2015

nr ref. PN-EN ISO 16859-1:2015-12

Wszelkie prawa autorskie zastrzeżone. Żadna część niniejszej publikacji nie może być zwielokrotniana jakkolwiek techniką bez pisemnej zgody Prezesa Polskiego Komitetu Normalizacyjnego

ISBN 978-83-275-5333-1

PN-EN ISO 16859-1:2015-12

Przedmowa krajowa

Niniejsza norma została zatwierdzona przez Prezesa PKN dnia 3 grudnia 2015 r.

Komitetem krajowym odpowiedzialnym za normę jest KT nr 123 ds. Badań Własności Metali.

Istnieje możliwość przetłumaczenia normy na język polski na wniosek zainteresowanych środowisk. Decyzję podejmuje właściwy Komitet Techniczny.

Odpowiedniki krajowe norm i innych dokumentów powołanych w niniejszej normie można znaleźć w katalogu Polskich Norm. Oryginały norm i innych dokumentów powołanych są dostępne w PKN.

W sprawach merytorycznych dotyczących treści normy można zwracać się do właściwego Komitetu Technicznego lub właściwej Rady Sektorowej PKN, kontakt: www.pkn.pl

Nota uznaniowa

Norma Europejska EN ISO 16859-1:2015 została uznana przez PKN za Polską Normę PN-EN ISO 16859-1:2015-12.

EUROPEAN STANDARD

EN ISO 16859-1

NORME EUROPÉENNE

EUROPÄISCHE NORM

October 2015

ICS 77.040.10

English Version

Metallic materials - Leeb hardness test - Part 1: Test method (ISO 16859-1:2015)

Matériaux métalliques - Essai de dureté Leeb - Partie 1
: Méthode d'essai (ISO 16859-1:2015)

Metallische Werkstoffe - Härteprüfung nach Leeb - Teil
1: Prüfverfahren (ISO 16859-1:2015)

This European Standard was approved by CEN on 10 July 2015.

CEN members are bound to comply with the CEN/CENELEC Internal Regulations which stipulate the conditions for giving this European Standard the status of a national standard without any alteration. Up-to-date lists and bibliographical references concerning such national standards may be obtained on application to the CEN-CENELEC Management Centre or to any CEN member.

This European Standard exists in three official versions (English, French, German). A version in any other language made by translation under the responsibility of a CEN member into its own language and notified to the CEN-CENELEC Management Centre has the same status as the official versions.

CEN members are the national standards bodies of Austria, Belgium, Bulgaria, Croatia, Cyprus, Czech Republic, Denmark, Estonia, Finland, Former Yugoslav Republic of Macedonia, France, Germany, Greece, Hungary, Iceland, Ireland, Italy, Latvia, Lithuania, Luxembourg, Malta, Netherlands, Norway, Poland, Portugal, Romania, Slovakia, Slovenia, Spain, Sweden, Switzerland, Turkey and United Kingdom.



EUROPEAN COMMITTEE FOR STANDARDIZATION
COMITÉ EUROPÉEN DE NORMALISATION
EUROPÄISCHES KOMITEE FÜR NORMUNG

CEN-CENELEC Management Centre: Avenue Marnix 17, B-1000 Brussels

EN ISO 16859-1:2015 (E)

Contents

Page

European foreword.....	3
-------------------------------	----------

European foreword

This document (EN ISO 16859-1:2015) has been prepared by Technical Committee ISO/TC 164 “Mechanical testing of metals” in collaboration with Technical Committee ECISS/TC 101 “Test methods for steel (other than chemical analysis)” the secretariat of which is held by AFNOR.

This European Standard shall be given the status of a national standard, either by publication of an identical text or by endorsement, at the latest by April 2016, and conflicting national standards shall be withdrawn at the latest by April 2016.

Attention is drawn to the possibility that some of the elements of this document may be the subject of patent rights. CEN [and/or CENELEC] shall not be held responsible for identifying any or all such patent rights.

According to the CEN-CENELEC Internal Regulations, the national standards organizations of the following countries are bound to implement this European Standard: Austria, Belgium, Bulgaria, Croatia, Cyprus, Czech Republic, Denmark, Estonia, Finland, Former Yugoslav Republic of Macedonia, France, Germany, Greece, Hungary, Iceland, Ireland, Italy, Latvia, Lithuania, Luxembourg, Malta, Netherlands, Norway, Poland, Portugal, Romania, Slovakia, Slovenia, Spain, Sweden, Switzerland, Turkey and the United Kingdom.

Endorsement notice

The text of ISO 16859-1:2015 has been approved by CEN as EN ISO 16859-1:2015 without any modification.

INTERNATIONAL
STANDARD

ISO
16859-1

First edition
2015-09-15

**Metallic materials — Leeb hardness
test —**

**Part 1:
Test method**

*Matériaux métalliques — Essai de dureté Leeb —
Partie 1: Méthode d'essai*



Reference number
ISO 16859-1:2015(E)

© ISO 2015

ISO 16859-1:2015(E)



COPYRIGHT PROTECTED DOCUMENT

© ISO 2015, Published in Switzerland

All rights reserved. Unless otherwise specified, no part of this publication may be reproduced or utilized otherwise in any form or by any means, electronic or mechanical, including photocopying, or posting on the internet or an intranet, without prior written permission. Permission can be requested from either ISO at the address below or ISO's member body in the country of the requester.

ISO copyright office
Ch. de Blandonnet 8 • CP 401
CH-1214 Vernier, Geneva, Switzerland
Tel. +41 22 749 01 11
Fax +41 22 749 09 47
copyright@iso.org
www.iso.org

Contents

Page

Foreword	iv
1 Scope	1
2 Normative references	1
3 Principle	1
4 Symbols, abbreviated terms, and designations	1
5 Testing instrument	3
6 Test piece	3
6.1 Shape.....	3
6.2 Thickness and mass.....	3
6.3 Surface preparation.....	4
7 Procedure	4
8 Uncertainty of the results	6
9 Test report	6
10 Conversions to other hardness scales or tensile strength values	6
Annex A (normative) Tables of correction factors for use in tests not conducted in direction of gravity	7
Annex B (normative) Procedure for periodic checking of testing instrument by the user	11
Annex C (informative) Uncertainty of the measured Leeb hardness values	12
Annex D (informative) Leeb hardness testing instruments	18
Bibliography	20

ISO 16859-1:2015(E)

Foreword

ISO (the International Organization for Standardization) is a worldwide federation of national standards bodies (ISO member bodies). The work of preparing International Standards is normally carried out through ISO technical committees. Each member body interested in a subject for which a technical committee has been established has the right to be represented on that committee. International organizations, governmental and non-governmental, in liaison with ISO, also take part in the work. ISO collaborates closely with the International Electrotechnical Commission (IEC) on all matters of electrotechnical standardization.

The procedures used to develop this document and those intended for its further maintenance are described in the ISO/IEC Directives, Part 1. In particular the different approval criteria needed for the different types of ISO documents should be noted. This document was drafted in accordance with the editorial rules of the ISO/IEC Directives, Part 2 (see www.iso.org/directives).

Attention is drawn to the possibility that some of the elements of this document may be the subject of patent rights. ISO shall not be held responsible for identifying any or all such patent rights. Details of any patent rights identified during the development of the document will be in the Introduction and/or on the ISO list of patent declarations received (see www.iso.org/patents).

Any trade name used in this document is information given for the convenience of users and does not constitute an endorsement.

For an explanation on the meaning of ISO specific terms and expressions related to conformity assessment, as well as information about ISO's adherence to the WTO principles in the Technical Barriers to Trade (TBT) see the following URL: [Foreword - Supplementary Information](#)

The committee responsible for this document is ISO/TC 164, *Mechanical testing of metals*, Subcommittee SC 3, *Hardness testing*.

ISO 16859 consists of the following parts, under the general title *Metallic materials — Leeb hardness test*:

- *Part 1: Test method*
- *Part 2: Verification and calibration of the testing devices*
- *Part 3: Calibration of reference test blocks*

Metallic materials — Leeb hardness test —

Part 1: Test method

1 Scope

This part of ISO 16859 covers the determination of a dynamic hardness of metallic materials using seven different Leeb scales (HLD, HLS, HLE, HLDL, HLD+15, HLC, HLG).

2 Normative references

The following documents, in whole or in part, are normatively referenced in this document and are indispensable for its application. For dated references, only the edition cited applies. For undated references, the latest edition of the referenced document (including any amendments) applies.

ISO 16859-2, *Metallic materials — Leeb hardness test — Part 2: Verification and calibration of the testing devices*

ISO 16859-3, *Metallic materials — Leeb hardness test — Part 3: Calibration of reference test blocks*

3 Principle

When testing hardness according to Leeb, a moving impact body collides at normal incidence with a surface and rebounds. The velocity of the impact body is measured before (v_A) and after impact (v_R). The energy amount absorbed by the test piece respectively dissipated in the test measures the dynamic Leeb hardness of the test piece. It is assumed that the impact body does not permanently deform.

The ratio of the impact and rebound velocity values gives the coefficient of restitution for the impact configuration and energy used. This coefficient represents the proportion of initial kinetic energy returned to the impact body within the contact time of the impact.

The hardness number according to Leeb, HL, is calculated as given in Formula (1)

$$HL = \frac{v_R}{v_A} \cdot 1\,000 \quad (1)$$

where

v_R is rebound velocity;

v_A is impact velocity.

By definition, the Leeb hardness is a ratio and thus becomes a quantity without dimensions.

4 Symbols, abbreviated terms, and designations

4.1 For most common Leeb scale and type of impact devices, see [Table 1](#).

NOTE Other parameter values can be used based on the specific agreement between the parties.

ISO 16859-1:2015(E)

Table 1 — Symbols, dimensions, designations, and parameters of Leeb scales according to type of impact devices

Symbol	Unit	Designation	Parameters of types of impact devices						
			D ^a	S	E	DL	D+15	C	G
E_A	mJ	Kinetic impact energy ^b	11,5	11,4	11,5	11,95	11,2	3,0	90,0
v_A	m/s	Impact velocity	2,05	2,05	2,05	1,82	1,7	1,4	3,0
v_R	m/s	Rebound velocity	0,615 - 1,824 5	0,82 - 1,886	0,615 - 1,886	1,1092 - 1,729	0,561 - 1,513	0,49 - 1,344	0,9 - 2,25
	mm	Maximum distance of ball indenter from test piece surface at velocity measurement	2,00	2,00	2,00	2,00	2,00	2,00	3,00
M	g	Mass of impact body incl. ball indenter	5,45	5,40	5,45	7,25	7,75	3,1	20,0
R	mm	Spherical radius of indenter ball	1,5	1,5	1,5	1,39	1,5	1,5	2,5
		Material of indenter	WC-Co ^c	C ^d	PCD ^e	WC-Co ^c	WC-Co ^c	WC-Co ^c	WC-Co ^c
HL		Leeb hardness	HLD	HLS	HLE	HLDL	HLD+15	HLC	HLG
		Field of application	300 HLD - 890 HLD	400 HLS - 920 HLS	300 HLE - 920 HLE	560 HLDL - 950 HLDL	330 HLD+15 - 890 HLD+15	350 HLC - 960 HLC	300 HLG - 750 HLG
^a Alternative common designation "DC". ^b Impact vertically down, in direction of gravity, rounded. ^c Tungsten-carbide cobalt. ^d Ceramics. ^e Polycrystalline diamond.									

4.2 The Leeb hardness number is followed by the symbol "HL" with one or more subsequent characters representing the type of impact device.

EXAMPLE 570 HLD

Leeb hardness, HL, is measured using impact device type D in direction of gravity. Measurements using a different impact device type will deliver a different hardness number, as the result from Formula (1) depends on the parameters of each impact device type.

For testing in other directions, the measured hardness number will be biased. In such cases, a correction shall be applied in accordance with [Annex A](#). If the test is not conducted in direction of gravity, the testing direction and correction shall be recorded, and the adjusted hardness number shall be given as the Leeb hardness result.

5 Testing instrument

5.1 The instrument used for Leeb hardness testing consists of an impact device (for an example, see [Annex D](#)) and an electronic measuring and indicating unit to determine the impact and rebound velocity of the impact body.

5.2 The impact body consists of a spherical indenter and the holder of the indenter, see [Table 1](#).

5.3 The support ring shall be mounted tightly to the bottom of the impact device. Except for impact device type DL, the support surface shall be designed to prevent movement of the impact device during the test.

The support ring should be checked regularly, as wear can affect the readings. Specifically, the bottom surface of the support ring should be visually inspected. Deposits and dirt should be removed.

5.4 The instrument shall meet the requirements of ISO 16859-2.

6 Test piece

6.1 Shape

6.1.1 Leeb hardness testing can be done on test pieces of diverse shapes as long as the impact velocity vector is normal to the local surface region to be tested, and the support ring is stably placed on the test piece surface.

6.1.2 Test pieces with curved surfaces (concave or convex) can be tested providing that the radius of curvature at the test location is not less than 50 mm for the impact device type G, or 30 mm for other impact devices, respectively.

6.1.3 In all other cases, special support rings shall be used for a stable seating of the instrument on the test surface.

6.2 Thickness and mass

The stiffness of the test piece, which is often determined by the local thickness and the mass of the test piece, shall be considered when selecting the impact device to be employed (see [Table 2](#)).

NOTE 1 Failure to provide adequate support will produce incorrect test results.

NOTE 2 Test pieces of mass less than the minimum indicated mass or pieces of sufficient mass with sections less than the minimum thickness require rigid support and/or coupling to a solid supporting body. Coupling refers to a method where the test piece is firmly connected to a much heavier support without straining or stressing the test piece. For example, an adhesive film can be applied between the test piece surface and the heavy support. This combination presents a larger combined mass to resist the impinging impact body. The coupling method can be used after comparison of the results with an uncoupled reference test piece of sufficient mass and thickness.

ISO 16859-1:2015(E)

Table 2 — Mass and thickness requirements of test piece

Type of impact devices	Minimum mass (no rigid support)	Minimum mass (rigid support)	Minimum thickness (uncoupled)	Minimum thickness (coupled)
	kg	kg	mm	mm
D, DL, D+15, S, E	5	2	25	3
G	15	5	70	10
C	1,5	0,5	10	1

NOTE 3 Special geometries of the test piece, e.g. thin slabs or tube surfaces, can require additional support of the test location to also permit testing where the thickness of the test piece can be smaller than the minimum thickness given in Table 2. For example on tubes, the support requirement can be expressed in terms of the ratio of the tube diameter, D , to its wall thickness, s , (see References [2] to [4]), which is a measure of the sample stiffness. If no support can be applied, correction factors to the measured values can be determined in dependence of D/s (see Reference [4]).

6.3 Surface preparation

The test surface shall be carefully prepared to avoid any alterations in hardness caused by heating during grinding or by work hardening during machining. It is recommended that the test surface be machined and polished to the surface finish as defined in Table 3. Any coatings, scale, contaminants, or other surface irregularities shall be completely removed. The surface shall be free from lubricants. The surface locations to be tested should not exceed the arithmetical mean roughness values, R_a , (also “centre line average”) (see Reference [5]) given in Table 3 for each impact device (see References [2] or [4]).

Table 3 — Recommended surface finish R_a

Type of impact device	Maximum arithmetical mean surface roughness R_a μm
D, DL, D+15, S, E	2,0
G	7,0
C	0,4

7 Procedure

7.1 The daily verification defined in Annex B shall be performed before the first test of each day for each scale used.

7.2 In general, the test should be carried out at ambient temperature within the limits of 10 °C to 35 °C. However, because temperature variation can affect the results, users of the Leeb test can choose to control the temperature within a tighter range, such as 23 °C ± 5 °C.

NOTE The temperature of the test material and the temperature of the hardness testing instrument can affect the test results. The test temperature can adversely affect the hardness measurement.

7.3 Magnetic fields at the test location can affect the results of Leeb tests and must be avoided. Leeb hardness tests can be found particularly susceptible to ambient electromagnetic fields in the frequency range of a few kHz.

7.4 The test piece and impact device shall not be moved during a test. The supporting surface shall be clean and free from contaminants (scale, lubricants, dirt, etc.).

7.5 Vibration and relative motion of the test piece or the impact device during a Leeb test can affect the test result and must be avoided.

7.6 An impact is best carried out when the distance between the centre of an indentation and the edge of the test piece permits placement of the entire support ring on the test piece. In no case shall the distance between impact point and edge of the test piece be less than 10 mm for impact device G, and 5 mm for impact devices D, DL, D+15, C, S, and E.

7.7 The distance between any two adjacent indentations centre-to-centre shall be at least three times the diameter of the indentation. [Table 4](#) gives the typical indentation diameters at various hardness levels for the different types of impact devices.

NOTE As a practical estimation, this requirement will be met if the edge-to-edge distance between any two adjacent indentations is at least two times the diameter of the larger indentation.

Table 4 — Examples of typical indentation sizes on steel of various hardness

Type of impact devices	Approximate diameters		
	low hardness	mid hardness	high hardness
D	0,54 mm at ~ 570 HLD	0,45 mm at ~ 760 HLD	0,35 mm at ~ 840 HLD
DL	0,54 mm at ~ 760 HL DL	0,45 mm at ~ 880 HL DL	0,35 mm at ~ 925 HL DL
D+15	0,54 mm at ~ 585 HLD+15	0,45 mm at ~ 765 HLD+15	0,35 mm at ~ 845 HLD+15
S	0,54 mm at ~ 610 HLS	0,45 mm at ~ 800 HLS	0,35 mm at ~ 875 HLS
E	0,54 mm at ~ 540 HLE	0,45 mm at ~ 725 HLE	0,35 mm at ~ 805 HLE
G	1,03 mm at ~ 535 HLG	0,9 mm at ~ 710 HLG	— ^a
C	0,38 mm at ~ 635 HLC	0,32 mm at ~ 820 HLC	0,3 mm at ~ 900 HLC
^a Out of typical application range.			

7.8 The impact device shall be held perpendicular to the surface of the test piece.

Prior to a test, the correct instrument set-up and settings in accordance with the manufacturer instructions shall be verified. Any deviations exceeding 5° from the direction of gravity entail measurement errors. For impact directions not in the direction of gravity, the test values shall be adjusted (see [4.2](#) and [Annex A](#)).

7.9 In its loaded state, the impact device shall be snugly placed on the prepared test surface, and the impact triggered. Impact and rebound velocity are determined by the measuring and indicating unit and a Leeb hardness number HL be generated.

7.10 To determine the Leeb hardness, the arithmetic mean value from at least three readings shall be calculated. If the span of three readings exceeds 5 % of the arithmetic mean value, then additional measurements shall be made to provide an average of at least 10 readings.

ISO 16859-1:2015(E)

8 Uncertainty of the results

The uncertainty of the results depends on the various sources of uncertainty. These can be divided into two categories:

- sources dependent on the Leeb hardness testing instrument (including the measurement uncertainty from the direct calibration of the instrument) as well as the calibration of the reference test block;
- sources dependent on the test method and varying testing conditions.

The permissible error of the testing instrument from ISO 16859-2:2015, Table 3 can be used to estimate the expanded measurement uncertainty.

NOTE 1 A thorough evaluation of the uncertainty of measurement can be performed following Reference [6].

NOTE 2 Sometimes it is not possible to quantify each aspect contributing to the uncertainty of measurement. However, an estimate of the uncertainty of measurement can be derived from the statistical analysis of multiple measurements on the test piece.

An example for the estimation of the uncertainty of Leeb hardness measurements is given in [Annex C](#).

9 Test report

At minimum, the test report shall contain the following information:

- a) a reference to this part of ISO 16859, i.e. ISO 16859-1;
- b) the essential details to identify the test piece;
- c) specification of the testing instrument (type of impact device);
- d) measurement result and number of underlying single readings;
- e) any significant details of the test that are not determined by this part of ISO 16859 or that have been applied by reasoning, e.g. way of coupling, test location on the test piece, impact direction with reference to gravity;
- f) any events or peculiarities that could have had an impact on the measurement;
- g) test temperature if it is not within the limits of 10 °C to 35 °C.

10 Conversions to other hardness scales or tensile strength values

There is no general process for accurately converting Leeb hardness into other Leeb hardness scales or non-Leeb hardness scales, respectively, or Leeb hardness into tensile strength. Such conversions, therefore, should be avoided, unless a reliable basis for conversion can be obtained by comparison tests.

If it is necessary to check a given Leeb hardness value against a value gained by a different test method, conversion from one hardness value to another or from a hardness value to a tensile strength value can be obtained through a reliable basis of data from comparison tests. Conversions involve uncertainties which must be taken into account. This situation is described in ISO 18265 (see Reference [7]).

ASTM-International E140 (see Reference [8]) includes conversions from Leeb hardness to other hardness scales for a group of steels. There is also a study of the relationship between Leeb hardness and Vickers hardness (see Reference [9]).

Annex A (normative)

Tables of correction factors for use in tests not conducted in direction of gravity

Tables A.1 to A.7 (see Reference [10]) give the correction values when tests are not made in direction of gravity. The correction values are tabulated in terms of the angle θ . The correction depends on $\cos \theta$, where θ is the angle between the impact direction and the direction of gravity, and the measured hardness value.

NOTE For any given angles not shown in the table, the user can interpolate to obtain the correction value.

EXAMPLE Impact direction upwards, at an angle of $\theta = 135^\circ$ to the direction of gravity.

Impact device, type D

Measurement value, 725 HLD

Correction value (from Table A.1), -12 HLD

Hardness of test piece = 725 HLD - 12 HLD = 713 HLD

NOTE The tables given in this Annex are originally copyrighted by Proceq SA 1985. The tables are reprinted here by permission of Proceq SA.

Table A.1 — Impact direction corrections, impact device type D

Measured hardness HLD	Correction HLD			
	Impact direction $\theta = 45^\circ$	Impact direction $\theta = 90^\circ$	Impact direction $\theta = 135^\circ$	Impact direction $\theta = 180^\circ$
300 ≤ HLD < 350	-6	-12	-20	-29
350 ≤ HLD < 400	-6	-12	-19	-27
400 ≤ HLD < 450	-5	-11	-18	-25
450 ≤ HLD < 500	-5	-10	-17	-24
500 ≤ HLD < 550	-5	-10	-16	-22
550 ≤ HLD < 600	-4	-9	-15	-20
600 ≤ HLD < 650	-4	-8	-14	-19
650 ≤ HLD < 700	-4	-8	-13	-18
700 ≤ HLD < 750	-3	-7	-12	-17
750 ≤ HLD < 800	-3	-6	-11	-16
800 ≤ HLD < 850	-3	-6	-10	-15
850 ≤ HLD < 890	-2	-5	-9	-14

ISO 16859-1:2015(E)

Table A.2 — Impact direction corrections, impact device type S

Measured hardness HLS	Correction HLS			
	Impact direction $\theta = 45^\circ$	Impact direction $\theta = 90^\circ$	Impact direction $\theta = 135^\circ$	Impact direction $\theta = 180^\circ$
$400 \leq \text{HLS} < 450$	-4	-9	-16	-23
$450 \leq \text{HLS} < 500$	-4	-8	-15	-22
$500 \leq \text{HLS} < 550$	-4	-8	-14	-21
$550 \leq \text{HLS} < 600$	-4	-7	-13	-19
$600 \leq \text{HLS} < 650$	-3	-7	-12	-18
$650 \leq \text{HLS} < 700$	-3	-7	-12	-16
$700 \leq \text{HLS} < 750$	-3	-6	-11	-15
$750 \leq \text{HLS} < 800$	-3	-6	-10	-14
$800 \leq \text{HLS} < 850$	-3	-5	-9	-12
$850 \leq \text{HLS} < 900$	-2	-5	-8	-11
$900 \leq \text{HLS} < 920$	-2	-5	-7	-10

Table A.3 — Impact direction corrections, impact device type E

Measured hardness HLE	Correction HLE			
	Impact direction $\theta = 45^\circ$	Impact direction $\theta = 90^\circ$	Impact direction $\theta = 135^\circ$	Impact direction $\theta = 180^\circ$
$300 \leq \text{HLE} < 350$	-5	-9	-18	-26
$350 \leq \text{HLE} < 400$	-4	-9	-17	-24
$400 \leq \text{HLE} < 450$	-4	-9	-16	-22
$450 \leq \text{HLE} < 500$	-4	-8	-15	-21
$500 \leq \text{HLE} < 550$	-4	-8	-14	-20
$550 \leq \text{HLE} < 600$	-4	-8	-13	-18
$600 \leq \text{HLE} < 650$	-3	-7	-12	-17
$650 \leq \text{HLE} < 700$	-3	-7	-12	-16
$700 \leq \text{HLE} < 750$	-3	-6	-11	-15
$750 \leq \text{HLE} < 800$	-3	-6	-10	-14
$800 \leq \text{HLE} < 850$	-3	-5	-9	-13
$850 \leq \text{HLE} < 920$	-2	-5	-8	-12

Table A.4 — Impact direction corrections, impact device type DL

Measured hardness HLDL	Correction HLDL			
	Impact direction $\theta = 45^\circ$	Impact direction $\theta = 90^\circ$	Impact direction $\theta = 135^\circ$	Impact direction $\theta = 180^\circ$
$560 \leq \text{HLDL} < 600$	-3	-6	-11	-16
$600 \leq \text{HLDL} < 650$	-3	-5	-9	-14
$650 \leq \text{HLDL} < 700$	-2	-5	-8	-13
$700 \leq \text{HLDL} < 750$	-2	-4	-7	-11

Table A.4 (continued)

Measured hardness HLDL	Correction HLDL			
	Impact direction $\theta = 45^\circ$	Impact direction $\theta = 90^\circ$	Impact direction $\theta = 135^\circ$	Impact direction $\theta = 180^\circ$
$750 \leq \text{HLDL} < 800$	-2	-3	-6	-10
$800 \leq \text{HLDL} < 850$	-1	-3	-5	-9
$850 \leq \text{HLDL} < 900$	-1	-2	-4	-7
$900 \leq \text{HLDL} < 950$	-1	-2	-3	-6

Table A.5 — Impact direction corrections, impact device type D+15

Measured hardness HLD+15	Correction HLD+15			
	Impact direction $\theta = 45^\circ$	Impact direction $\theta = 90^\circ$	Impact direction $\theta = 135^\circ$	Impact direction $\theta = 180^\circ$
$330 \leq \text{HLD}+15 < 350$	-7	-14	-26	-38
$350 \leq \text{HLD}+15 < 400$	-7	-13	-25	-36
$400 \leq \text{HLD}+15 < 450$	-6	-12	-23	-34
$450 \leq \text{HLD}+15 < 500$	-6	-12	-22	-32
$500 \leq \text{HLD}+15 < 550$	-6	-11	-21	-30
$550 \leq \text{HLD}+15 < 600$	-6	-11	-20	-28
$600 \leq \text{HLD}+15 < 650$	-5	-10	-19	-27
$650 \leq \text{HLD}+15 < 700$	-5	-10	-18	-25
$700 \leq \text{HLD}+15 < 750$	-5	-9	-17	-24
$750 \leq \text{HLD}+15 < 800$	-4	-9	-16	-22
$800 \leq \text{HLD}+15 < 850$	-4	-8	-15	-21
$850 \leq \text{HLD}+15 < 890$	-4	-8	-14	-20

Table A.6 — Impact direction corrections, impact device type C

Measured hardness HLC	Correction HLC			
	Impact direction $\theta = 45^\circ$	Impact direction $\theta = 90^\circ$	Impact direction $\theta = 135^\circ$	Impact direction $\theta = 180^\circ$
$350 \leq \text{HLC} < 400$	-7	-14	a	a
$400 \leq \text{HLC} < 450$	-7	-13		
$450 \leq \text{HLC} < 500$	-6	-13		
$500 \leq \text{HLC} < 550$	-6	-12		
$550 \leq \text{HLC} < 600$	-6	-11		
$600 \leq \text{HLC} < 650$	-5	-10		
$650 \leq \text{HLC} < 700$	-5	-10		
$700 \leq \text{HLC} < 750$	-4	-9		
$750 \leq \text{HLC} < 800$	-4	-8		
$800 \leq \text{HLC} < 850$	-4	-7		
$850 \leq \text{HLC} < 960$	-3	-6		

^a Not usually used at these angles, correction not known.

ISO 16859-1:2015(E)

Table A.7 — Impact direction corrections, impact device type G

Measured hardness HLG	Correction HLG			
	Impact direction $\theta = 45^\circ$	Impact direction $\theta = 90^\circ$	Impact direction $\theta = 135^\circ$	Impact direction $\theta = 180^\circ$
$300 \leq \text{HLG} < 350$	-2	-5	-12	-18
$350 \leq \text{HLG} < 400$	-2	-5	-11	-17
$400 \leq \text{HLG} < 450$	-2	-5	-11	-16
$450 \leq \text{HLG} < 500$	-2	-5	-10	-15
$500 \leq \text{HLG} < 550$	-2	-5	-9	-14
$550 \leq \text{HLG} < 600$	-2	-5	-9	-13
$600 \leq \text{HLG} < 650$	-2	-5	-8	-12
$650 \leq \text{HLG} < 700$	-2	-5	-8	-11
$700 \leq \text{HLG} < 750$	-2	-5	-7	-10

Annex B (normative)

Procedure for periodic checking of testing instrument by the user

The performance of each instrument should be verified prior to use on each day the instrument is used, in approximately each direction and at approximately each hardness level that is to be used.

Such periodic performance checking shall comprise at least three indentations on a reference test block calibrated in accordance with ISO 16859-3. The reference test block should be chosen to have its hardness close to the expected measured value, see [Table B.1](#). The reference test block shall be placed on a rigid support. The indentations should be uniformly distributed over the test surface. The instrument can be employed when it meets the following two requirements: the difference between the mean Leeb hardness and the calibration value on the reference test block shall be $\leq 5\%$ of the mean Leeb hardness, and the maximum span shall be $\leq 5\%$ of the mean Leeb hardness. Any instrument not meeting these requirements shall be subject to indirect verification.

Records of these tests should be retained to monitor the performance of the testing instrument over time.

Table B.1 — Typical Leeb hardness ranges of reference test blocks

Type of impact device	Leeb hardness range HL ^a
D, D+15	< 500 500 to 700 > 700
DL, S	< 700 700 to 850 > 850
C, E	< 600 600 to 750 > 750
G	< 450 450 to 600 > 600
^a HLD for impact devices D, HLD+15 for impact devices D+15, HLDL for impact devices DL, HLS for impact devices S, HLC for impact devices C, HLE for impact devices E, HLG for impact devices G.	

Annex C (informative)

Uncertainty of the measured Leeb hardness values

C.1 General requirements

The approach for determining uncertainty presented in this Annex considers only those uncertainties associated with the overall measurement performance of the Leeb hardness testing machine with respect to the reference test blocks, abbreviated as CRM (certified reference material) below. These performance uncertainties reflect the combined effect to all the separate uncertainties (indirect verification). Because of this approach, it is important that the individual machine components are operating within the tolerances. It is strongly recommended that this procedure should be applied for a maximum of one year after the successful passing of a direct verification.

Figure C.1 shows the four-level structure of the metrological chain necessary to define and disseminate hardness scales. The chain starts at the international level using international definitions of the various hardness scales to carry out international intercomparison tests. A number of *primary hardness standard machines* at the national level “produce” *primary reference test blocks* for the calibration laboratory level. These are used to “produce” reference test blocks at user level. Naturally, direct calibration and the verification of these machines should be at the highest possible accuracy.

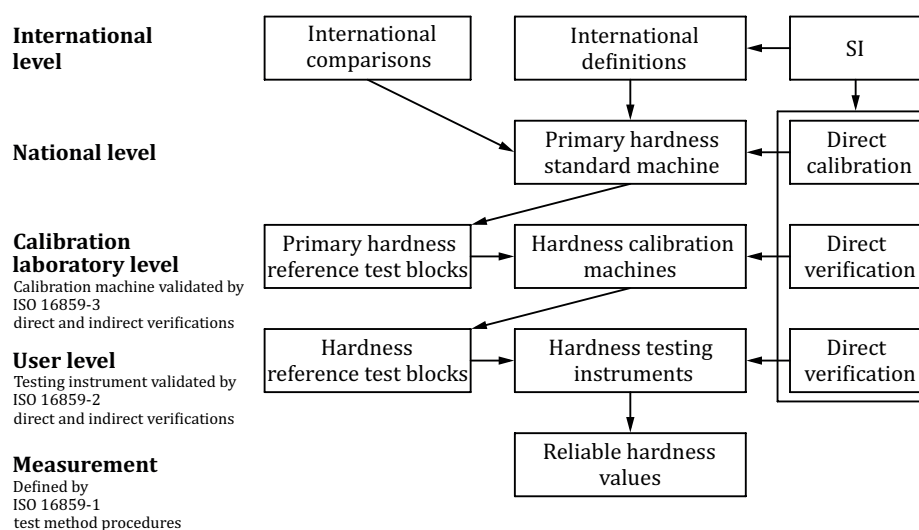

Figure C.1 — Structure of the metrological chain for the definition and dissemination of hardness scales

Measurement uncertainty analysis is a useful tool to help determine sources of error and to understand differences in test results. This Annex gives guidance on uncertainty estimation but the values derived are for information only, unless specifically instructed otherwise by the customer.

Most product specifications have tolerances that have been developed over the past years based mainly on the requirements of the product but also, in part, on the performance of the tester used to make the hardness measurement. These tolerances therefore incorporate a contribution due to the uncertainty of the hardness measurement and it would be inappropriate to make any further allowance for this uncertainty by, for example, reducing the specified tolerance by the estimated uncertainty of the hardness measurement. In other words, where a product specification states that the hardness of an

item shall be higher or lower than a certain value, this should be interpreted as simply specifying that the measured and calculated hardness value(s) shall meet this requirement, unless specifically stated otherwise in the product standard.

C.2 Procedures for calculating uncertainty of Leeb hardness measurement

C.2.1 General

This procedure calculates an expanded uncertainty U associated with the measured hardness value. Two different approaches, M1 and M2, to this calculation are given in [Tables C.1](#) and [C.2](#), together with details of the symbols used. In both cases, a number of uncorrelated standard uncertainty sources are combined by the Root-Sum-Square (RSS) method and then multiplied by the coverage factor $k = 2$.

NOTE This uncertainty approach makes no allowance for any possible drift in the tester performance subsequent to its last calibration, as it assumes that any such changes will be insignificant in magnitude. As such, most of this analysis could be performed immediately after the tester's calibration and the results included in the tester's calibration certificate.

C.2.2 Bias of the tester

The bias b of a hardness tester (also termed "error") is derived, during an indirect verification, from the difference between

- the certified calibration value of the hardness reference block, and
- the mean hardness value of the five indentations made in the hardness reference block during calibration of the hardness testing machine,

and can be implemented in different ways into the determination of uncertainty.

Two methods are given for determining the uncertainty of hardness measurements. Method M1 accounts for the systematic bias of the Leeb hardness testing instrument in two different ways. Method M2 allows the determination of uncertainty without having to consider the magnitude of the systematic bias.

Additional information on calculating hardness uncertainties can be found in the literature (see Reference [\[6\]](#)).

C.2.3 Method with consideration of bias (method M1)

The method M1 procedure for the determination of measurement uncertainty is explained in [Table C.1](#).

The measurement bias b of the Leeb hardness testing instrument can be expected to be a systematic effect. In GUM (see Reference [\[6\]](#)), it is recommended that a correction be used to compensate for systematic effects, and this is the basis of M1. The result of using this method is either all determined hardness values have to be reduced by b or the uncertainty U_{CORR} has to be increased by b . The procedure for the determination of U_{CORR} is explained in [Table C.1](#) (see References [\[11\]](#) and [\[12\]](#)).

ISO 16859-1:2015(E)

The expanded measurement uncertainty for a single hardness measurement is calculated as given in Formula (C.1):

$$U_{\text{corr}} = k \cdot \sqrt{u_{\text{CRM}}^2 + u_{\text{H}}^2 + u_{\text{ms}}^2} \quad (\text{C.1})$$

where

- u_{CRM} is a contribution to the measurement uncertainty due to the calibration uncertainty of the certified value of the CRM according to the calibration certificate for $k = 1$;
- u_{H} is a contribution to the measurement uncertainty due to the lack of measurement repeatability of the Leeb hardness testing instrument, calculated as the standard deviation of the hardness measurements when measuring the CRM;
- u_{ms} is a contribution to the measurement uncertainty due to the resolution of the Leeb hardness testing instrument.

The measurement result is given by Formula (C.2):

$$X_{\text{corr}} = (x - b) \pm U_{\text{corr}} \quad (\text{C.2})$$

or by Formula (C.3):

$$X_{\text{ucorr}} = x \pm (U_{\text{corr}} + |b|) \quad (\text{C.3})$$

depending on whether the bias b is considered to be part of the mean value or of the uncertainty.

When method M1 is used, it can also be appropriate to include additional uncertainty contributions within the Root-Sum-Square term relating to the value of b employed. This will particularly be the case when

- the measured hardness is significantly different from the hardness levels of the blocks used during the calibration of the instrument,
- the bias value of the instrument varies significantly throughout its calibrated range, or
- the material being measured is different from the material of the hardness reference test blocks used during the calibration of the instrument.

The calculations of these additional contributions to the measurement uncertainty are not discussed here. In all circumstances, a robust method for estimating the uncertainty associated with b is required.

C.2.4 Method without consideration of bias (method M2)

As an alternative to method M1, method M2 can be used in some circumstances. Method M2 is a simplified method which can be used without needing to consider the magnitude of any systematic bias of the Leeb hardness testing instrument; however, method M2 usually results in larger values of measurement uncertainty than method M1.

The procedure for the determination of U is explained in [Table C.2](#).

Method M2 is only valid for Leeb hardness testing instruments that have passed an indirect verification in accordance with ISO 16859-2 using the value $\Delta H_{\text{HTMmax}} = |b| + U_{\text{HTM}}$, rather than only the bias value b , when determining compliance with the maximum permissible error of the bias (see ISO 16859-2).

In method M2, the bias limit (the amount by which the machine's reading is allowed to differ from the reference test block's value, as specified in ISO 16859-2) is used to define one component U_{mpe} of the uncertainty. There is no correction of the hardness values with respect to the bias limit.

The combined expanded measurement uncertainty for a single future hardness measurement is calculated as shown in Formula (C.4):

$$U = k \times \sqrt{u_{\text{H}}^2 + u_{\text{ms}}^2 + \left(\frac{U_{\text{mpe}}}{\sqrt{3}}\right)^2} \quad (\text{C.4})$$

where

u_{H} is a contribution to the measurement uncertainty due to the lack of measurement repeatability of the Leeb hardness testing instrument;

u_{ms} is a contribution to the measurement uncertainty due to the resolution of the Leeb hardness testing instrument;

U_{mpe} is the maximum permissible error of the bias as specified in ISO 16859-2.

The measurement result is given by Formula (C.5):

$$X = x \pm U \quad (\text{C.5})$$

C.3 Presentation of measurement result

When reporting the measurement result, the method (M1 or M2) used to estimate the uncertainty should also be specified.

ISO 16859-1:2015(E)

Table C.1 — Determination of expanded uncertainty following method M1

Step	Source of uncertainty	Symbol	Formula	Literature/certificate	Example [.] = HLD
1	Standard uncertainty and mean Leeb hardness of CRM (for detailed calculation, refer to ISO 16859-3:2015, Table A.4)	$u_{\text{CRM}}, H_{\text{CRM}}$	$u_{\text{CRM}} = \frac{U_{\text{CRM}}}{2}$	$U_{\text{CRM}}, H_{\text{CRM}}$ according to calibration certificate of CRM. ^a	$u_{\text{CRM}} = \frac{5,52}{2} = 2,76$ $H_{\text{CRM}} = 767,0$
2	Mean value and standard deviation for measurement on CRM	\bar{H}, s_{H}	$\bar{H} = \frac{\sum_{i=1}^n H_i}{n};$ $s_{\text{H}} = \sqrt{\frac{1}{n-1} \sum_{i=1}^n (H_i - \bar{H})^2}$	H_i according to ISO 16859-2:2015, 5.3	Single readings: 764; 770; 768; 768; 765; 770; 766; 767; 772; 771 $\bar{H} = 768,1; s_{\text{H}} = 2,6$
3	Standard uncertainty of Leeb hardness tester for measurement on CRM	u_{H}	$u_{\text{H}} = t \times s_{\text{H}}$	$t = 1,06$ for $n = 10$ (see GUM, G.3 and Table G.2)	$u_{\text{H}} = 1,06 \times 2,6 = 2,76$
4	Standard uncertainty due to resolution of the Leeb hardness tester	u_{ms}	$u_{\text{ms}} = \frac{\text{ms}}{2\sqrt{3}}$	ms = 1 HLD	$u_{\text{ms}} = \frac{1}{2\sqrt{3}} = 0,29$
5	Bias of the Leeb hardness tester under the particular verification conditions	b	$b = \bar{H} - H_{\text{CRM}}$	b	$b = 768,1 - 767,0 = 1,1$
6	Determination of expanded uncertainty	U_{corr}	$U_{\text{corr}} = k \times \sqrt{u_{\text{CRM}}^2 + u_{\text{H}}^2 + u_{\text{ms}}^2}$	Steps 1, 3, 4 $k = 2$	$U = 2 \times \sqrt{2,76^2 + 2,76^2 + 0,29^2}$ $U = 7,8$
7	Measurement result with modified hardness for $x = 783,2$ HLD	X_{corr}	$X_{\text{corr}} = (x - b) \pm U_{\text{corr}}$	Steps 5 and 6	$X_{\text{corr}} = (782,1 \pm 7,8)$
8	Measurement result with modified uncertainty for $x = 783,2$ HLD	X_{ucorr}	$X_{\text{ucorr}} = x \pm (U_{\text{corr}} + b)$	Steps 5 and 6	$X_{\text{ucorr}} = (783,2 \pm 8,9)$
a	If $0,8 U_{\text{mpe}} < b < 1,0 U_{\text{mpe}}$, where U_{mpe} is as defined in Step 1 of Table C.2, the relationship of hardness values between CRM and sample should be considered.				
b	If necessary, the hardness change of the CRM has to be considered.				

Table C.2 — Determination of expanded uncertainty following method M2

Step	Source of uncertainty	Symbol	Formula	Literature/certificate	Example [.] = HLD
1	Expanded uncertainty derived from maximum permissible error	U_{mpe}	$U_{\text{mpe}} = E_{\text{rel}} \times H_{\text{CRM}}$	Permissible error E_{rel} according to ISO 16859-2:2015, Table 3. H_{CRM} from calibration certificate. ^a	$U_{\text{mpe}} = 0,02 \times 767 = 15,34$
2	Standard uncertainty and mean Leeb hardness of CRM (for detailed calculation, refer to ISO 16859-3:2015 Table A.4)	$u_{\text{CRM}},$ H_{CRM}	$u_{\text{CRM}} = \frac{U_{\text{CRM}}}{2}$	$U_{\text{CRM}}, H_{\text{CRM}}$ according to calibration certificate of CRM. ^a	$u_{\text{CRM}} = \frac{5,52}{2} = 2,76$ $H_{\text{CRM}} = 767,0$
3	Mean value and standard deviation for measurement on CRM	$\bar{H},$ s_{H}	$\bar{H} = \frac{\sum_{i=1}^n H_i}{n}$ $s_{\text{H}} = \sqrt{\frac{1}{n-1} \sum_{i=1}^n (H_i - \bar{H})^2}$	H_i according to ISO 16859-2:2015, 5.3	Single readings: 764; 770; 768; 768; 765; 770; 766; 767; 772; 771 $\bar{H} = 768,1 ; s_{\text{H}} = 2,6$
4	Standard uncertainty of Leeb hardness tester for measurement on CRM	u_{H}	$u_{\text{H}} = t \times s_{\text{H}}$	$t = 1,06$ for $n = 10$ (see GUM, G.3 and Table G.2)	$u_{\text{H}} = 1,06 \times 2,6 = 2,76$
5	Standard uncertainty due to resolution of the Leeb hardness tester	u_{ms}	$u_{\text{ms}} = \frac{\text{ms}}{2\sqrt{3}}$	$\text{ms} = 1$ HLD	$u_{\text{ms}} = \frac{1}{2\sqrt{3}} = 0,29$
6	Determination of expanded uncertainty	U	$U = k \times \sqrt{u_{\text{H}}^2 + u_{\text{ms}}^2 + \left(\frac{U_{\text{mpe}}}{\sqrt{3}}\right)^2}$	Steps 1, 2, 4, 5 $k = 2$	$U = 2 \times \sqrt{2,76^2 + 0,29^2 + 8,86^2}$ $U = 18,6$
7	Measurement result for $x = 783,2$ HLD	\bar{X}	$\bar{X} = x \pm U$	Step 6	$\bar{X} = (783,2 \pm 18,6)$
a	Where applicable, the change of Leeb hardness of the CRM needs to be accounted for.				

Annex D (informative)

Leeb hardness testing instruments

Commonly, an impact device consists of a load and release mechanism with induction coils on the one hand, and a freely moving impact body on the other hand (see [Figure D.1](#)).

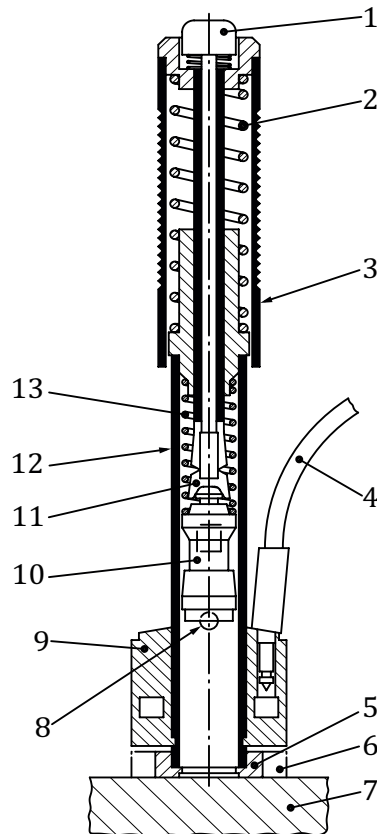

Key

1	trigger button	8	spherical indenter tip
2	loading spring	9	coil with coil housing
3	loading tube	10	impact body
4	signal cable between indicating unit and coil	11	catch chuck
5	small support ring	12	guide tube
6	large support ring	13	impact spring
7	test piece		

Figure D.1 — Schematic drawing of common impact device, shown before impact is triggered (impact spring under tension)

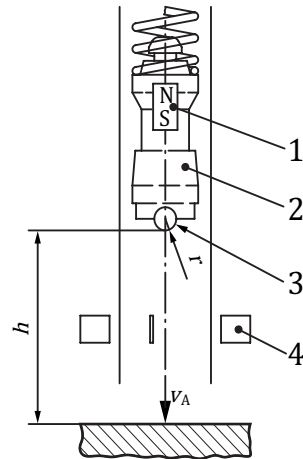
**Key**

- 1 permanent magnet (N-north pole, S-south pole)
- 2 impact body
- 3 indenter tip
- 4 induction coil

NOTE For the symbols, see [Table 1](#).

Figure D.2 — Schematic drawing of a typical impact body

Bibliography

- [1] LEEB D. *New dynamic method for hardness testing of metallic materials*, VDI-Report No. 308, pp. 123–128, 1978
- [2] BORGGREEN K., HANSEN D.H., HANSEN J.V., AUERKARI P. *Acceptance Values for Equotip Hardness of some Pressure Vessel Steels*, Nordtest Technical Report 424 — Part 1, FORCE Institute, Copenhagen, 1999
- [3] BORGGREEN K., TØNDER P., LORENTZEN M.S., HANSEN J.V., AUERKARI P. *Comparison of Portable Hardness Testers — Performance with Ideal Samples*, Nordtest Technical Report 424 — Part 2, FORCE Institute, Copenhagen, 1999
- [4] BORGGREEN K., TØNDER P., LORENTZEN M.S., HANSEN J.V., AUERKARI P. *Comparison of Portable Hardness Testers — Performance with Non-ideal Samples and Cases*, Nordtest Technical Report 424 — Part 3, FORCE Institute, Copenhagen, 1999
- [5] ISO 4287, *Geometrical Product Specifications (GPS) — Surface texture: Profile method — Terms, definitions and surface texture parameters*
- [6] ISO/IEC Guide 98-3:2008, *Uncertainty of measurement — Part 3: Guide to the expression of uncertainty in measurement (GUM:1995)*
- [7] DIN ISO 18265, *Metallic materials — Conversion of hardness values*
- [8] ASTM-International E140 – 10, *Standard Hardness Conversion Tables for Metals Relationship Among Brinell Hardness, Vickers Hardness, Rockwell Hardness, Superficial Hardness, Knoop Hardness, Scleroscope Hardness and Leeb Hardness*
- [9] YAMAMOTO T., YAMAMOTO M., TAKAGI S. *Current status of rebound hardness blocks in Japan and outlook*, Proceedings of IMEKO 2010: TC3, TC5 and TC22 Conferences, 379-382
- [10] ASTM-International A956 – 12, *Standard Test Method for Leeb Hardness Testing of Steel Products*
- [11] GABAUER W. *Manual codes of practice for the determination of uncertainties in mechanical tests on metallic materials, The estimation of uncertainties in hardness measurements*, Project No. SMT4-CT97-2165, UNCERT COP 14:2000
- [12] POLZIN T., & SCHWENK D. *Method for Uncertainty Determination of Hardness Testing; PC File for Determination*, Materialprüfung 44 (2002) 3, pp. 64–71

ISO 16859-1:2015(E)

ICS 77.040.10

Price based on 20 pages

© ISO 2015 – All rights reserved