



---

**P O L S K A N O R M A**

---

ICS 77.140.85; 77.040.20

**PN-EN 10228-2**

**Wprowadza**  
EN 10228-2:2016, IDT

**Zastępuje**  
PN-EN 10228-2:2000

## **Badania nieniszczące odkuwek stalowych**

### **Część 2: Badanie penetracyjne**

**Norma Europejska EN 10228-2:2016 *Non-destructive testing of steel forgings – Part 2: Penetrant testing* ma status Polskiej Normy**

© Copyright by PKN, Warszawa 2016

nr ref. PN-EN 10228-2:2016-07

---

**Wszelkie prawa autorskie zastrzeżone. Żadna część niniejszej publikacji nie może być zwielokrotniana jakkolwiek techniką bez pisemnej zgody Prezesa Polskiego Komitetu Normalizacyjnego**

---

ISBN 978-83-275-6378-1

## **PN-EN 10228-2:2016-07**

### **Przedmowa krajowa**

Niniejsza norma została zatwierdzona przez Prezesa PKN dnia 14 lipca 2016 r.

Komitetem krajowym odpowiedzialnym za normę jest KT nr 123 ds. Badań Własności Metali.

Istnieje możliwość przetłumaczenia normy na język polski na wniosek zainteresowanych środowisk. Decyzję podejmuje właściwy Komitet Techniczny.

Niniejsza norma zastępuje PN-EN 10228-2:2000.

Odpowiedniki krajowe norm i innych dokumentów powołanych w niniejszej normie można znaleźć w katalogu Polskich Norm. Oryginały norm i innych dokumentów powołanych są dostępne w PKN.

W sprawach merytorycznych dotyczących treści normy można zwracać się do właściwego Komitetu Technicznego lub właściwej Rady Sektorowej PKN, kontakt: [www.pkn.pl](http://www.pkn.pl).

### **Nota uznaniowa**

Norma Europejska EN 10228-2:2016 została uznana przez PKN za Polską Normę PN-EN 10228-2:2016-07.

EUROPEAN STANDARD

**EN 10228-2**

NORME EUROPÉENNE

EUROPÄISCHE NORM

June 2016

ICS 77.040.20; 77.140.85

Supersedes EN 10228-2:1998

English Version

## Non-destructive testing of steel forgings - Part 2: Penetrant testing

Essais non destructifs des pièces forgées en acier -  
Partie 2 : Contrôle par ressuage

Zerstörungsfreie Prüfung von Schmiedestücken aus  
Stahl - Teil 2: Eindringprüfung

This European Standard was approved by CEN on 3 October 2015.

CEN members are bound to comply with the CEN/CENELEC Internal Regulations which stipulate the conditions for giving this European Standard the status of a national standard without any alteration. Up-to-date lists and bibliographical references concerning such national standards may be obtained on application to the CEN-CENELEC Management Centre or to any CEN member.

This European Standard exists in three official versions (English, French, German). A version in any other language made by translation under the responsibility of a CEN member into its own language and notified to the CEN-CENELEC Management Centre has the same status as the official versions.

CEN members are the national standards bodies of Austria, Belgium, Bulgaria, Croatia, Cyprus, Czech Republic, Denmark, Estonia, Finland, Former Yugoslav Republic of Macedonia, France, Germany, Greece, Hungary, Iceland, Ireland, Italy, Latvia, Lithuania, Luxembourg, Malta, Netherlands, Norway, Poland, Portugal, Romania, Slovakia, Slovenia, Spain, Sweden, Switzerland, Turkey and United Kingdom.



EUROPEAN COMMITTEE FOR STANDARDIZATION  
COMITÉ EUROPÉEN DE NORMALISATION  
EUROPÄISCHES KOMITEE FÜR NORMUNG

**CEN-CENELEC Management Centre: Avenue Marnix 17, B-1000 Brussels**

<b>Contents</b>	<b>Page</b>
European foreword.....	3
<b>1 Scope</b> .....	<b>4</b>
<b>2 Normative references</b> .....	<b>4</b>
<b>3 Terms and definitions</b> .....	<b>4</b>
<b>4 Items for agreement</b> .....	<b>4</b>
<b>5 Test procedure</b> .....	<b>5</b>
5.1 General.....	5
5.2 Description.....	5
5.3 Content.....	5
<b>6 Personnel qualification</b> .....	<b>6</b>
<b>7 Testing system</b> .....	<b>6</b>
7.1 Testing products.....	6
7.2 Equipment.....	6
7.3 Function test.....	6
<b>8 Stage of manufacture</b> .....	<b>6</b>
<b>9 Surface condition</b> .....	<b>6</b>
<b>10 Coverage</b> .....	<b>7</b>
<b>11 Penetrant testing process</b> .....	<b>7</b>
<b>12 Viewing</b> .....	<b>7</b>
12.1 General.....	7
12.2 Viewing conditions.....	7
<b>13 Classification of indications</b> .....	<b>7</b>
<b>14 Recording and acceptance criteria</b> .....	<b>9</b>
<b>15 Removal of defects</b> .....	<b>10</b>
<b>16 Cleaning</b> .....	<b>10</b>
<b>17 Test report</b> .....	<b>11</b>
<b>Annex A (informative) Significant technical changes to the version EN 10228-2:1998</b> .....	<b>12</b>

## European foreword

This document (EN 10228-2:2016) has been prepared by Technical Committee ECISS/TC 111 “Steel castings and forgings”, the secretariat of which is held by AFNOR.

This European Standard shall be given the status of a national standard, either by publication of an identical text or by endorsement, at the latest by December 2016 and conflicting national standards shall be withdrawn at the latest by December 2016.

Attention is drawn to the possibility that some of the elements of this document may be the subject of patent rights. CEN [and/or CENELEC] shall not be held responsible for identifying any or all such patent rights.

This document supersedes EN 10228-2:1998.

Annex A provides the significant technical changes to the previous version EN 10228-2:1998.

EN 10228 consists of the following parts under the general title *Non-destructive testing of steel forgings*:

- *Part 1: Magnetic particle inspection;*
- *Part 2: Penetrant testing;*
- *Part 3: Ultrasonic testing of ferritic or martensitic steel forgings;*
- *Part 4: Ultrasonic testing of austenitic and austenitic-ferritic stainless steel forgings.*

According to the CEN-CENELEC Internal Regulations, the national standards organizations of the following countries are bound to implement this European Standard: Austria, Belgium, Bulgaria, Croatia, Cyprus, Czech Republic, Denmark, Estonia, Finland, Former Yugoslav Republic of Macedonia, France, Germany, Greece, Hungary, Iceland, Ireland, Italy, Latvia, Lithuania, Luxembourg, Malta, Netherlands, Norway, Poland, Portugal, Romania, Slovakia, Slovenia, Spain, Sweden, Switzerland, Turkey and the United Kingdom.

## EN 10228-2:2016 (E)

### 1 Scope

This European Standard describes techniques and acceptance criteria to be used for the penetrant testing of steel forgings. The method described is used for the detection of surface discontinuities.

### 2 Normative references

The following documents, in whole or in part, are normatively referenced in this document and are indispensable for its application. For dated references, only the edition cited applies. For undated references, the latest edition of the referenced document (including any amendments) applies.

EN ISO 3059, *Non-destructive testing — Penetrant testing and magnetic particle testing — Viewing conditions (ISO 3059)*

EN ISO 3452-1, *Non-destructive testing — Penetrant testing — Part 1: General principles (ISO 3452-1)*

EN ISO 3452-2, *Non-destructive testing — Penetrant testing — Part 2: Testing of penetrant materials (ISO 3452-2)*

EN ISO 3452-4, *Non-destructive testing — Penetrant testing — Part 4: Equipment (ISO 3452-4)*

EN ISO 9712, *Non-destructive testing — Qualification and certification of NDT personnel (ISO 9712)*

EN ISO 12706:2009, *Non-destructive testing — Penetrant testing — Vocabulary (ISO 12706:2009)*

### 3 Terms and definitions

For the purposes of this document, the terms and definitions given in EN ISO 12706:2009 apply.

### 4 Items for agreement

The following aspects concerning penetrant testing shall be agreed between the purchaser and the supplier at the time of enquiry and order:

- a) the manufacturing stage(s) at which penetrant testing shall be performed (see Clause 8);
- b) the areas to be examined;
- c) whether testing shall be performed with colour contrast or fluorescent penetrants (see 7.1);
- d) the quality class required, or the quality classes and surfaces areas to which they apply (see Clause 14);
- e) the applicable recording and acceptance criteria if different from those detailed in Table 2;
- f) whether the test shall be conducted in the presence of the purchaser or his representative;
- g) whether a written procedure shall be submitted for approval by the purchaser. (see Clause 5);

## 5 Test procedure

### 5.1 General

Penetrant testing shall be performed in accordance with a written test procedure. Where specified in the enquiry or order, the written procedure shall be submitted to the purchaser for approval prior to the test.

### 5.2 Description

The written procedure shall be one of the following:

- a) a product specification;
- b) a procedure written specifically for the application;
- c) this part of EN 10228 may be used if it is accompanied by testing details specific to the application.

### 5.3 Content

The written procedure shall contain the following details as minimum requirements:

- a) description of the forgings to be tested;
- b) reference documents;
- c) qualification of testing personnel;
- d) stage of manufacture at which the test is carried out;
- e) area(s) specified in terms of the applicable quality classes;
- f) type of penetrant testing products used: penetrant, remover, emulsifier, developer;
- g) surface conditions required;
- h) viewing conditions;
- i) description of pre-testing cleaning and drying, including cleaning materials used and minimum time allowed for drying;
- j) description of penetrant application, including application temperature and penetration time;
- k) description of excess penetrant removal and of drying before developer application;
- l) description of developer application, including development time;
- m) method of marking or recording indications;
- n) acceptance criteria;
- o) whether post-cleaning is required; if so, a description of the method;
- p) test report.

## EN 10228-2:2016 (E)

### 6 Personnel qualification

Personnel shall be qualified in accordance with EN ISO 9712.

### 7 Testing system

#### 7.1 Testing products

Penetrant testing products (penetrant, emulsifier, remover and developer) shall conform to EN ISO 3452-1. The combination of penetrant testing products to be used shall meet the following requirements:

- a) they shall conform to EN ISO 3452-1;
- b) they shall be compatible with the material to be tested (see EN ISO 3452-1 for guidance);
- c) they shall enable the applicable recording level (see Table 2) to be achieved (see EN ISO 3452-1 for the determination of sensitivity levels).

#### 7.2 Equipment

The equipment used shall conform to EN ISO 3452-4.

The following equipment may be used:

- a) spray gun or aerosol spray;
- b) immersion tank;
- c) electrostatic spray gun.

#### 7.3 Function test

The sensitivity of the penetrant shall be determined in accordance with EN ISO 3452-2.

The temperature of the forging should be checked to ensure that it is within the detection media manufacturer's specified temperature limits.

### 8 Stage of manufacture

Where practicable, final acceptance testing shall be performed on the forging in its delivery conditions (see Clause 4).

### 9 Surface condition

Surfaces to be tested shall be clean and free from scale, oil, grease, machining marks, paint and any other contaminant which could adversely affect test sensitivity or the ability to interpret indications.

The finish of surfaces to be tested shall conform to the requirements detailed in Table 1 for the applicable quality class.

Table 1 — Surface condition

Surface roughness parameter $R_a$ *), in $\mu\text{m}$	Quality classes <sup>a</sup>			
	1	2	3	4
$R_a \leq 12,5$	X	–	–	–
$R_a \leq 6,3$	X	X	X	X

<sup>a</sup> X signifies the quality class that can be achieved for the specified surface finish.  
<sup>\*)</sup>  $R_a$  = arithmetical mean deviation of the profile.

## 10 Coverage

Where practicable, the test shall be performed in such a way that 100 % coverage of the surface to be tested is achieved.

## 11 Penetrant testing process

The penetrant testing process shall conform to EN ISO 3452-1.

## 12 Viewing

### 12.1 General

Viewing shall start immediately after the developer is applied and shall continue periodically up to the completion of the development time, when final assessment of indications shall be made.

### 12.2 Viewing conditions

Viewing conditions shall be in accordance with EN ISO 3059:

#### a) Colour contrast penetrants:

The surface under testing shall be viewed under white light of at least 500 lx intensity on the surface. Glare and reflections shall be avoided.

Lower illuminances may be agreed between purchaser and supplier.

#### b) Fluorescent penetrants:

Prior to the test at least 5 min shall be allowed for the operator's eyes to become adapted to the reduced background lighting and the UV-A lamp shall be allowed to warm up for at least 5 min.

## 13 Classification of indications

The following rules shall apply (see Figure 1):

- a) A linear indication shall be considered “isolated” when it is not aligned with any other linear indication, or when it is aligned with another linear indication, but separated from it by more than five times the length of the longer of the two indications considered.

**EN 10228-2:2016 (E)**

- b) Interacting linear indications are two (or more) linear indications which are aligned, and shall be considered as one continuous length for the purpose of assessment if their separation is less than, or equal to, five times the length of the longer of the two indications considered. The length of interacting indications is the length measured between the opposite ends of the two outer indications.
- c) The cumulative length of linear indications is the sum of the lengths of all linear indications detected in the reference surface (i.e. 148 mm × 105 mm, or = A6 format).

NOTE A linear indication is an indication the length of which is greater than three times the width.

- d) A rounded indication is an indication the length of which is less than or equal to three times the width.
- e) False indications due to the geometry of the part (change of section or slot, etc.) or surface finish (scar or machining mark, etc.) shall not be taken into account.

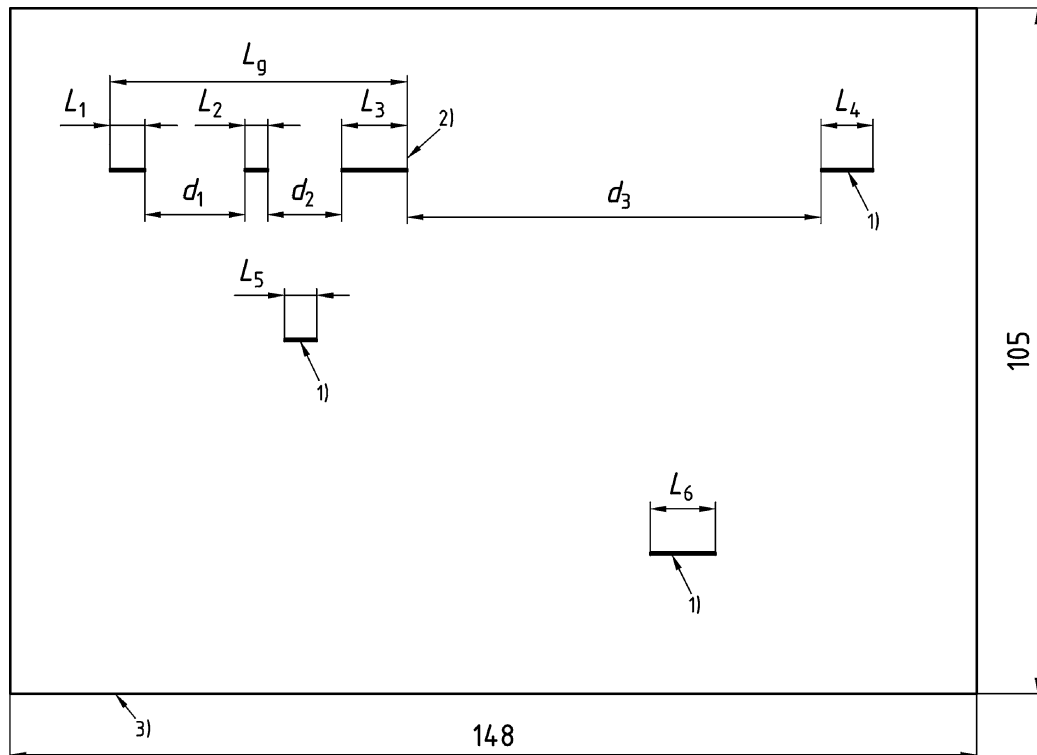

### Key

- 1 isolated indications
- 2 interacting indications
- 3 reference surface

Reference surface = 148 mm × 105 mm (i.e. A6 format).

$d_1 = 15,2$  mm,  $d_2 = 11,6$  mm,  $d_3 = 63,5$  mm,  $L_1 = 5,8$  mm,  $L_2 = 3,6$  mm,  $L_3 = 10,1$  mm,  $L_4 = 7,9$  mm,  $L_5 = 5,1$  mm,  $L_6 = 10,1$  mm

$d_1 < 5L_1$ ;  $d_2 < 5L_3$ ;  $d_3 > 5L_3$ .

$L_1$ ,  $L_2$  and  $L_3$  = Individual lengths of interacting indications.

$L_g$  = Total length of interacting indications

$L_g = (L_1 + d_1) + (L_2 + d_2) + L_3$ .

$L_4$ ,  $L_5$  and  $L_6$  = lengths of isolated indications.

$L_g + L_4 + L_5 + L_6$  = cumulative length of indications in reference surface.

The total number of indications in the reference surface is 4 (as identified by  $L_g$ ,  $L_4$ ,  $L_5$  and  $L_6$ ), see Table 2.

**Figure 1 — Classification of linear indications**

## 14 Recording and acceptance criteria

Four quality classes shall be applied to a forging or to parts of a forging. Quality class 4 is the most stringent, dictating the smallest recording level and the smallest acceptance standard. For forgings for general application supplied in the as-forged surface condition only, quality classes 1 and 2 are applicable. For closed die forgings, quality class 3 shall be the minimum requirement.

**EN 10228-2:2016 (E)**

The applicable quality class(-es) shall be agreed between the purchaser and the supplier. Table 2 details recording levels and acceptance criteria to be applied for four quality classes.

Where agreed, recording levels and acceptance criteria different from those detailed in Table 2 may be used.

**Table 2 — Quality classes, recording levels and acceptance criteria**

Parameter	Quality class			
	1	2	3	4 <sup>a</sup>
Recording level (mm) <sup>b</sup>	≥ 7	≥ 3	≥ 3	≥ 1
Allowable length $L$ of isolated linear indications and allowable length $L_g$ of interacting indications (mm) <sup>b</sup>	≤ 20	≤ 8	≤ 4	≤ 2
Allowable cumulative length of linear indications in the reference surface (mm) <sup>b</sup>	≤ 75	≤ 36	≤ 24	≤ 5
Allowable size of isolated rounded indications (mm) <sup>b</sup>	≤ 30	≤ 12	≤ 8	≤ 3
Maximum allowable number of recordable indications on reference surface <sup>c</sup>	15	10	7	5
<sup>a</sup> Quality class 4 is not applicable to the test of areas with machining allowance ≥ 0,5 mm per face. <sup>b</sup> The tabulated values apply to the indication size, not to the surface extent of the flaw. <sup>c</sup> Reference surface = 148 mm × 105 mm (i.e. A6 format) For objects smaller than the reference surface, or if only an area is examined smaller than the reference surface, then the maximum allowable number of indications should be determined and agreed accordingly (the acceptance criteria for the dimensions remain unchanged)..				

## 15 Removal of defects

Indications which do not meet the applicable acceptance criteria shall be considered as defects. Removal of a defect shall be followed by further penetrant testing, using the same penetrant testing system as the first test. Provided that the forging dimensions remain in tolerance, defects shall be eliminated by grinding and/or machining. Elimination of a defect by grinding shall be carried out in the direction perpendicular to the defect and in such a manner as to blend the resulting hollow with the remaining surface.

## 16 Cleaning

Cleaning shall be carried out after penetrant testing when penetrant testing products could interfere with subsequent processing or service requirements.

## 17 Test report

All penetrant tests shall be the subject of a written report which shall include the following information as minimum requirements:

- a) name of supplier;
- b) order number;
- c) identification of forging(s) under test;
- d) scope of testing: surface(s) and applicable quality class(es);
- e) stage of manufacture at which penetrant testing was performed;
- f) surface condition;
- g) designation of penetrant system used in accordance with EN ISO 3452-1, together with the make and designations of products used including the batch number;
- h) viewing conditions;
- i) reference to this standard or to the written procedure used (where applicable);
- j) results of the test:
  - 1) location;
  - 2) classification;
  - 3) orientation and size of all indications exceeding the appropriate recording level;
  - 4) number of recorded indications in reference surface;
  - 5) description of unacceptable indications;
- k) details of any restrictions to the required coverage;
- l) date of the test;
- m) name, qualification, certification (if specified) and signature of the operator.

**EN 10228-2:2016 (E)**

**Annex A**  
(informative)

**Significant technical changes to the version EN 10228-2:1998**

Some significant technical changes to the previous version EN 10228-2:1998 are listed below:

- a) updating of the normative references;
- b) generally updating and alignment of the designations to the actual state of art;
- c) Figure 1 and the correspondent explanations updated.