



P O L S K A N O R M A

ICS 25.160.40

PN-EN ISO 17636-1

Wprowadza
EN ISO 17636-1:2013, IDT
ISO 17636-1:2013, IDT

Zastępuje
PN-EN 1435:2001

Badania nieniszczące spoin

Badanie radiograficzne

**Część 1: Techniki promieniowania X i gamma
z błoną**

Norma Europejska EN ISO 17636-1:2013 *Non-destructive testing of welds – Radiographic testing – Part 1: X- and gamma-ray techniques with film (ISO 17636-1:2013)* ma status Polskiej Normy

© Copyright by PKN, Warszawa 2013

nr ref. PN-EN ISO 17636-1:2013-06

Wszelkie prawa autorskie zastrzeżone. Żadna część niniejszej publikacji nie może być zwielokrotniana jakkolwiek techniką bez pisemnej zgody Prezesa Polskiego Komitetu Normalizacyjnego

ISBN 978-83-275-1180-5

PN-EN ISO 17636-1:2013-06

Przedmowa krajowa

Niniejsza norma została zatwierdzona przez Prezesa PKN dnia 10 czerwca 2013 r.

Komitetem krajowym odpowiedzialnym za normę jest KT nr 165 ds. Spawania i Procesów Pokrewnych.

Istnieje możliwość przetłumaczenia normy na język polski na wniosek zainteresowanych środowisk. Decyzję podejmuje właściwy Komitet Techniczny.

Niniejsza norma zastępuje PN-EN 1435:2001.

Odpowiedniki krajowe norm i innych dokumentów powołanych w niniejszej normie można znaleźć w katalogu Polskich Norm. Oryginały norm i innych dokumentów powołanych są dostępne w PKN.

W sprawach merytorycznych dotyczących treści normy można zwracać się do właściwego Komitetu Technicznego lub właściwej Rady Sektorowej PKN, kontakt: www.pkn.pl

Nota uznaniowa

Norma Europejska EN ISO 17636-1:2013 została uznana przez PKN za Polską Normę PN-EN ISO 17636-1:2013-06.

EUROPEAN STANDARD

EN ISO 17636-1

NORME EUROPÉENNE

EUROPÄISCHE NORM

January 2013

ICS 25.160.40

Supersedes EN 1435:1997

English Version

**Non-destructive testing of welds - Radiographic testing - Part 1:
X- and gamma-ray techniques with film (ISO 17636-1:2013)**

Contrôle non destructif des assemblages soudés - Contrôle
par radiographie - Partie 1: Techniques par rayons X ou
gamma à l'aide de film (ISO 17636-1:2013)

Zerstörungsfreie Prüfung von Schweißverbindungen -
Durchstrahlungsprüfung - Teil 1: Röntgen- und
Gammastrahlungstechniken mit Filmen (ISO 17636-
1:2013)

This European Standard was approved by CEN on 14 December 2012.

CEN members are bound to comply with the CEN/CENELEC Internal Regulations which stipulate the conditions for giving this European Standard the status of a national standard without any alteration. Up-to-date lists and bibliographical references concerning such national standards may be obtained on application to the CEN-CENELEC Management Centre or to any CEN member.

This European Standard exists in three official versions (English, French, German). A version in any other language made by translation under the responsibility of a CEN member into its own language and notified to the CEN-CENELEC Management Centre has the same status as the official versions.

CEN members are the national standards bodies of Austria, Belgium, Bulgaria, Croatia, Cyprus, Czech Republic, Denmark, Estonia, Finland, Former Yugoslav Republic of Macedonia, France, Germany, Greece, Hungary, Iceland, Ireland, Italy, Latvia, Lithuania, Luxembourg, Malta, Netherlands, Norway, Poland, Portugal, Romania, Slovakia, Slovenia, Spain, Sweden, Switzerland, Turkey and United Kingdom.



EUROPEAN COMMITTEE FOR STANDARDIZATION
COMITÉ EUROPÉEN DE NORMALISATION
EUROPÄISCHES KOMITEE FÜR NORMUNG

Management Centre: Avenue Marnix 17, B-1000 Brussels

EN ISO 17636-1:2013 (E)

Contents

Page

Foreword.....3

Foreword

This document (EN ISO 17636-1:2013) has been prepared by Technical Committee CEN/TC 121 "Welding" the secretariat of which is held by DIN, in collaboration with Technical Committee ISO/TC 44 "Welding and allied processes".

This European Standard shall be given the status of a national standard, either by publication of an identical text or by endorsement, at the latest by July 2013, and conflicting national standards shall be withdrawn at the latest by July 2013.

Attention is drawn to the possibility that some of the elements of this document may be the subject of patent rights. CEN [and/or CENELEC] shall not be held responsible for identifying any or all such patent rights.

This document supersedes EN 1435:1997.

According to the CEN/CENELEC Internal Regulations, the national standards organisations of the following countries are bound to implement this European Standard: Austria, Belgium, Bulgaria, Croatia, Cyprus, Czech Republic, Denmark, Estonia, Finland, Former Yugoslav Republic of Macedonia, France, Germany, Greece, Hungary, Iceland, Ireland, Italy, Latvia, Lithuania, Luxembourg, Malta, Netherlands, Norway, Poland, Portugal, Romania, Slovakia, Slovenia, Spain, Sweden, Switzerland, Turkey and the United Kingdom.

INTERNATIONAL STANDARD

ISO 17636-1

First edition
2013-01-15

Non-destructive testing of welds — Radiographic testing —

Part 1: X- and gamma-ray techniques with film

*Contrôle non destructif des assemblages soudés — Contrôle par
radiographie —*

Partie 1: Techniques par rayons X ou gamma à l'aide de film



Reference number
ISO 17636-1:2013(E)

© ISO 2013

ISO 17636-1:2013(E)



COPYRIGHT PROTECTED DOCUMENT

© ISO 2013

All rights reserved. Unless otherwise specified, no part of this publication may be reproduced or utilized in any form or by any means, electronic or mechanical, including photocopying and microfilm, without permission in writing from either ISO at the address below or ISO's member body in the country of the requester.

ISO copyright office
Case postale 56 • CH-1211 Geneva 20
Tel. + 41 22 749 01 11
Fax + 41 22 749 09 47
E-mail copyright@iso.org
Web www.iso.org

Published in Switzerland

Contents

Page

Foreword	iv
Introduction.....	v
1 Scope	1
2 Normative references	1
3 Terms and definitions	2
4 Symbols and abbreviated terms	3
5 Classification of radiographic techniques.....	3
6 General preparations and requirements	4
6.1 Protection against ionizing radiation	4
6.2 Surface preparation and stage of manufacture	4
6.3 Location of the weld in the radiograph	4
6.4 Identification of radiographs	4
6.5 Marking	4
6.6 Overlap of films	4
6.7 Types and positions of image quality indicators.....	4
6.8 Evaluation of image quality	5
6.9 Minimum image quality values	5
6.10 Personnel qualification	6
7 Recommended techniques for making radiographs	6
7.1 Test arrangements	6
7.2 Choice of tube voltage and radiation source	12
7.3 Film systems and metal screens	13
7.4 Alignment of beam	15
7.5 Reduction of scattered radiation	15
7.6 Source-to-object distance	15
7.7 Maximum area for a single exposure	18
7.8 Density of radiograph	18
7.9 Processing	18
7.10 Film viewing conditions.....	19
8 Test report.....	19
Annex A (normative) Recommended number of exposures which give an acceptable examination of a circumferential butt weld	21
Annex B (normative) Minimum image quality values	26
Bibliography.....	30

ISO 17636-1:2013(E)

Foreword

ISO (the International Organization for Standardization) is a worldwide federation of national standards bodies (ISO member bodies). The work of preparing International Standards is normally carried out through ISO technical committees. Each member body interested in a subject for which a technical committee has been established has the right to be represented on that committee. International organizations, governmental and non-governmental, in liaison with ISO, also take part in the work. ISO collaborates closely with the International Electrotechnical Commission (IEC) on all matters of electrotechnical standardization.

International Standards are drafted in accordance with the rules given in the ISO/IEC Directives, Part 2.

The main task of technical committees is to prepare International Standards. Draft International Standards adopted by the technical committees are circulated to the member bodies for voting. Publication as an International Standard requires approval by at least 75 % of the member bodies casting a vote.

Attention is drawn to the possibility that some of the elements of this document may be the subject of patent rights. ISO shall not be held responsible for identifying any or all such patent rights.

ISO 17636-1 was prepared by the European Committee for Standardization (CEN) in collaboration with ISO Technical Committee TC 44, *Welding and allied processes*, Subcommittee SC 5, *Testing and inspection of welds* in accordance with the Agreement on technical cooperation between ISO and CEN (Vienna Agreement).

This first edition, together with ISO 17636-2, cancels and replaces ISO 17636:2003, of which it constitutes a technical revision.

ISO 17636 consists of the following parts, under the general title *Non-destructive testing of welds — Radiographic testing*:

- *Part 1: X- and gamma-ray techniques with film*
- *Part 2: X- and gamma-ray techniques with digital detectors*

The main changes are that:

- the normative references have been updated;
- the document has been divided into two parts — this part of ISO 17636 applies to radiographic testing with films;
- X-ray devices up to 1 000 kV have been included;
- the text has been editorially revised.

Requests for official interpretations of any aspect of this part of ISO 17636 should be directed to the Secretariat of ISO/TC 44/SC 5 via your national standards body. A complete listing of these bodies can be found at www.iso.org.

Introduction

This International Standard specifies fundamental techniques of radiography with the object of enabling satisfactory and repeatable results to be obtained economically. The techniques are based on generally recognized practice and fundamental theory of the subject, inspection of fusion welded joints with industrial radiographic films.

Non-destructive testing of welds — Radiographic testing —

Part 1: X- and gamma-ray techniques with film

1 Scope

This part of ISO 17636 specifies techniques of radiographic examination of fusion welded joints in metallic materials using industrial radiographic film techniques.

This part of ISO 17636 applies to the joints of plates and pipes. Besides its conventional meaning, “pipe” as used in this International Standard covers other cylindrical bodies such as tubes, penstocks, boiler drums, and pressure vessels.

NOTE This part of ISO 17636 complies with ISO 5579.^[1]

This part of ISO 17636 does not specify acceptance levels for any of the indications found on the radiographs.

If contracting parties apply lower test criteria, it is possible that the quality achieved is significantly lower than when this part of ISO 17636 is strictly applied.

2 Normative references

The following referenced documents are indispensable for the application of this document. For dated references, only the edition cited applies. For undated references, the latest edition of the referenced document (including any amendments) applies.

ISO 5576, *Non-destructive testing — Industrial X-ray and gamma-ray radiology — Vocabulary*

ISO 5580, *Non-destructive testing — Industrial radiographic illuminators — Minimum requirements*

ISO 9712, *Non-destructive testing — Qualification and certification of NDT personnel*

ISO 11699-1, *Non-destructive testing — Industrial radiographic film — Part 1: Classification of film systems for industrial radiography*

ISO 11699-2, *Non-destructive testing — Industrial radiographic films — Part 2: Control of film processing by means of reference values*

ISO 19232-1, *Non-destructive testing — Image quality of radiographs — Part 1: Image quality indicators (wire type) — Determination of image quality value*

ISO 19232-2, *Non-destructive testing — Image quality of radiographs — Part 2: Image quality indicators (step/hole type) — Determination of image quality value*

ISO 19232-4, *Non-destructive testing — Image quality of radiographs — Part 4: Experimental evaluation of image quality values and image quality tables*

ISO 17636-1:2013(E)

EN 12543 (all parts), *Non-destructive testing — Characteristics of focal spots in industrial X-ray systems for use in non-destructive testing*

EN 12679, *Non-destructive testing — Determination of the size of industrial radiographic sources — Radiographic method*

3 Terms and definitions

For the purposes of this document, the terms and definitions given in ISO 5576 and the following apply.

3.1 nominal thickness

t

nominal thickness of the parent material only where manufacturing tolerances do not have to be taken into account

3.2 penetration thickness change

Δt

change of penetrated thickness relative to the nominal thickness due to beam angle

3.3 penetrated thickness

w

thickness of material in the direction of the radiation beam calculated on the basis of the nominal thicknesses of all penetrated walls

3.4 object-to-film distance

b

distance between the radiation side of the radiographed part of the test object and the film surface measured along the central axis of the radiation beam

3.5 source size

d

size of the radiation source or focal spot size

NOTE See EN 12679 or EN 12543.

3.6 source-to-film distance

SFD

SDD

distance between the source of radiation and the film measured in the direction of the beam

NOTE $SFD = f + b$

where

f source-to-object distance

b object-to-film distance

3.7 source-to-object distance

f

distance between the source of radiation and the source side of the test object measured along the central axis of the radiation beam

3.8**external diameter** D_e

nominal external diameter of the pipe

4 Symbols and abbreviated terms

For the purposes of this document, the symbols given in Table 1 apply.

Table 1 — Symbols and terms

Symbol	Term
b	object-to-film distance
b'	object-to-film distance perpendicular to test object
D_e	external diameter
d	source size
f	source-to-object distance
f'	source-to-object distance perpendicular to test object
f_{\min}	minimum source-to-object distance
t	nominal thickness
Δt	penetration thickness change
w	penetrated thickness
F	film
IQI	image quality indicator
S	radiation source
SFD	source-to-film distance
SDD	

5 Classification of radiographic techniques

The radiographic techniques are divided into two classes:

- Class A: basic techniques;
- Class B: improved techniques.

Class B techniques are used when class A might be insufficiently sensitive.

Better techniques compared to class B are possible and may be agreed between the contracting parties by specification of all appropriate test parameters.

The choice of radiographic technique shall be agreed between the contracting parties.

If, for technical or industrial reasons, it is not possible to meet one of the conditions specified for class B, such as the type of radiation source or the source-to-object distance, f , it may be agreed by contracting parties that the condition selected may be that specified for class A. The loss of sensitivity shall be compensated by an increase of minimum density to 3,0 or by selection of a better film system class with a minimum density of 2,6. The other conditions for class B remain unchanged, especially the image quality achieved (see Tables B.1 to

ISO 17636-1:2013(E)

B.12). Because of the better sensitivity compared to class A, the test specimen may be regarded as being examined to class B. This does not apply if the special SFD reductions as described in 7.6 for test arrangements 7.1.4 and 7.1.5 are used.

6 General preparations and requirements

6.1 Protection against ionizing radiation

WARNING — Exposure of any part of the human body to X-rays or gamma-rays can be highly injurious to health. Wherever X-ray equipment or radioactive sources are in use, appropriate legal requirements shall be applied.

Local or national or international safety precautions when using ionizing radiation shall be strictly applied.

6.2 Surface preparation and stage of manufacture

In general, surface preparation is not necessary, but where surface imperfections or coatings can cause difficulty in detecting defects, the surface shall be ground smooth or the coatings shall be removed.

Unless otherwise specified, radiography shall be carried out after the final stage of manufacture, e.g. after grinding or heat treatment.

6.3 Location of the weld in the radiograph

Where the radiograph does not show the weld, high density markers shall be placed on either side of the weld.

6.4 Identification of radiographs

Symbols shall be affixed to each section of the object being radiographed. The images of these symbols shall appear in the radiograph outside the region of interest where possible and shall ensure unambiguous identification of the section.

6.5 Marking

Permanent markings on the object to be examined shall be made in order to accurately locate the position of each radiograph (e.g. zero point, direction, identification, measure).

Where the nature of the material and/or its service conditions do not permit permanent marking, the location may be recorded by means of accurate sketches or photographs.

6.6 Overlap of films

When radiographing an area with two or more separate films, the films shall overlap sufficiently to ensure that the complete region of interest is radiographed. This shall be verified by a high density marker on the surface of the object which is to appear on each film.

6.7 Types and positions of image quality indicators

The quality of image shall be verified by use of image quality indicators (IQIs) in accordance with ISO 19232-1 or ISO 19232-2.

The IQI used shall be placed preferably on the source side of the test object at the centre of the area of interest on the parent metal beside the weld. The identification numbers and, when used, the lead letter F, shall not be in the area of interest, except when geometric configuration makes it impractical. The IQI shall be in close contact with the surface of the object.

Its location shall be made in a section of uniform thickness characterized by a uniform optical density on the film.

According to the IQI type used, cases a) and b) shall be considered.

- a) When using a wire IQI, the wires shall be directed perpendicular to the weld and its location shall ensure that at least 10 mm of the wire length shows in a section of uniform optical density, which is normally in the parent metal adjacent to the weld. For exposures in accordance with 7.1.6 and 7.1.7, the IQI can be placed with the wires across the pipe axis and they should not be projected into the image of the weld.
- b) When using a step hole IQI, it shall be placed in such way that the hole number required is placed close to the weld.

For exposures in accordance with 7.1.6 and 7.1.7, the IQI type used can be placed either on the source or on the film side. If the IQIs cannot be placed in accordance with the above conditions, the IQIs are placed on the film side and the image quality shall be determined at least once from comparison exposure with one IQI placed at the source side and one at the film side under the same conditions.

For double wall exposures, when the IQI is placed on the film side, the above test is not necessary. In this case, refer to the correspondence tables (Tables B.3 to B.12).

Where the IQIs are placed on the film side, the letter F shall be placed near the IQI and it shall be stated in the test report.

If steps have been taken to guarantee that radiographs of similar test objects and regions are produced with identical exposure and processing techniques, and no differences in the image quality value are likely, the image quality need not be verified for every radiograph. The extent of image quality verification should be subject to agreement between the contracting parties.

For exposures of pipes with diameter 200 mm and above with the source centrally located at least three IQIs should be placed equally spaced at the circumference. The film(s) showing IQI images are then considered representative for the whole circumference.

6.8 Evaluation of image quality

The films shall be viewed in accordance with ISO 5580.

From the examination of the image of the IQI on the radiograph, the number of the smallest wire or hole which can be discerned is determined. The image of a wire is accepted if a continuous length of at least 10 mm is clearly visible in a section of uniform optical density. In the case of the step hole type IQI, if there are two holes of the same diameter, both shall be discernible, in order that the step be considered as visible.

The IQI value obtained shall be indicated on the test report of the radiographic examination. In each case the type of indicator used shall be clearly stated, as shown on the IQI.

6.9 Minimum image quality values

Tables B.1 to B.12 show the minimum quality values for metallic materials. For other materials these requirements or corresponding requirements may be agreed upon by contracting parties. The requirements shall be determined in accordance with ISO 19232-4.

In the case where Ir 192 or Se 75 sources are used, IQI values worse than the ones listed in Tables B.1 to B.12 may be accepted by agreement of contracting parties as follows:

ISO 17636-1:2013(E)

Double wall, double image techniques, both class A and B ($w = 2t$):

— $10 \text{ mm} < w \leq 25 \text{ mm}$: 1 wire or step hole value less for Ir 192;

— $5 \text{ mm} < w \leq 12 \text{ mm}$: 1 wire or step hole value less for Se 75.

Single wall single image and double wall single image techniques, class A:

— $10 \text{ mm} < w \leq 24 \text{ mm}$: 2 wire or step hole values less for Ir 192;

— $24 \text{ mm} < w \leq 30 \text{ mm}$: 1 wire or step hole value less for Ir 192;

— $5 \text{ mm} < w \leq 24 \text{ mm}$: 1 wire or step hole value less for Se 75.

Single wall single image and double wall single image techniques, class B:

— $10 \text{ mm} < w \leq 40 \text{ mm}$: 1 wire or step hole value less for Ir 192;

— $5 \text{ mm} < w \leq 20 \text{ mm}$: 1 wire or step hole value less for Se 75.

6.10 Personnel qualification

Personnel performing non-destructive examination in accordance with this part of ISO 17636 shall be qualified in accordance with ISO 9712 or equivalent to an appropriate level in the relevant industrial sector.

7 Recommended techniques for making radiographs

NOTE Unless otherwise explained, definitions of the symbols used in Figures 1 to 21 can be found in Clause 4.

7.1 Test arrangements**7.1.1 General**

Normally radiographic techniques in accordance with 7.1.2 to 7.1.9 shall be used.

X-ray film shall be placed as close to the object as possible.

The elliptical technique (double wall and double image) in accordance with Figure 11 should not be used for external diameter $D_e > 100 \text{ mm}$ or wall thickness $t > 8 \text{ mm}$ or weld width $> D_e/4$. Two 90° displaced images are sufficient if $t/D_e < 0,12$; otherwise three images are needed. The distance between the two projected weld images shall be about one weld width.

When it is difficult to carry out an elliptical examination at $D_e \leq 100 \text{ mm}$, the perpendicular technique in accordance with 7.1.7 may be used (see Figure 12). In this case, three exposures 120° or 60° apart are required.

For test arrangements in accordance with Figures 11, 13, and 14, the inclination of the beam shall be kept as small as possible and be such as to prevent superimposition of the two images. The source-to-object distance, f_s , shall be kept as small as possible for the technique shown in Figure 13, in accordance with 7.6. The IQI shall be placed close to the film with a lead letter F.

Other radiographic techniques may be agreed by the contracting parties when it is useful, e.g. for reasons such as the geometry of the piece or differences in material thickness. In 7.1.9 an example of such a case is presented. Multi-film techniques shall not be used to reduce exposure times on uniform sections. Additionally, thickness compensation with the same material may be applied.

NOTE In Annex A, the minimum number of radiographs necessary is given in order to obtain an acceptable radiographic coverage of the total circumference of a butt weld in pipe.

7.1.2 Radiation source located in front of the object and with the film at the opposite side (see Figure 1)

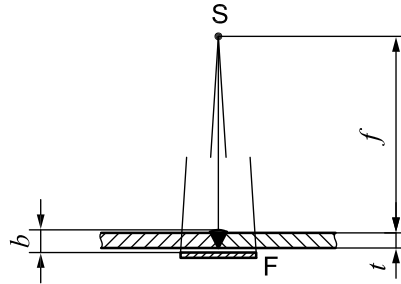

Figure 1 — Test arrangement for plane welds and single wall penetration

7.1.3 Radiation source located outside the object and film inside (see Figures 2 to 4)

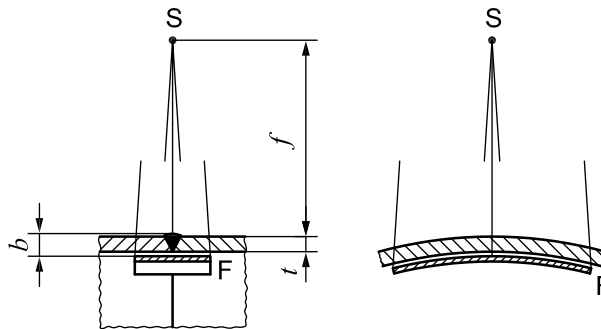

Figure 2 — Test arrangement for single wall penetration of curved objects

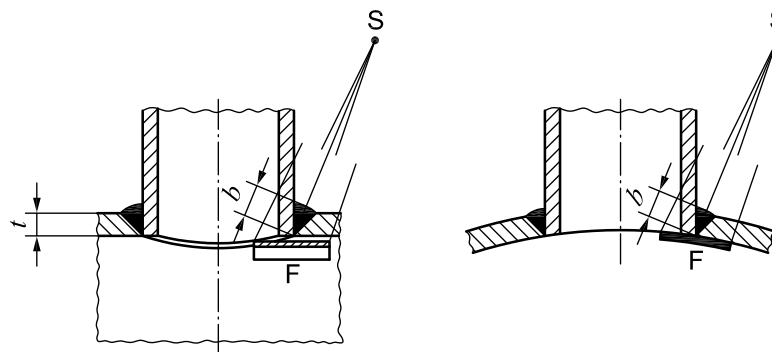

Figure 3 — Test arrangement for single wall penetration of curved objects (set-in weld)

ISO 17636-1:2013(E)

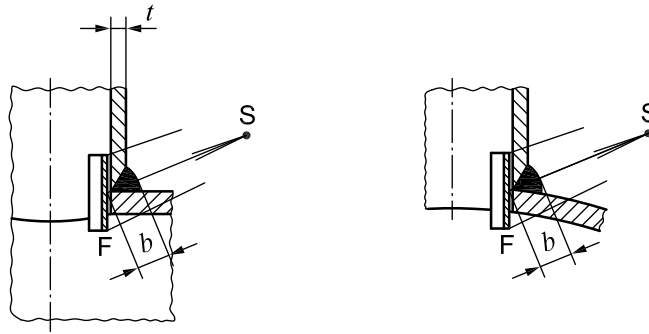

Figure 4 — Test arrangement for single wall penetration of curved objects (set-on weld)

7.1.4 Radiation source centrally located inside the object and with the film outside (see Figures 5 to 7)

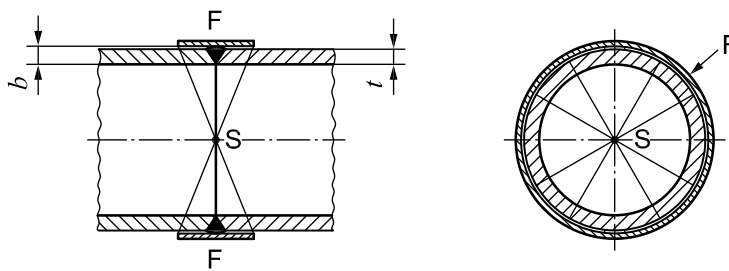

Figure 5 — Test arrangement for single wall penetration of curved objects

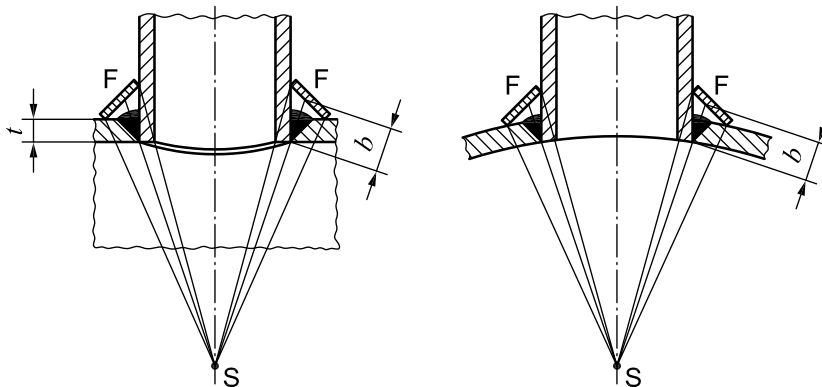

Figure 6 — Test arrangement for single wall penetration of curved objects (set-in weld)

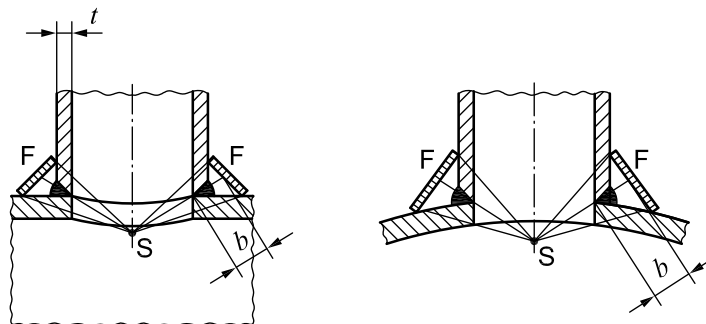

Figure 7 — Test arrangement for single wall penetration of curved objects (set-on weld)

7.1.5 Radiation source located off-centre inside the object and film outside (see Figures 8 to 10)

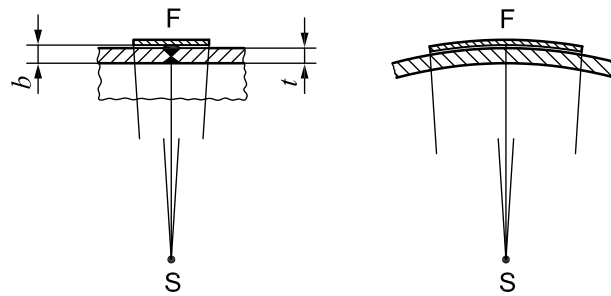

Figure 8 — Test arrangement for single wall penetration of curved objects

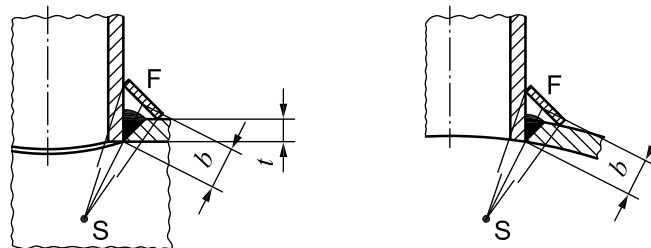

Figure 9 — Test arrangement for single wall penetration of curved object (set-in weld)

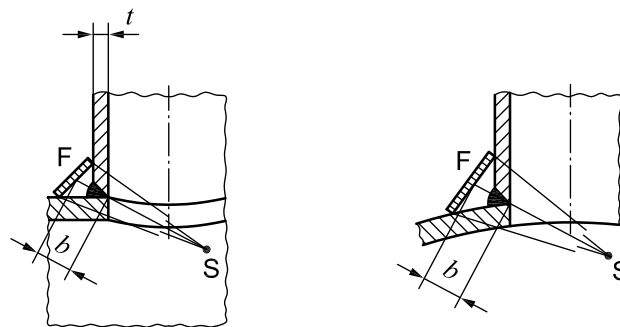
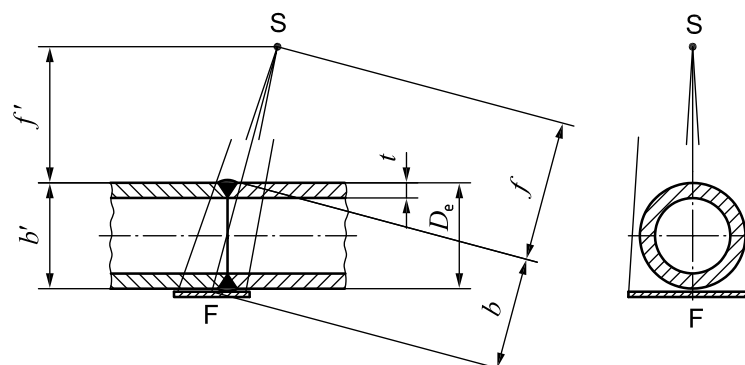

Figure 10 — Test arrangement for single wall penetration of curved objects (set-on weld)

7.1.6 Elliptic technique (see Figure 11)



NOTE The source-to-object distance can be calculated by the perpendicular distance f' , calculated from b' .

Figure 11 — Test arrangement for double wall penetration double image of curved objects for evaluation of both walls (source and film outside of the test object)

ISO 17636-1:2013(E)

7.1.7 Perpendicular technique (see Figure 12)

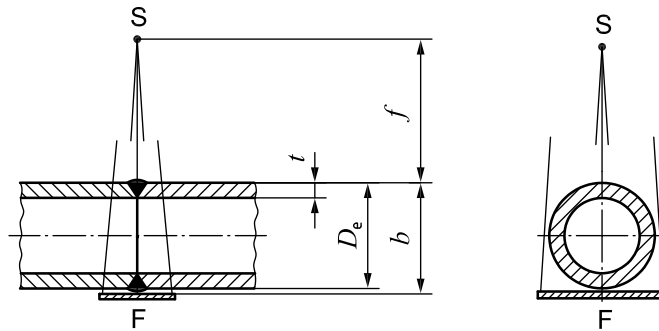

Figure 12 — Test arrangement for double wall penetration double image of curved objects for evaluation of both walls (source and film outside of the test object)

7.1.8 Radiation source located outside the object and film on the other side (see Figures 13 to 18)

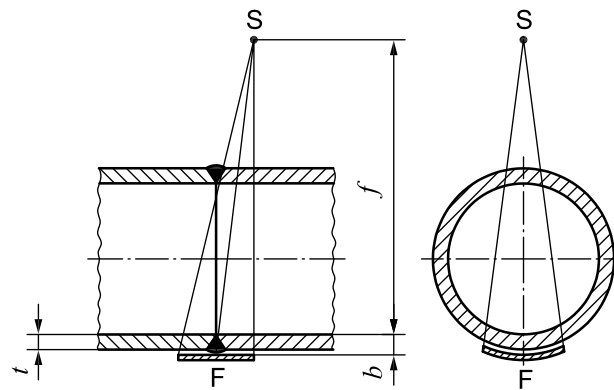

Figure 13 — Test arrangement for double wall penetration single image of curved objects for evaluation of the wall next to the film with the IQI placed close to the film

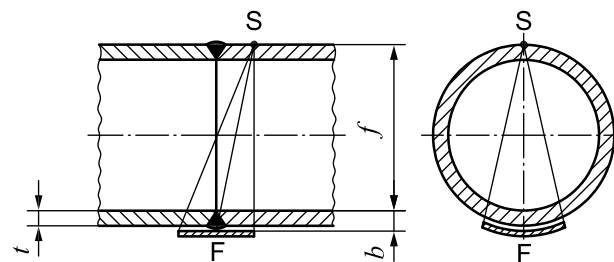

Figure 14 — Test arrangement for double wall penetration single image

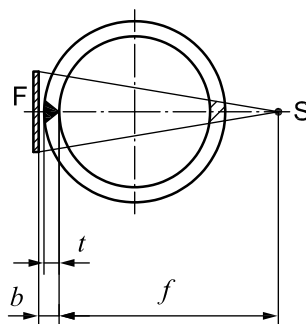

Figure 15 — Test arrangement for double wall penetration single image of longitudinal welds

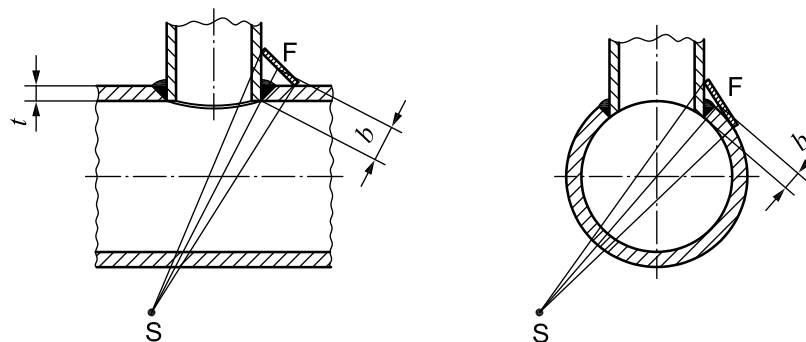

Figure 16 — Test arrangement for double wall penetration single image of curved objects for evaluation of the wall next to the film



Key

1 compensating edge

a) Test arrangement without compensating edge b) Test arrangement with compensating edge

Figure 17 — Test arrangement for penetration of fillet welds

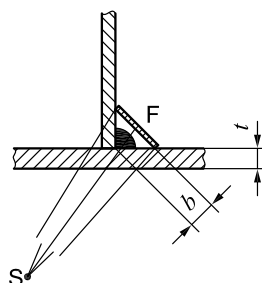

Figure 18 — Test arrangement for penetration of fillet welds

7.1.9 Technique for different material thicknesses (see Figure 19)

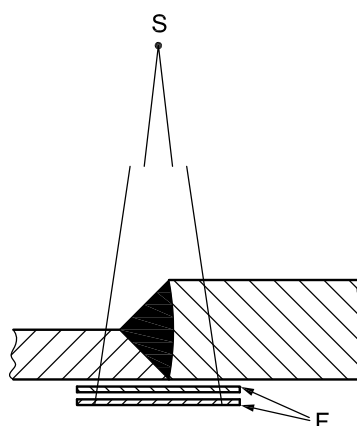

Figure 19 — Multi-film technique

ISO 17636-1:2013(E)

7.2 Choice of tube voltage and radiation source

7.2.1 X-ray devices up to 1 000 kV

To maintain a good flaw sensitivity, the X-ray tube voltage should be as low as possible. The maximum values of X-ray tube voltage versus thickness are given in Figure 20.

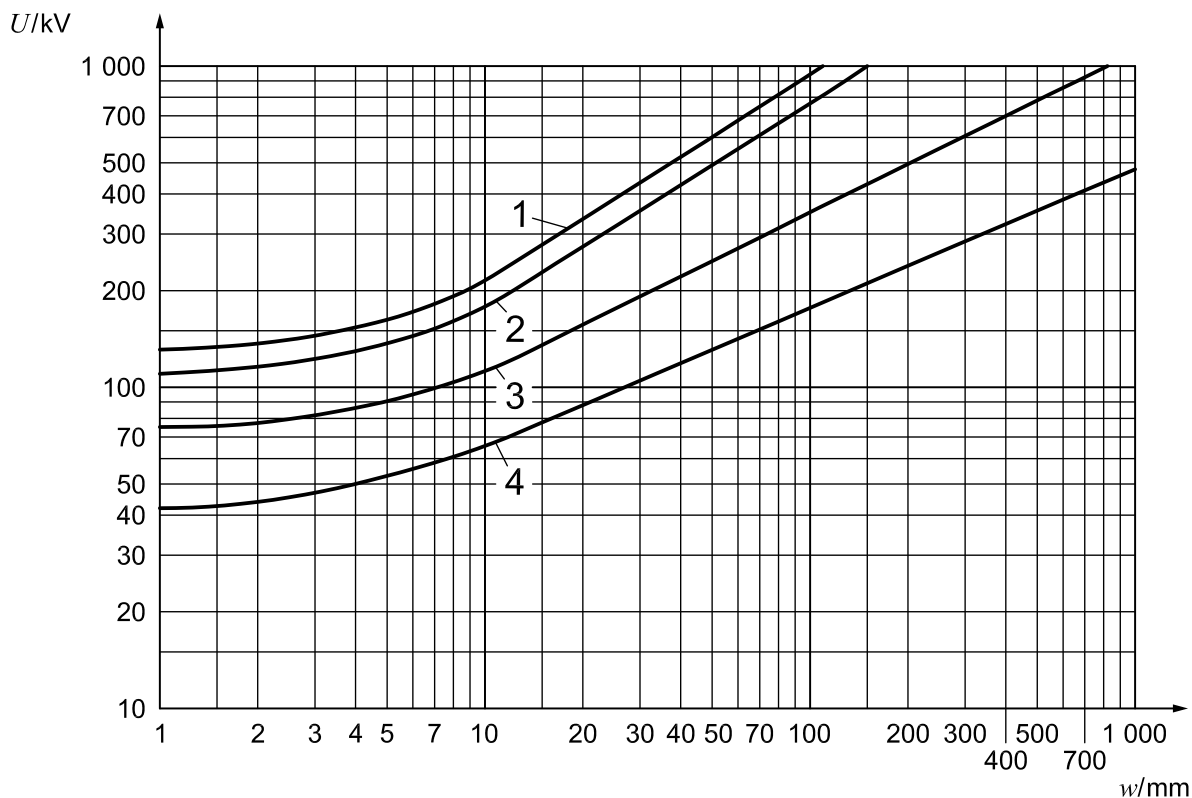
**Key**

U	X-ray voltage	1	copper and nickel and alloys
w	penetrated thickness	2	steel
		3	titanium and alloys
		4	aluminium and alloys

Figure 20 — Maximum X-ray voltage for X-ray devices up to 1 000 kV as a function of penetrated thickness and material

For some applications where there is a thickness change across the area of the object being radiographed, a modification of technique with a slightly higher voltage may be used, but it should be noted that an excessively high tube voltage leads to a loss of defect detection sensitivity. For steel, the increment shall be not more than 50 kV, for titanium not more than 40 kV, and for aluminium not more than 30 kV.

7.2.2 Other radiation sources

The permitted penetrated thickness ranges for gamma-ray sources and X-ray equipment above 1 MeV are given in Table 2.

By agreement between the contracting parties the value for Ir 192 may further be reduced to 10 mm and for Se 75 to 5 mm.

On thin steel specimens, gamma-rays from Se 75, Ir 192 and Co 60 sources do not produce radiographs having as good a defect detection sensitivity as X-rays used with appropriate technique parameters. However, because of the advantages of gamma-ray sources in handling and accessibility, Table 2 gives a range of thicknesses for which each of these gamma-ray sources may be used when the use of X-ray tubes is difficult.

For certain applications, wider wall thickness ranges may be permitted, if sufficient image quality can be achieved.

In cases where radiographs are produced using gamma-rays, the travel time to position the source shall not exceed 10 % of the total exposure time.

Table 2 — Penetrated thickness range for gamma-ray sources and X-ray equipment with energy above 1 MeV for steel, copper and nickel base alloys

Radiation source	Penetrated thickness <i>w</i> mm	
	Class A	Class B
Tm 170	$w \leq 5$	$w \leq 5$
Yb 169 ^a	$1 \leq w \leq 15$	$2 \leq w \leq 12$
Se 75 ^b	$10 \leq w \leq 40$	$14 \leq w \leq 40$
Ir 192	$20 \leq w \leq 100$	$20 \leq w \leq 90$
Co 60	$40 \leq w \leq 200$	$60 \leq w \leq 150$
X-ray equipment with energy from 1 MeV to 4 MeV	$30 \leq w \leq 200$	$50 \leq w \leq 180$
X-ray equipment with energy from 4 MeV to 12 MeV	$w \geq 50$	$w \geq 80$
X-ray equipment with energy above 12 MeV	$w \geq 80$	$w \geq 100$

^a For aluminium and titanium, the penetrated material thickness is $10 \text{ mm} \leq w \leq 70 \text{ mm}$ for class A and $25 \text{ mm} \leq w \leq 55 \text{ mm}$ for class B.

^b For aluminium and titanium, the penetrated material thickness is $35 \text{ mm} \leq w \leq 120 \text{ mm}$ for class A.

7.3 Film systems and metal screens

For radiographic examination, film system classes shall be used in accordance with ISO 11699-1.

For different radiation sources, the minimum film system classes are given in Tables 3 and 4.

When using metal screens, good contact between films and screens is required. This may be achieved either by using vacuum-packed films or by applying pressure.

For different radiation sources, Tables 3 and 4 show the recommended screens materials and thickness.

Other screen thicknesses may be also agreed between the contracting parties, provided the required image quality is achieved.

ISO 17636-1:2013(E)

Table 3 — Film system classes and metal screens for the radiography of steels, copper and nickel based alloys

Radiation source	Penetrated thickness w	Film system class ^a		Type and thickness of metal screens	
		Class A	Class B	Class A	Class B
X-ray potentials ≤ 100 kV		C 5	C 3	none or up to 0,03 mm front and back screens of lead	
X-ray potentials >100 kV to 150 kV				up to 0,15 mm front and back screens of lead	
X-ray potentials >150 kV to 250 kV			C 4	0,02 mm to 0,15 mm front and back screens of lead	
Yb 169	$w < 5$ mm	C 5	C 3	none or up to 0,03 mm front and back screens of lead	
Tm 170	$w \geq 5$ mm		C 4	0,02 mm to 0,15 mm front and back screens of lead	
X-ray potentials >250 kV to 500 kV	$w \leq 50$ mm	C 5	C 4	0,02 mm to 0,2 mm front and back screens of lead	
	$w > 50$ mm		C 5	0,1 mm to 0,2 mm front screens of lead ^b 0,02 mm to 0,2 mm back screens of lead	
X-ray potentials >500 kV to 1000 kV	$w < 75$ mm	C 5	C 4	0,25 mm to 0,7 mm front and back screens of steel or copper ^c	
	$w > 75$ mm	C 5	C 5		
Se 75		C 5	C 4	0,02 mm to 0,2 mm front and back screens of lead	
Ir 192		C 5	C 4	0,02 mm to 0,2 mm front screens of lead	0,1 mm to 0,2 mm front screens of lead ^b
				0,02 mm to 0,2 mm back screens of lead	
Co 60	$w \leq 100$ mm	C 5	C 4	0,25 mm to 0,7 mm front and back screens of steel or copper ^c	
	$w > 100$ mm		C 5		
X-ray equipment with energy from 1 MeV to 4 MeV	$w \leq 100$ mm	C 5	C 3	0,25 mm to 0,7 mm front and back screens of steel or copper ^c	
	$w > 100$ mm		C 5		
X-ray equipment with energy from 4 MeV to 12 MeV	$w \leq 100$ mm	C 4	C 4	up to 1 mm front screen of copper, steel or tantalum ^d	
	$100 \text{ mm} < w \leq 300$ mm	C 5	C 4	back screen of copper or steel up to 1 mm and tantalum up to 0,5 mm ^d	
	$w > 300$ mm		C 5		
X-ray equipment with energy above 12 MeV	$w \leq 100$ mm	C 4	Not applicable	up to 1 mm front screen of tantalum ^e No back screen	
	$100 \text{ mm} < w \leq 300$ mm	C 5	C 4	up to 1 mm front screen of tantalum ^e up to 0,5 mm back screen of tantalum	
	$w > 300$ mm		C 5		

^a Better film system classes may also be used, see ISO 11699-1.

^b Ready packed films with a front screen up to 0,03 mm may be used if an additional lead screen of 0,1 mm is placed between the object and the film.

^c In class A, 0,5 mm to 2,0 mm screens of lead may also be used.

^d In class A, lead screens 0,5 mm to 1 mm may be used by agreement between the contracting parties.

^e Tungsten screens may be used by agreement.

Table 4 — Film system classes and metal screens for aluminium and titanium

Radiation source	Film system class ^a		Type and thickness of intensifying screens
	Class A	Class B	
X-ray potentials ≤150 kV	C 5	C 3	none or up to 0,03 mm front and up to 0,15 mm back screens of lead
X-ray potentials >150 kV to 250 kV			0,02 mm to 0,15 mm front and back screens of lead
X-ray potentials >250 kV to 500 kV			0,1 mm to 0,2 mm front and back screens of lead
Yb 169			0,02 mm to 0,15 mm front and back screens of lead
Se 75			0,2 mm front ^b and 0,1 mm to 0,2 mm back screens of lead
^a Better film system classes may also be used, see ISO 11699-1. ^b Instead of one 0,2 mm lead screen, two 0,1 mm lead screens may be used.			

7.4 Alignment of beam

The beam of radiation shall be directed to the centre of the area being examined and should be perpendicular to the object surface at that point, except when it can be demonstrated that certain imperfections are best revealed by a different alignment of the beam. In this case, an appropriate alignment of the beam is permitted. Other ways of radiographing may be agreed between the contracting parties.

EXAMPLE For better detection of lack of side wall fusion, the beam direction should be aligned with the weld preparation angles.

7.5 Reduction of scattered radiation

7.5.1 Metal filters and collimators

In order to reduce the effect of backscattered radiation, direct radiation shall be collimated as much as possible to the section under examination.

With Se 75, Ir 192, and Co 60 radiation sources or in the case of edge scatter a sheet of lead can be used as a filter of low energy scattered radiation between the object and the cassette. The thickness of this sheet is 0,5 mm to 2 mm in accordance with the penetrated thickness.

7.5.2 Interception of backscattered radiation

The presence of backscattered radiation shall be checked for each new test arrangement by means of a lead letter B (with a minimum height of 10 mm and a minimum thickness of 1,5 mm) placed immediately behind each cassette. If the image of this symbol records as a lighter image on the radiograph, it shall be rejected. If the symbol is darker or invisible the radiograph is acceptable and demonstrates good protection against backscattered radiation.

If necessary, the film shall be shielded from backscattered radiation by a sheet of lead of at least 1 mm thickness, or a sheet of tin of at least 1,5 mm thickness, placed behind the film–screen combination.

7.6 Source-to-object distance

The minimum source-to-object distance f_{\min} depends on the source size or focal spot size d and on the object-to-film distance b . The source size or focal spot size d shall be in accordance with EN 12543 or EN 12679.

ISO 17636-1:2013(E)

When the source size or focal spot size is defined by two dimensions, the larger shall be used.

The distance f shall, where practicable, be chosen so that the ratio of this distance to the source size or focal spot size d , i.e. f/d , is not less than the values given by Formulae (1) and (2):

$$\frac{f}{d} \geq 7,5b^{2/3} \quad (1)$$

for class A, and for class B,

$$\frac{f}{d} \geq 15b^{2/3} \quad (2)$$

where b is expressed in millimetres.

If the distance b is less than $1,2t$ then the dimension b in Formulae (1) and (2) and Figure 21 shall be replaced by the nominal thickness t .

For determination of the source-to-object distance f_{\min} , the nomogram in Figure 21 may be used.

This nomogram is based on Formulae (1) and (2).

In class A, if detection of planar imperfections is a requirement, the minimum distance f_{\min} shall be the same as for class B in order to reduce the geometric unsharpness by a factor of 2.

In critical technical applications of crack-sensitive materials, more sensitive radiographic techniques than class B shall be used.

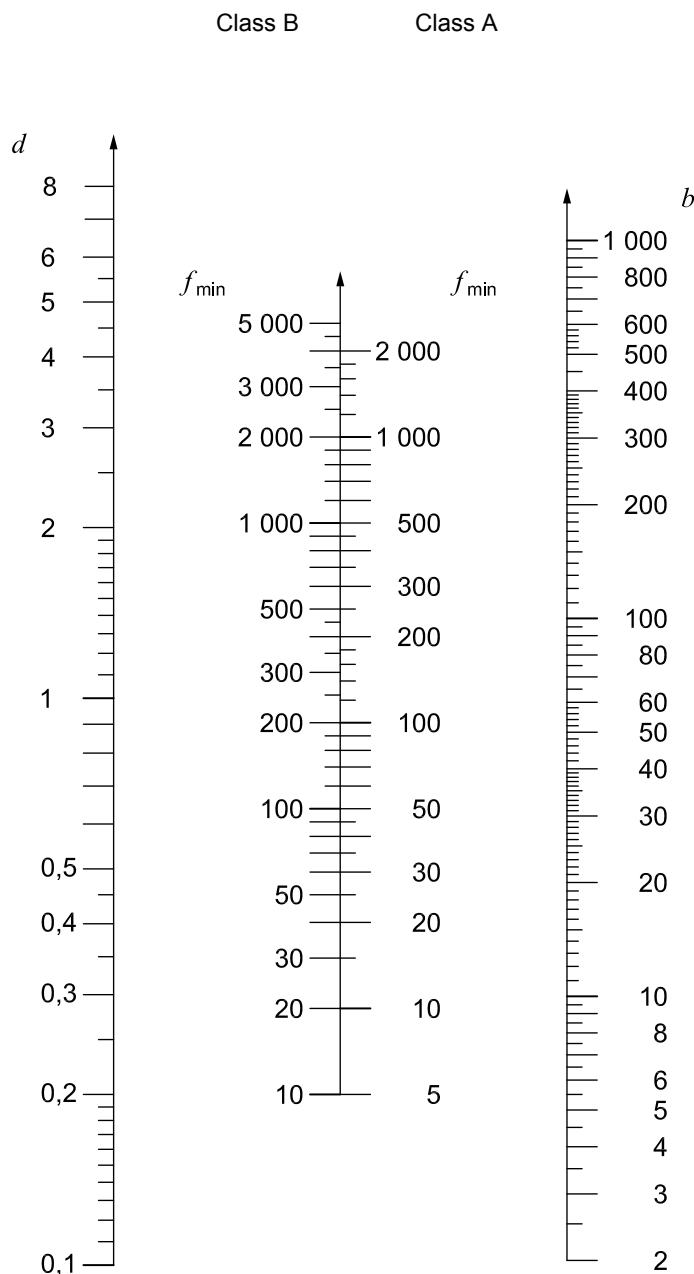

Figure 21 — Nomogram for the determination of minimum source-to-object distance f_{\min} in relation to object-to-film distance b and the source size d

When using the elliptic technique specified in 7.1.6 or the perpendicular technique specified in 7.1.7, b shall be replaced by the external diameter, D_e , of the pipe in Formulae (1) and (2) and in Figure 21.

When the source is outside the object and film on the other side (technique specified in 7.1.8 as double wall penetration and single image) the minimum source-to-object distance is determined only by the wall thickness (i.e. not by the pipe diameter).

Where possible, it is preferable to avoid usage of a double wall technique (see 7.1.6 to 7.1.8) by placing the radiation source inside the object to be radiographed, to achieve a more suitable direction of examination (see 7.1.4 and 7.1.5). The reduction in minimum source-to-object distance should not be greater than 20 %.

When the source is located centrally inside the object and film outside (technique shown in 7.1.4) and provided that the IQI requirements are met, this percentage may be increased. However, the reduction in

ISO 17636-1:2013(E)

minimum source-to-object distance shall not be greater than 50 %. A further reduction can be agreed by the contracting parties provided that the IQI requirements are met.

7.7 Maximum area for a single exposure

The number of radiographs for a complete examination of flat welds (see Figures 1, 15, 17, and 18) and of curved welds with the radiation source arranged off-centre (see Figures 2 to 4 and 8 to 16) should be specified in accordance with technical requirements.

The ratio of the penetrated thickness at the outer edge of an evaluated area of uniform thickness to that at the centre beam shall not be more than 1,1 for class B and 1,2 for class A.

The densities resulting from any variation of penetrated thickness should not be lower than those indicated in 7.8 and not higher than those allowed by the available illuminator, provided suitable masking is possible.

The size of the area to be examined includes the weld and the heat-affected zones. In general, about 10 mm of parent metal shall be examined on each side of the weld.

Recommendations for the number of radiographs are indicated in Annex A which gives an acceptable examination of a circumferential butt weld.

7.8 Density of radiograph

Exposure conditions should be such that the minimum optical density of the radiograph in the area examined is greater than or equal to those given in Table 5.

Table 5 — Optical density of the radiographs

Class	Optical density ^a
A	$\geq 2,0^b$
B	$\geq 2,3^c$
^a A measuring tolerance of $\pm 0,1$ is permitted. ^b The value may be reduced by special agreement between the contracting parties to 1,5. ^c The value may be reduced by special agreement between the contracting parties to 2,0.	

High optical densities can be used with advantage where the viewing light is sufficiently bright in accordance with 7.10. The maximum readable film density depends on the film viewer used and its maximum luminance (see ISO 5580). The maximum readable density shall be posted on the viewer.

In order to avoid unduly high fog densities arising from film ageing, development or temperature, the fog density shall be checked periodically on a non-exposed sample taken from the films being used, and handled and processed under the same conditions as the actual radiograph. The fog density shall not exceed 0,3. Fog density here is defined as the total density (emulsion and base) of a processed, unexposed film.

When using a multi-film technique with interpretation of single films, the optical density of each film shall be in accordance with Table 5.

If double film viewing is requested, the optical density of one single film shall not be lower than 1,3.

7.9 Processing

Films are processed in accordance with the conditions recommended by the film and chemical manufacturer to obtain the selected film system class. Particular attention shall be paid to temperature, developing time and washing time. The film processing shall be controlled regularly in accordance with ISO 11699-2. The

radiographs should be free from defects due to processing or other causes which would interfere with interpretation.

7.10 Film viewing conditions

The radiographs should be examined in a darkened room on an area of the viewing screen with an adjustable luminance in accordance with ISO 5580. The viewing screen should be masked to the area of interest.

8 Test report

For each exposure, or set of exposures, a test report shall be made giving information on the radiographic technique used, and on any other special circumstances which would allow a better understanding of the results.

The test report shall include at least the following information:

- a) name of the examination body;
- b) object;
- c) material;
- d) heat treatment;
- e) geometry of the weld;
- f) material thickness;
- g) welding process;
- h) specification of examination including requirements for acceptance;
- i) radiographic technique and class, required IQI sensitivity in accordance with this part of ISO 17636 (ISO 17636-1:2012);
- j) test arrangement in accordance with 7.1;
- k) system of marking used;
- l) film position plan;
- m) radiation source, type and size of focal spot and identification of equipment used;
- n) film type and system, screens and filters;
- o) tube voltage used and current or source type and activity;
- p) time of exposure and source-to-film distance;
- q) processing technique: manual/automatic, and development conditions;
- r) type and position of image quality indicators;
- s) results of examination including data on film density, IQI readings;
- t) any deviation from this part of ISO 17636, by special agreement;

ISO 17636-1:2013(E)

- u) name, certification and signature of the responsible person(s);
- v) date(s) of exposure and test report.

Annex A (normative)

Recommended number of exposures which give an acceptable examination of a circumferential butt weld

The minimum number of exposures required is presented in Figures A.1 to A.4 which are valid for pipes with an external diameter exceeding 100 mm.

When the deviation of the wall thickness of the joint to be examined, when using a single exposure $\Delta t/t$ does not exceed 20 %, Figures A.3 and A.4 are used. This technique is recommended only when the possibility of having transverse cracks is small or the weld is examined for such imperfections by other non-destructive examination methods.

When $\Delta t/t$ is less than or equal to 10 %, Figures A.1 and A.2 are used. In this case, it is likely that transverse cracks are also detected.

If the object is examined for single transverse cracks, then the required minimum number of radiographs increases compared with the values in Figures A.1 to A.4.

ISO 17636-1:2013(E)

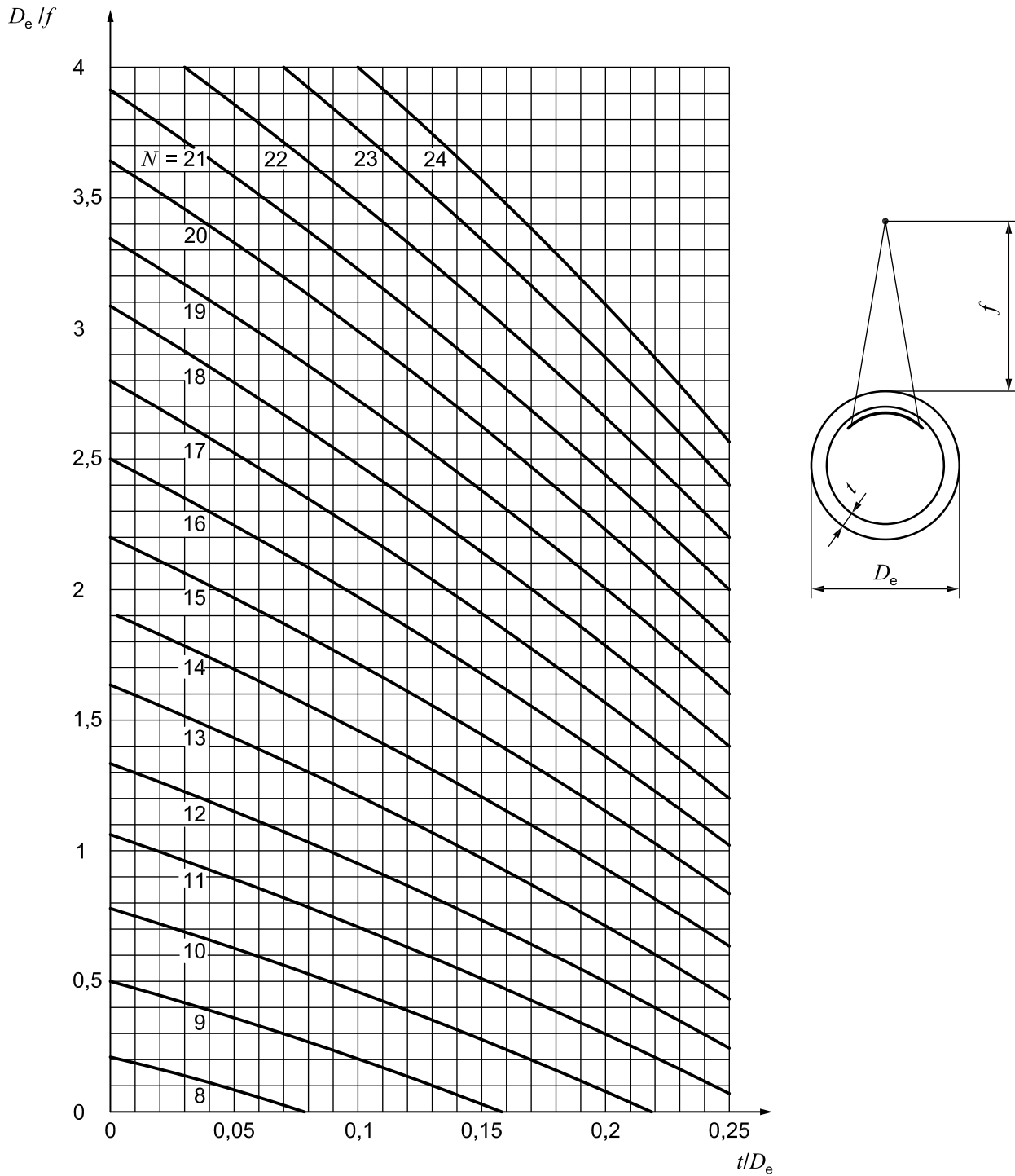
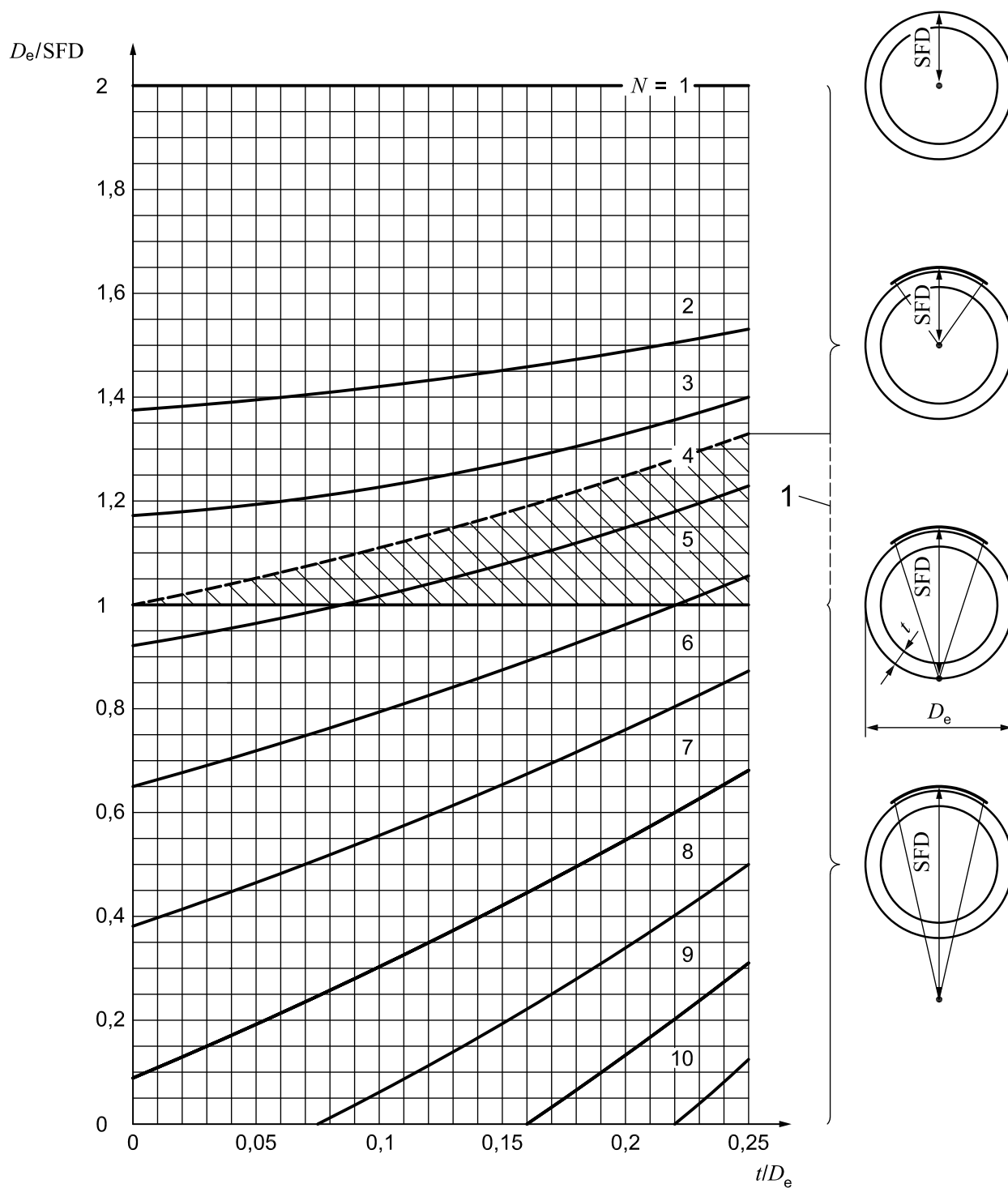

Figure A.1 — Minimum number of exposures N for single wall penetration with source outside, with a maximum permissible increase in penetrated thickness $\Delta t/t$ due to inclined penetration in the areas to be evaluated of 10 % (class B), as a function of ratios t/D_e and D_e/f



Key

1 inside pipe wall (not accessible)

Figure A.2 — Minimum number of exposures N for off-centre penetration with source inside and for double wall penetration, with a maximum permissible increase in penetrated thickness $\Delta t/t$ due to inclined penetration in the areas to be evaluated of 10 % (class B), as a function of ratios t/D_e and D_e/SFD

ISO 17636-1:2013(E)

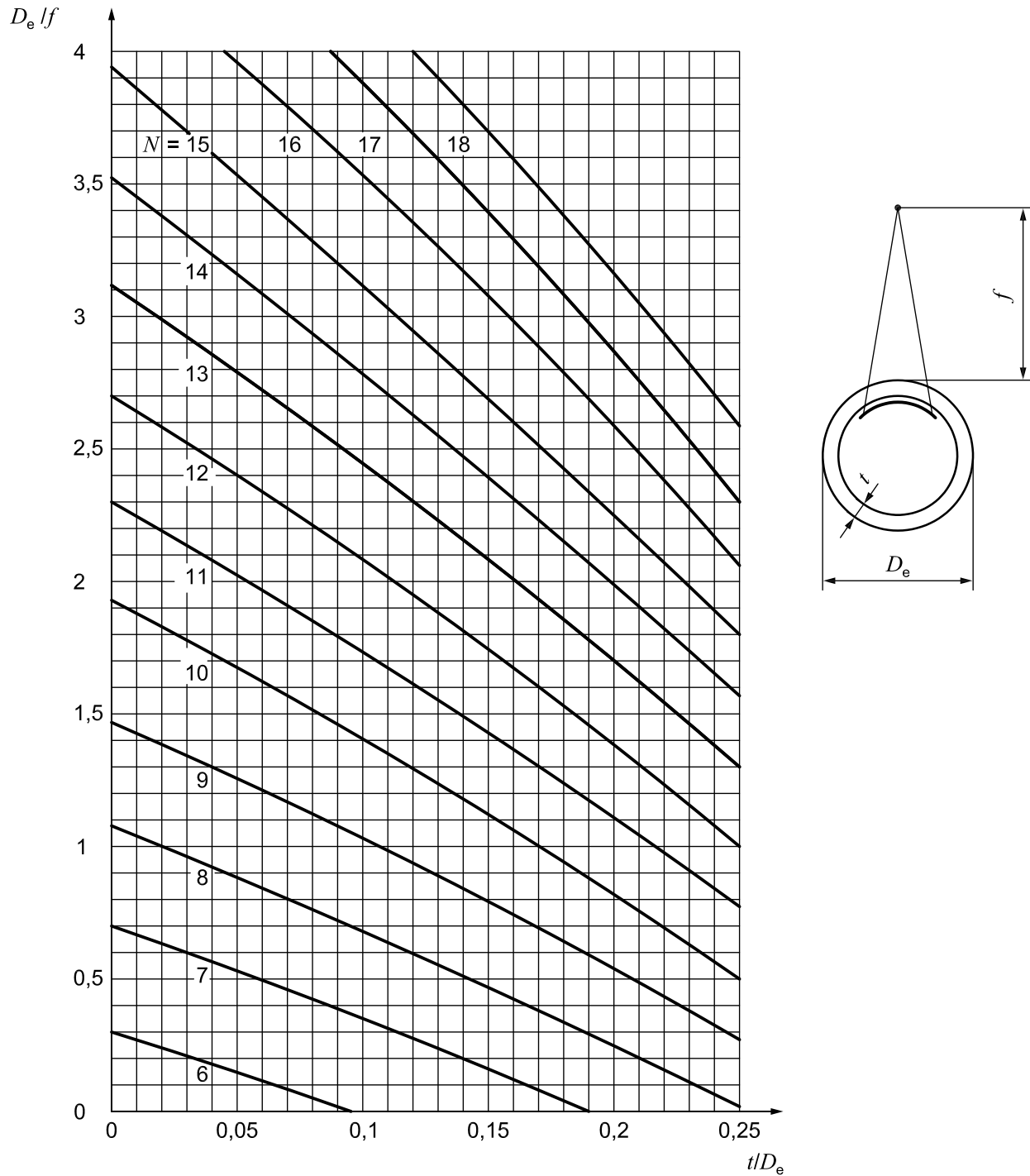
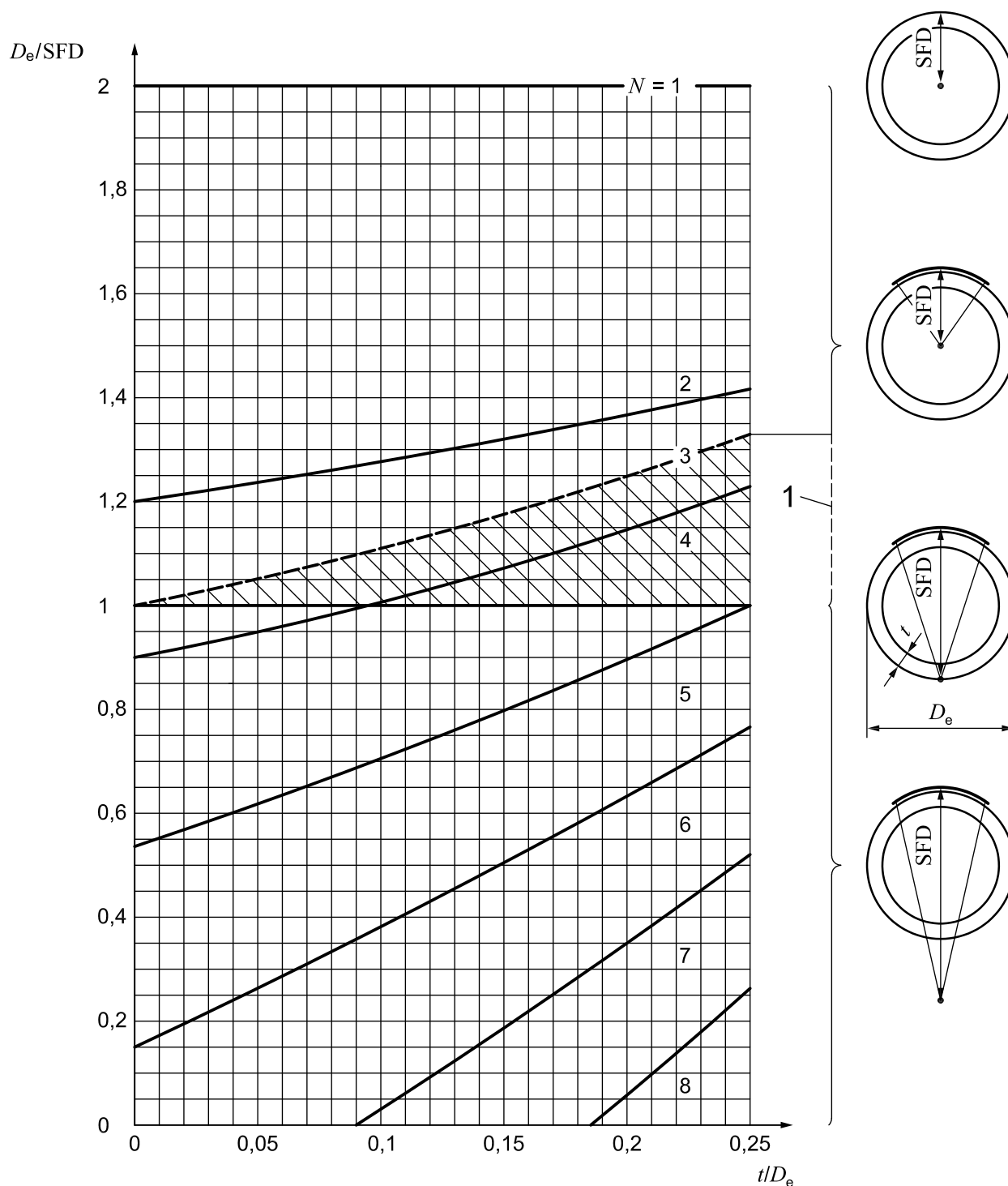

Figure A.3 — Minimum number of exposures N for single wall penetration with source outside, with a maximum permissible increase in penetrated thickness $\Delta t/t$ due to inclined penetration in the areas to be evaluated of 20 % (class A), as a function of ratios t/D_e and D_e/f

**Key**

1 inside pipe wall (not accessible)

Figure A.4 — Minimum number of exposures N for off-centre penetration with source inside and for double wall penetration, with a maximum permissible increase in penetrated thickness $\Delta t/t$ due to inclined penetration in the areas to be evaluated of 20 % (class A), as a function of ratios t/D_e and D_e/SFD

ISO 17636-1:2013(E)

Annex B
(normative)

Minimum image quality values

B.1 Single-wall technique; IQI on source side

Table B.1 — Wire IQI

Image quality class A			
Nominal thickness t mm			IQI value
	to	1,2	W 18
above	1,2	to 2,0	W 17
above	2,0	to 3,5	W 16
above	3,5	to 5,0	W 15
above	5,0	to 7	W 14
above	7	to 10	W 13
above	10	to 15	W 12
above	15	to 25	W 11
above	25	to 32	W 10
above	32	to 40	W 9
above	40	to 55	W 8
above	55	to 85	W 7
above	85	to 150	W 6
above	150	to 250	W 5
above	250		W 4

Table B.2 — Step hole IQI

Image quality class A			
Nominal thickness t mm			IQI value
	to	2,0	H 3
above	2,0	to 3,5	H 4
above	3,5	to 6	H 5
above	6	to 10	H 6
above	10	to 15	H 7
above	15	to 24	H 8
above	24	to 30	H 9
above	30	to 40	H 10
above	40	to 60	H 11
above	60	to 100	H 12
above	100	to 150	H 13
above	150	to 200	H 14
above	200	to 250	H 15
above	250	to 320	H 16
above	320	to 400	H 17
above	400		H 18

Table B.3 — Wire IQI

Image quality class B			
Nominal thickness t mm			IQI value
	to	1,5	W 19
above	1,5	to 2,5	W 18
above	2,5	to 4	W 17
above	4	to 6	W 16
above	6	to 8	W 15
above	8	to 12	W 14
above	12	to 20	W 13
above	20	to 30	W 12
above	30	to 35	W 11
above	35	to 45	W 10
above	45	to 65	W 9
above	65	to 120	W 8
above	120	to 200	W 7
above	200	to 350	W 6
above	350		W 5

Table B.4 — Step hole IQI

Image quality class B			
Nominal thickness t mm			IQI value
	to	2,5	H 2
above	2,5	to 4	H 3
above	4	to 8	H 4
above	8	to 12	H 5
above	12	to 20	H 6
above	20	to 30	H 7
above	30	to 40	H 8
above	40	to 60	H 9
above	60	to 80	H 10
above	80	to 100	H 11
above	100	to 150	H 12
above	150	to 200	H 13
above	200	to 250	H 14

ISO 17636-1:2013(E)

B.2 Double-wall technique; double image; IQI on source side

Table B.5 — Wire IQI

Image quality class A			
Penetrated thickness w mm			IQI value
		to 1,2	W 18
above	1,2	to 2	W 17
above	2	to 3,5	W 16
above	3,5	to 5	W 15
above	5	to 7	W 14
above	7	to 12	W 13
above	12	to 18	W 12
above	18	to 30	W 11
above	30	to 40	W 10
above	40	to 50	W 9
above	50	to 60	W 8
above	60	to 85	W 7
above	85	to 120	W 6
above	120	to 220	W 5
above	220	to 380	W 4
above	380		W 3

Table B.6 — Step hole IQI

Image quality class A			
Penetrated thickness w mm			IQI value
		to 1	H 3
above	1	to 2	H 4
above	2	to 3,5	H 5
above	3,5	to 5,5	H 6
above	5,5	to 10	H 7
above	10	to 19	H 8
above	19	to 35	H 9

Table B.7 — Wire IQI

Image quality class B			
Penetrated thickness w mm			IQI value
		to 1,5	W 19
above	1,5	to 2,5	W 18
above	2,5	to 4	W 17
above	4	to 6	W 16
above	6	to 8	W 15
above	8	to 15	W 14
above	15	to 25	W 13
above	25	to 38	W 12
above	38	to 45	W 11
above	45	to 55	W 10
above	55	to 70	W 9
above	70	to 100	W 8
above	100	to 170	W 7
above	170	to 250	W 6
above	250		W 5

Table B.8 — Step hole IQI

Image quality class B			
Penetrated thickness w mm			IQI value
		to 1	H 2
above	1	to 2,5	H 3
above	2,5	to 4	H 4
above	4	to 6	H 5
above	6	to 11	H 6
above	11	to 20	H 7
above	20	to 35	H 8

B.3 Double wall technique: single or double image; IQI on film side**Table B.9 — Wire IQI**

Image quality class A			
Penetrated thickness w mm			IQI value
		to 1,2	W 18
above	1,2	to 2	W 17
above	2	to 3,5	W 16
above	3,5	to 5	W 15
above	5	to 10	W 14
above	10	to 15	W 13
above	15	to 22	W 12
above	22	to 38	W 11
above	38	to 48	W 10
above	48	to 60	W 9
above	60	to 85	W 8
above	85	to 125	W 7
above	125	to 225	W 6
above	225	to 375	W 5
above	375		W 4

Table B.10 — Step hole IQI

Image quality class A			
Penetrated thickness w mm			IQI value
		to 2	H 3
above	2	to 5	H 4
above	5	to 9	H 5
above	9	to 14	H 6
above	14	to 22	H 7
above	22	to 36	H 8
above	36	to 50	H 9
above	50	to 80	H 10

Table B.11 — Wire IQI

Image quality class B			
Penetrated thickness w mm			IQI value
		to 1,5	W 19
above	1,5	to 2,5	W 18
above	2,5	to 4	W 17
above	4	to 6	W 16
above	6	to 12	W 15
above	12	to 18	W 14
above	18	to 30	W 13
above	30	to 45	W 12
above	45	to 55	W 11
above	55	to 70	W 10
above	70	to 100	W 9
above	100	to 180	W 8
above	180	to 300	W 7
above	300		W 6

Table B.12 — Step hole IQI

Image quality class B			
Penetrated thickness w mm			IQI value
		to 2,5	H 2
above	2,5	to 5,5	H 3
above	5,5	to 9,5	H 4
above	9,5	to 15	H 5
above	15	to 24	H 6
above	24	to 40	H 7
above	40	to 60	H 8
above	60	to 80	H 9

Bibliography

- [1] ISO 5579, *Non-destructive testing — Radiographic examination of metallic materials using film and X- or gamma-rays — Basic rules*
- [2] ISO 19232-3, *Non-destructive testing — Image quality of radiographs — Part 3: Image quality classes for ferrous metals*

ISO 17636-1:2013(E)

ICS 25.160.40

Price based on 30 pages