



P O L S K A N O R M A

ICS 25.160.40

PN-EN ISO 17636-2

Wprowadza
EN ISO 17636-2:2013, IDT
ISO 17636-2:2013, IDT

Zastępuje
-

Badania nieniszczące spoin

Badanie radiograficzne

**Część 2: Techniki promieniowania X i gamma
z detektorami cyfrowymi**

Norma Europejska EN ISO 17636-2:2013 *Non-destructive testing of welds - Radiographic testing - Part 2: X- and gamma-ray techniques with digital detectors (ISO 17636-2:2013)* ma status Polskiej Normy

© Copyright by PKN, Warszawa 2013

nr ref. PN-EN ISO 17636-2:2013-06

Wszelkie prawa autorskie zastrzeżone. Żadna część niniejszej publikacji nie może być zwielokrotniana jakkolwiek techniką bez pisemnej zgody Prezesa Polskiego Komitetu Normalizacyjnego

ISBN 978-83-275-1270-3

PN-EN ISO 17636-2:2013-06

Przedmowa krajowa

Niniejsza norma została zatwierdzona przez Prezesa PKN dnia 24 czerwca 2013 r.

Komitetem krajowym odpowiedzialnym za normę jest KT nr 165 ds. Spawania i Procesów Pokrewnych.

Istnieje możliwość przetłumaczenia normy na język polski na wniosek zainteresowanych środowisk. Decyzję podejmuje właściwy Komitet Techniczny.

Odpowiedniki krajowe norm i innych dokumentów powołanych w niniejszej normie można znaleźć w katalogu Polskich Norm. Oryginały norm i innych dokumentów powołanych są dostępne w PKN.

W sprawach merytorycznych dotyczących treści normy można zwracać się do właściwego Komitetu Technicznego lub właściwej Rady Sektorowej PKN, kontakt: www.pkn.pl

Nota uznaniowa

Norma Europejska EN ISO 17636-2:2013 została uznana przez PKN za Polską Normę PN-EN ISO 17636-2:2013-06.

EUROPEAN STANDARD

EN ISO 17636-2

NORME EUROPÉENNE

EUROPÄISCHE NORM

January 2013

ICS 25.160.40

Supersedes EN 1435:1997

English Version

**Non-destructive testing of welds - Radiographic testing - Part 2:
X- and gamma-ray techniques with digital detectors (ISO 17636-
2:2013)**

Contrôle non destructif des assemblages soudés - Contrôle
par radiographie - Partie 2: Techniques par rayons X ou
gamma à l'aide de détecteurs numériques (ISO 17636-
2:2013)

Zerstörungsfreie Prüfung von Schweißverbindungen -
Durchstrahlungsprüfung - Teil 2: Röntgen- und
Gammastrahlungstechniken mit digitalen Detektoren (ISO
17636-2:2013)

This European Standard was approved by CEN on 14 December 2012.

CEN members are bound to comply with the CEN/CENELEC Internal Regulations which stipulate the conditions for giving this European Standard the status of a national standard without any alteration. Up-to-date lists and bibliographical references concerning such national standards may be obtained on application to the CEN-CENELEC Management Centre or to any CEN member.

This European Standard exists in three official versions (English, French, German). A version in any other language made by translation under the responsibility of a CEN member into its own language and notified to the CEN-CENELEC Management Centre has the same status as the official versions.

CEN members are the national standards bodies of Austria, Belgium, Bulgaria, Croatia, Cyprus, Czech Republic, Denmark, Estonia, Finland, Former Yugoslav Republic of Macedonia, France, Germany, Greece, Hungary, Iceland, Ireland, Italy, Latvia, Lithuania, Luxembourg, Malta, Netherlands, Norway, Poland, Portugal, Romania, Slovakia, Slovenia, Spain, Sweden, Switzerland, Turkey and United Kingdom.



EUROPEAN COMMITTEE FOR STANDARDIZATION
COMITÉ EUROPÉEN DE NORMALISATION
EUROPÄISCHES KOMITEE FÜR NORMUNG

Management Centre: Avenue Marnix 17, B-1000 Brussels

EN ISO 17636-2:2013 (E)

Contents

Page

Foreword.....3

Foreword

This document (EN ISO 17636-2:2013) has been prepared by Technical Committee CEN/TC 121 "Welding" the secretariat of which is held by DIN, in collaboration with Technical Committee ISO/TC 44 "Welding and allied processes".

This European Standard shall be given the status of a national standard, either by publication of an identical text or by endorsement, at the latest by July 2013, and conflicting national standards shall be withdrawn at the latest by July 2013.

Attention is drawn to the possibility that some of the elements of this document may be the subject of patent rights. CEN [and/or CENELEC] shall not be held responsible for identifying any or all such patent rights.

This document supersedes EN 1435:1997.

According to the CEN/CENELEC Internal Regulations, the national standards organisations of the following countries are bound to implement this European Standard: Austria, Belgium, Bulgaria, Croatia, Cyprus, Czech Republic, Denmark, Estonia, Finland, Former Yugoslav Republic of Macedonia, France, Germany, Greece, Hungary, Iceland, Ireland, Italy, Latvia, Lithuania, Luxembourg, Malta, Netherlands, Norway, Poland, Portugal, Romania, Slovakia, Slovenia, Spain, Sweden, Switzerland, Turkey and the United Kingdom.

INTERNATIONAL STANDARD

ISO
17636-2

First edition
2013-01-15

Non-destructive testing of welds — Radiographic testing —

Part 2:

X- and gamma-ray techniques with digital detectors

*Contrôle non destructif des assemblages soudés — Contrôle par
radiographie —*

*Partie 2: Techniques par rayons X ou gamma à l'aide de détecteurs
numériques*



Reference number
ISO 17636-2:2013(E)

© ISO 2013

ISO 17636-2:2013(E)



COPYRIGHT PROTECTED DOCUMENT

© ISO 2013

All rights reserved. Unless otherwise specified, no part of this publication may be reproduced or utilized in any form or by any means, electronic or mechanical, including photocopying and microfilm, without permission in writing from either ISO at the address below or ISO's member body in the country of the requester.

ISO copyright office
Case postale 56 • CH-1211 Geneva 20
Tel. + 41 22 749 01 11
Fax + 41 22 749 09 47
E-mail copyright@iso.org
Web www.iso.org

Published in Switzerland

Contents

Page

Foreword	iv
Introduction.....	v
1 Scope	1
2 Normative references	1
3 Terms and definitions	2
4 Symbols and terms	5
5 Classification of radiographic techniques.....	6
6 General	7
6.1 Protection against ionizing radiation	7
6.2 Surface preparation and stage of manufacture	7
6.3 Location of the weld in the radiograph	8
6.4 Identification of radiographs	8
6.5 Marking	8
6.6 Overlap of digital images.....	8
6.7 Types and positions of image quality indicators (IQI).....	8
6.8 Minimum image quality values	9
6.9 Personnel qualification	10
7 Recommended techniques for making digital radiographs.....	10
7.1 Test arrangements	10
7.2 Choice of tube voltage and radiation source	16
7.3 Detector systems and metal screens	18
7.4 Alignment of beam	20
7.5 Reduction of scattered radiation	20
7.6 Source-to-object distance	22
7.7 Geometric magnification technique	25
7.8 Maximum area for a single exposure	26
7.9 Processing	26
7.10 Monitor viewing conditions and storage of digital radiographs	27
8 Examination report.....	28
Annex A (normative) Recommended number of exposures which give an acceptable examination of a circumferential butt weld	30
Annex B (normative) Minimum image quality values	35
Annex C (normative) Determination of basic spatial resolution.....	41
Annex D (normative) Determination of minimum grey values for CR practice	45
Annex E (informative) Grey values, general remarks.....	50
Bibliography.....	52

ISO 17636-2:2013(E)

Foreword

ISO (the International Organization for Standardization) is a worldwide federation of national standards bodies (ISO member bodies). The work of preparing International Standards is normally carried out through ISO technical committees. Each member body interested in a subject for which a technical committee has been established has the right to be represented on that committee. International organizations, governmental and non-governmental, in liaison with ISO, also take part in the work. ISO collaborates closely with the International Electrotechnical Commission (IEC) on all matters of electrotechnical standardization.

International Standards are drafted in accordance with the rules given in the ISO/IEC Directives, Part 2.

The main task of technical committees is to prepare International Standards. Draft International Standards adopted by the technical committees are circulated to the member bodies for voting. Publication as an International Standard requires approval by at least 75 % of the member bodies casting a vote.

Attention is drawn to the possibility that some of the elements of this document may be the subject of patent rights. ISO shall not be held responsible for identifying any or all such patent rights.

ISO 17636-2 was prepared by the European Committee for Standardization (CEN) in collaboration with ISO Technical Committee TC 44, *Welding and allied processes*, Subcommittee SC 5, *Testing and inspection of welds* in accordance with the Agreement on technical cooperation between ISO and CEN (Vienna Agreement).

This first edition, together with ISO 17636-1, cancels and replaces ISO 17636:2003, of which it constitutes a technical revision.

ISO 17636 consists of the following parts, under the general title *Non-destructive testing of welds — Radiographic testing*:

- *Part 1: X- and gamma-ray techniques with film*
- *Part 2: X- and gamma-ray techniques with digital detectors*

The main changes are that:

- the normative references have been updated;
- the document has been divided into two parts — this part of ISO 17636 is applicable to radiographic testing with digital detectors;
- X-ray devices up to 1 000 kV have been included;
- Annex C on determination of basic spatial resolution has been added;
- Annex D on determination of minimum grey values for CR practice has been introduced;
- Annex E with general remarks on grey values has been added;
- the text has been editorially revised.

Requests for official interpretations of any aspect of this part of ISO 17636 should be directed to the Secretariat of ISO/TC 44/SC 5 via your national standards body. A complete listing of these bodies can be found at www.iso.org.

Introduction

This International Standard specifies fundamental techniques of radiography with the object of enabling satisfactory and repeatable results to be obtained economically. The techniques are based on generally recognized practice and fundamental theory of the subject, inspection of fusion welded joints with digital radiographic detectors.

Digital detectors provide a digital grey value image which can be viewed and evaluated with a computer only. The practice describes the recommended procedure for detector selection and radiographic practice. Selection of computer, software, monitor, printer and viewing conditions are important but are not the main focus of this part of ISO 17636.

The procedure specified in this part of ISO 17636 provides the minimum requirements and practice which permits exposure and acquisition of digital radiographs with equivalent sensitivity for detection of imperfections as film radiography, specified in ISO 17636-1.

Non-destructive testing of welds — Radiographic testing —

Part 2: X- and gamma-ray techniques with digital detectors

1 Scope

This part of ISO 17636 specifies fundamental techniques of digital radiography with the object of enabling satisfactory and repeatable results to be obtained economically. The techniques are based on generally recognized practice and fundamental theory of the subject.

This part of ISO 17636 applies to the digital radiographic examination of fusion welded joints in metallic materials. It applies to the joints of plates and pipes. Besides its conventional meaning, “pipe”, as used in this International Standard, covers other cylindrical bodies such as tubes, penstocks, boiler drums, and pressure vessels.

NOTE This part of ISO 17636 complies with EN 14784-2.[6]

This part of ISO 17636 specifies the requirements for digital radiographic X- and gamma-ray testing by either computed radiography (CR) or radiography with digital detector arrays (DDA) of the welded joints of metallic plates and tubes for the detection of imperfections.

Digital detectors provide a digital grey value (GV) image which can be viewed and evaluated using a computer. This part of ISO 17636 specifies the recommended procedure for detector selection and radiographic practice. Selection of computer, software, monitor, printer and viewing conditions are important, but are not the main focus of this part of ISO 17636. The procedure specified in this part of ISO 17636 provides the minimum requirements for radiographic practice which permit exposure and acquisition of digital radiographs with equivalent sensitivity for detection of imperfections as film radiography, as specified in ISO 17636-1.

This part of ISO 17636 does not specify acceptance levels for any of the indications found on the digital radiographs.

If contracting parties apply lower test criteria, it is possible that the quality achieved is significantly lower than when this part of ISO 17636 is strictly applied.

2 Normative references

The following referenced documents are indispensable for the application of this document. For dated references, only the edition cited applies. For undated references, the latest edition of the referenced document (including any amendments) applies.

ISO 5576, *Non-destructive testing — Industrial X-ray and gamma-ray radiology — Vocabulary*

ISO 9712, *Non-destructive testing — Qualification and certification of NDT personnel*

ISO 16371-1:2011, *Non-destructive testing — Industrial computed radiography with storage phosphor imaging plates — Part 1: Classification of systems*

ISO 17636-2:2013(E)

ISO 19232-1, *Non-destructive testing — Image quality of radiographs — Part 1: Image quality indicators (wire type) — Determination of image quality value*

ISO 19232-2, *Non-destructive testing — Image quality of radiographs — Part 2: Image quality indicators (step/hole type) — Determination of image quality value*

ISO 19232-4, *Non-destructive testing — Image quality of radiographs — Part 4: Experimental evaluation of image quality values and image quality tables*

ISO 19232-5, *Non-destructive testing — Image quality of radiographs — Part 5: Image quality indicators (duplex wire type) — Determination of image unsharpness value*

EN 12543 (all parts), *Non-destructive testing — Characteristics of focal spots in industrial X-ray systems for use in non-destructive testing*

EN 12679, *Non-destructive testing — Determination of the size of industrial radiographic sources — Radiographic method*

3 Terms and definitions

For the purposes of this document, the terms and definitions given in ISO 5576 and the following apply.

3.1
computed radiography
CR
storage phosphor imaging plate system
complete system comprising a storage phosphor imaging plate (IP) and a corresponding read-out unit (scanner or reader), which converts the information from the IP into a digital image

3.2
storage phosphor imaging plate
IP
photostimulable luminescent material capable of storing a latent radiographic image of a material being examined and, upon stimulation by a source of red light of appropriate wavelength, generates luminescence proportional to radiation absorbed

NOTE When performing computed radiography, an IP is used in lieu of a film. When establishing techniques related to source size or focal geometries, the IP is referred to as a detector, i.e. source-to-detector distance (SDD).

3.3
digital detector array system
DDA system
electronic device converting ionizing or penetrating radiation into a discrete array of analogue signals which are subsequently digitized and transferred to a computer for display as a digital image corresponding to the radiologic energy pattern imparted upon the input region of the device

3.4
structure noise of imaging plate
structure noise of IP
structure due to inhomogeneities in the sensitive layer (graininess) and surface of an imaging plate

NOTE 1 After scanning of the exposed imaging plate, the inhomogeneities appear as overlaid fixed pattern noise in the digital image.

NOTE 2 This noise limits the maximum achievable image quality of digital CR images and can be compared with the graininess in film images.

3.5**structure noise of digital detector array****structure noise of DDA**

structure due to different properties of detector elements (pixels)

NOTE After read-out of the exposed uncalibrated DDA, the inhomogeneities of the DDA appear as overlaid fixed pattern noise in the digital image. Therefore, all DDAs require, after read-out, a software based calibration (software and guidelines are provided by the manufacturer). A suitable calibration procedure reduces the structure noise.

3.6**grey value****GV**

numeric value of a pixel in a digital image

NOTE This is typically interchangeable with the terms pixel value, detector response, analogue-to-digital unit, and detector signal.

3.7**linearized grey value****GV_{lin}**

numeric value of a pixel which is directly proportional to the detector exposure dose, having a value of zero if the detector was not exposed

NOTE This is typically interchangeable with the terms linearized pixel value, and linearized detector signal.

3.8**basic spatial resolution of a digital detector****SR_b^{detector}**

corresponds to half of the measured detector unsharpness in a digital image and corresponds to the effective pixel size and indicates the smallest geometrical detail, which can be resolved with a digital detector at magnification equal to one

NOTE 1 For this measurement, the duplex wire IQI is placed directly on the digital detector array or imaging plate.

NOTE 2 The measurement of unsharpness is described in ISO 19232-5, see also ASTM E2736^[13] and ASTM E1000.^[8]

3.9**basic spatial resolution of a digital image****SR_b^{image}**

corresponds to half of the measured image unsharpness in a digital image and corresponds to the effective pixel size and indicates the smallest geometrical detail, which can be resolved in a digital image

NOTE 1 For this measurement, the duplex wire IQI is placed directly on the object (source side).

NOTE 2 The measurement of unsharpness is described in ISO 19232-5, see also ASTM E2736,^[13] and ASTM E1000.^[8]

3.10**signal-to-noise ratio****SNR**

ratio of mean value of the linearized grey values to the standard deviation of the linearized grey values (noise) in a given region of interest in a digital image

ISO 17636-2:2013(E)**3.11****normalized signal-to-noise ratio****SNR_N**

signal-to-noise ratio, SNR, normalized by the basic spatial resolution, SR_b, as measured directly in the digital image and/or calculated from the measured SNR, SNR_{measured}, by

$$\text{SNR}_N = \text{SNR}_{\text{measured}} \frac{88,6 \mu\text{m}}{\text{SR}_b}$$

3.12**contrast-to-noise ratio****CNR**

ratio of the difference of the mean signal levels between two image areas to the averaged standard deviation of the signal levels

NOTE The contrast-to-noise ratio describes a component of image quality and depends approximately on the product of radiographic attenuation coefficient and SNR. In addition to adequate CNR, it is also necessary for a digital radiograph to possess adequate unsharpness or basic spatial resolution to resolve desired features of interest.

3.13**normalized contrast-to-noise ratio****CNR_N**

contrast-to-noise ratio, CNR, normalized by the basic spatial resolution, SR_b, as measured directly in the digital image and/or calculated from the measured CNR, i.e.

$$\text{CNR}_N = \text{CNR} \times \frac{88,6 \mu\text{m}}{\text{SR}_b}$$

3.14**aliasing**

artefacts that appear in an image when the spatial frequency of the input is higher than the output is capable of reproducing

NOTE Aliasing often appears as jagged or stepped sections in a line or as moiré patterns.

3.15**cluster kernel pixel****CKP**

bad pixel which does not have five or more good neighbourhood pixels

NOTE See ASTM E2597[11] for details on bad pixels and CKP.

3.16**nominal thickness**

t

thickness of the parent material only where manufacturing tolerances do not have to be taken into account

3.17**penetration thickness change**

Δt

change of penetrated thickness relative to the nominal thickness due to beam angle

3.18**penetrated thickness**

w

thickness of material in the direction of the radiation beam calculated on the basis of the nominal thicknesses of all penetrated walls

3.19**object-to-detector distance***b*

largest (maximum) distance between the radiation side of the radiographed part of the test object and the sensitive layer of the detector along the central axis of the radiation beam

3.20**source size***d*

size of the radiation source or focal spot size

NOTE See EN 12679 or EN 12543.

3.21**source-to-detector distance****SDD**

distance between the source of radiation and the detector, measured in the direction of the beam

NOTE $SDD = f + b$

where

f source-to-object distance

b object-to-detector distance

3.22**source-to-object distance***f*

distance between the source of radiation and the source side of the test object, most distant from the detector, measured along the central axis of the radiation beam

3.23**external diameter***D_e*

nominal external diameter of the pipe

3.24**geometric magnification***v*

ratio of source-to-detector distance SDD to source-to-object distance, *f*

4 Symbols and abbreviated terms

For the purposes of this standard, the symbols given in Table 1 apply.

Table 1 — Symbols and abbreviated terms

Symbol	Term
<i>b</i>	object-to-detector distance
<i>b'</i>	object-to-detector distance perpendicular to test object
<i>d</i>	source size, focal spot size
<i>D_e</i>	external diameter
<i>f</i>	source-to-object distance
<i>f'</i>	source-to-object distance perpendicular to test object
SNR	signal-to-noise ratio

ISO 17636-2:2013(E)

SNR_N	normalized signal-to-noise ratio
t	nominal thickness
Δt	penetration thickness change
u_G	geometric unsharpness
u_i	inherent unsharpness of the detector system, excluding any geometric unsharpness, measured from the digital image with a duplex wire IQI adjacent to the detector
u_{im}	required image unsharpness measured in the digital image at the object plane with a duplex wire IQI
u_T	total image unsharpness, including geometric unsharpness, measured in the digital image at the detector plane with a duplex wire IQI at the object plane
v	geometric magnification
w	penetrated thickness
CKP	cluster kernel pixel
CNR	contrast-to-noise ratio
CNR_N	normalized contrast-to-noise ratio
CR	computed radiography
D	detector
DDA	digital detector array
IP	storage phosphor imaging plate
IQI	image quality indicator
S	radiation source
SDD	source-to detector-distance
SR_b	basic spatial resolution as determined with a duplex wire IQI adjacent to the detector
SR_b^{detector}	basic spatial resolution of a digital detector
SR_b^{image}	basic spatial resolution as determined with a duplex wire IQI on the source side of the object

5 Classification of radiographic techniques and compensation principles**5.1 Classification**

The radiographic techniques are divided into two classes:

- Class A: basic techniques;
- Class B: improved techniques.

Class B techniques are used when class A might be insufficiently sensitive.

Better techniques compared to class B are possible and may be agreed between the contracting parties by specification of all appropriate test parameters.

The choice of digital radiographic technique shall be agreed between the contracting parties.

Nevertheless, the visibility of flaws using film radiography or digital radiography is equivalent when using class A and class B techniques, respectively. The visibility shall be proven by the use of IQIs according to ISO 19232-1 or ISO 19232-2 and ISO 19232-5.

If, for technical reasons, it is not possible to meet one of the conditions specified for class B, such as the type of radiation source or the source-to-object distance, f , it may be agreed between the contracting parties that

the condition selected may be that specified for class A. The loss of sensitivity shall be compensated by an increase of minimum grey value and SNR_N for CR or SNR_N for the DDA-technique (recommended increase of SNR_N by a factor $>1,4$). Because of the better sensitivity compared to class A, the test specimen may be regarded as being examined to class B, if the correct IQI sensitivity is achieved. This does not apply if the special SDD reduction as described in 7.6 for test arrangements 7.1.4 and 7.1.5 are used.

5.2 Compensation principles, CP I, CP II or CP III

5.2.1 General. Three rules (see 5.2.2 to 5.2.4) are applied in this part of ISO 17636 for radiography with digital detectors to achieve a sufficient contrast sensitivity.

Application of these rules requires the achievement of a minimum contrast-to-noise ratio, CNR_N , normalized to the detector basic spatial resolution per detectable material thickness difference Δw . If the required normalized contrast-to-noise ratio (CNR_N per Δw) cannot be achieved due to an insufficient value of one of the following parameters, this can be compensated by an increase in the SNR.

5.2.2 CP I. Compensation for reduced contrast (e.g. by increased tube voltage) by increased SNR (e.g. by increased tube current or exposure time).

5.2.3 CP II. Compensation for insufficient detector sharpness (the value of SR_b higher than specified) by increased SNR (increase in the single IQI wire or step hole value for each missing duplex wire pair value).

5.2.4 CP III. Compensation for increased local interpolation unsharpness, due to bad pixel correction for DDAs, by increased SNR.

5.2.5 Theoretical background. These compensation principles are based on the following approximation for small flaw sizes ($\Delta w \ll w$):

$$\frac{CNR_N}{\Delta w} = c \frac{\mu_{\text{eff}} SNR}{SR_b}$$

where

c is a constant;

μ_{eff} is the effective attenuation coefficient, which is equivalent to the specific material contrast;

CNR_N is the normalized CNR, as measured in the digital image.

6 General preparations and requirements

6.1 Protection against ionizing radiation

WARNING — Exposure of any part of the human body to X-rays or gamma-rays can be highly injurious to health. Wherever X-ray equipment or radioactive sources are in use, appropriate legal requirements shall be applied.

Local or national or international safety precautions when using ionizing radiation shall be strictly applied.

6.2 Surface preparation and stage of manufacture

In general, surface preparation is not necessary, but where surface imperfections or coatings can cause difficulty in detecting defects, the surface shall be ground smooth or the coatings shall be removed.

Unless otherwise specified, digital radiography shall be carried out after the final stage of manufacture, e.g. after grinding or heat treatment.

ISO 17636-2:2013(E)

6.3 Location of the weld in the radiograph

Where the digital radiograph does not show the weld, high density markers shall be placed on either side of the weld.

6.4 Identification of radiographs

Symbols shall be affixed to each section of the object being digitally radiographed. The images of these symbols shall appear in the digital radiograph outside the region of interest where possible and shall ensure unambiguous identification of the section.

6.5 Marking

Permanent markings on the object to be examined shall be made in order to accurately locate the position of each digital radiograph (e.g. zero point, direction, identification, measure).

Where the nature of the material and/or its service conditions do not permit permanent marking, the location may be recorded by means of accurate sketches or photographs.

6.6 Overlap of digital images

When digitally radiographing an area with two or more separate detectors (imaging plates), they shall overlap sufficiently to ensure that the complete region of interest is digitally radiographed. This shall be verified by a high density marker on the surface of the object which is to appear on each digital image. If the radiographs are taken sequentially, the high density marker shall be visible on each of the radiographs.

6.7 Types and positions of image quality indicators

The quality of image shall be verified by use of image quality indicators (IQIs) in accordance with ISO 19232-5 and ISO 19232-1 or ISO 19232-2.

Following the procedure outlined in Annex C, a reference image is required for the verification of the basic spatial resolution of the digital detector system. The basic spatial resolution or duplex wire value shall be determined to verify whether the system hardware meets the requirements specified as a function of the penetrated material thickness in Tables B.13 and B.14. In this case, the duplex wire IQI shall be positioned directly on the digital detector. The use of a duplex wire IQI (ISO 19232-5) for production radiographs is not compulsory. The requirement for using a duplex wire IQI additionally to a single wire IQI for production radiographs may be part of the agreement between the contracting parties. For use on production radiographs, the duplex wire IQI shall be positioned on the object. The measured basic spatial resolution of the digital image (SR_b^{image}) (see Annex C), shall not exceed the maximum values specified as a function of the penetrated material thickness (Tables B.13 or B.14). For single image inspection, the single wall thickness is taken as the penetrated material thickness. For double wall double image inspection (Figures 11 or 12), with the duplex wire on the source side of the pipe, the penetrated material thickness is taken as the pipe diameter for determination of the required basic spatial resolution (SR_b^{image}) from Tables B.13 and B.14. The basic spatial resolution of the detector (SR_b^{detector}) for double wall double image inspection shall correspond to the values of Tables B.13 and B.14 chosen on the basis of twice the nominal single wall thickness as the penetrated material thickness.

If the geometric magnification technique (see 7.7) is applied with $v > 1,2$, then the duplex wire IQI (ISO 19232-5) shall be used on all production radiographs.

The duplex wire IQI shall be positioned tilted by a few degrees (2° to 5°) to the digital rows or columns of the digital image. If the IQI is positioned at 45° to the digital lines or rows the obtained IQI number shall be reduced by one.

The contrast sensitivity of digital images shall be verified by use of IQIs, in accordance with the specific application as given in Tables B.1 to B.12 (see also ISO 19232-1 or ISO 19232-2).

The single wire or step hole IQIs used shall be placed preferably on the source side of the test object at the centre of the area of interest on the parent metal beside the weld. The IQI shall be in close contact with the surface of the object. Its location shall be in a section of uniform thickness characterized by a uniform grey value (mean) in the digital image.

According to the IQI type used, cases a) and b) shall be considered.

- a) When using a single wire IQI, the wires shall be directed perpendicular to the weld and its location shall ensure that at least 10 mm of the wire length shows in a section of uniform grey value or SNR_N , which is normally in the parent metal adjacent to the weld. For exposures in accordance with 7.1.6 and 7.1.7, the IQI can be placed with the wires across the pipe axis and they should not be projected into the image of the weld.
- b) When using a step hole IQI, it shall be placed in such a way that the hole number required is placed close to the weld.

For exposures in accordance with 7.1.6 and 7.1.7, the IQI type used can be placed either on the source or on the detector side. If the IQIs cannot be placed in accordance with the above conditions, the IQIs are placed on the detector side and the image quality shall be determined at least once from comparison exposure with one IQI placed at the source side and one at the detector side under the same conditions. If filters are used in front of the detector, the IQI shall be placed in front of the filter.

For double wall exposures, when the IQI is placed on the detector side, the above test is not necessary. In this case, refer to the correspondence tables (Tables B.9 to B.14).

Where the IQIs are placed on the detector side, the letter F shall be placed near the IQI and it shall be stated in the test report.

The identification numbers and, when used, the lead letter F, shall not be in the area of interest, except when geometric configuration makes it impractical.

If steps have been taken to guarantee that digital radiographs of similar test objects and regions are produced with identical exposure and processing techniques, and no differences in the image quality value are likely, the image quality need not be verified for every digital radiograph. The extent of image quality verification should be subject to agreement between the contracting parties.

For exposures of pipes with diameter 200 mm and above with the source centrally located at least three IQIs should be placed equally spaced at the circumference. The IQI images are then considered representative for the whole circumference.

6.8 Minimum image quality values

Tables B.1 to B.14 show the minimum quality values for metallic materials. For other materials these requirements or corresponding requirements may be agreed upon by contracting parties. The requirements shall be determined in accordance with ISO 19232-4.

In the case where Ir 192 or Se 75 sources are used, IQI values worse than the ones listed in Tables B.1 to B.12 may be accepted by agreement of contracting parties as follows:

Double wall, double image techniques, both class A and B ($w = 2t$):

- $10 \text{ mm} < w \leq 25 \text{ mm}$ 1 wire or step hole value less for Ir 192;
- $5 \text{ mm} < w \leq 12 \text{ mm}$ 1 wire or step hole value less for Se 75.

ISO 17636-2:2013(E)

Single wall single image and double wall single image techniques, class A:

- $10 \text{ mm} < w \leq 24 \text{ mm}$ 2 wire or step hole values less for Ir 192;
- $24 \text{ mm} < w \leq 30 \text{ mm}$ 1 wire or step hole value less for Ir 192;
- $5 \text{ mm} < w \leq 24 \text{ mm}$ 1 wire or step hole value less for Se 75.

Single wall single image and double wall single image techniques, class B:

- $10 \text{ mm} < w \leq 40 \text{ mm}$ 1 wire or step hole value less for Ir 192;
- $5 \text{ mm} < w \leq 20 \text{ mm}$ 1 wire or step hole value less for Se 75.

6.9 Personnel qualification

Personnel performing non-destructive examination in accordance with this part of ISO 17636 shall be qualified in accordance with ISO 9712 or equivalent to an appropriate level in the relevant industrial sector. The personnel shall be able to prove they have undergone additional training and qualification in digital industrial radiology.

7 Recommended techniques for making digital radiographs

NOTE Unless otherwise explained, definitions of the symbols used in Figures 1 to 21 can be found in Clause 4.

7.1 Test arrangements**7.1.1 General**

Normally digital radiographic techniques in accordance with 7.1.2 to 7.1.9 shall be used.

The elliptical technique (double wall and double image) in accordance with Figure 11 should not be used for external diameter $D_e > 100 \text{ mm}$ or wall thickness $t > 8 \text{ mm}$ or weld width $> D_e / 4$. Two 90° displaced images are sufficient if $t / D_e < 0,12$, otherwise three images are needed. The distance between the two projected weld images shall be about one weld width.

When it is difficult to carry out an elliptical examination for $D_e \leq 100 \text{ mm}$, the perpendicular technique in accordance with 7.1.7 may be used (see Figure 12). In this case, three exposures 120° or 60° apart are required.

For test arrangements in accordance with Figures 11, 13, and 14, the inclination of the beam shall be kept as small as possible and be such as to prevent superimposition of the two images. The source-to-object distance, f , shall be kept as small as possible for the technique shown in Figure 13, in accordance with 7.6. The IQI shall be placed close to the detector with a lead letter F.

Other digital radiographic techniques may be agreed by the contracting parties when it is useful, e.g. for reasons such as the geometry of the piece or differences in material thickness. In 7.1.9, an example of such a case is presented. Additionally, thickness compensation with the same material may be applied.

NOTE In Annex A the minimum number of digital radiographs necessary is given in order to obtain an acceptable radiographic coverage of the total circumference of a butt weld in pipe.

If the geometric magnification technique is not used, the detector shall be placed as close to the object as possible.

If flexible detectors are not applicable and rigid cassettes or planar digital detector arrays are used as shown in Figures 2 b), 8 b), 13 b), and 14 b), the source-to-detector distance SDD shall be calculated from the wall thickness t and the largest distance of the detector to the source side surface of the object b and the focal spot size or source size d , as specified in 7.6, Formulae (3) and (4).

7.1.2 Radiation source located in front of the object and with the detector at the opposite side (see Figure 1)

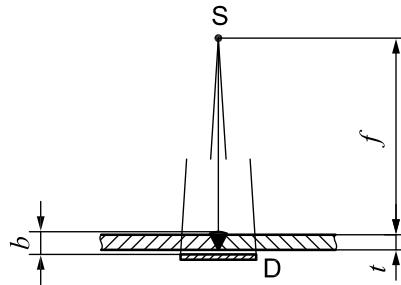
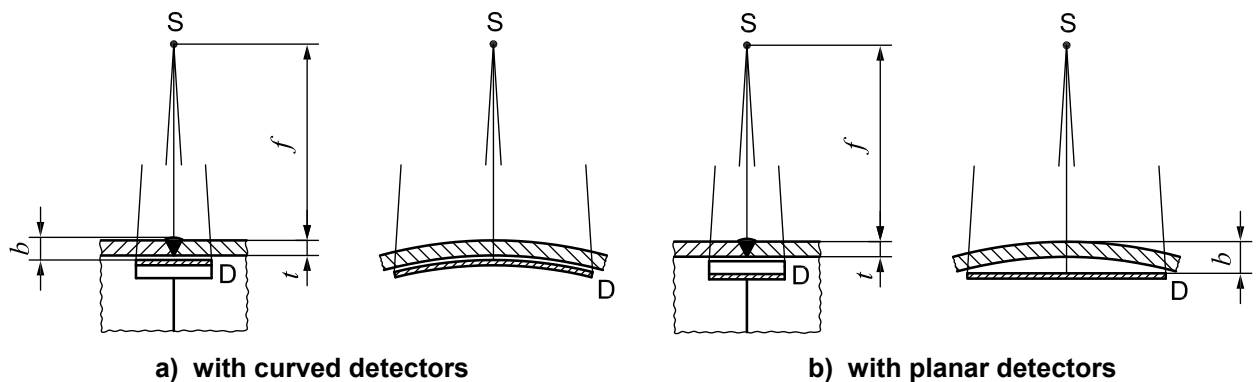

Figure 1 — Test arrangement for plane welds and single wall penetration

7.1.3 Radiation source located outside the object and detector inside (see Figures 2 to 4)



a) with curved detectors

b) with planar detectors

Figure 2 — Test arrangement for single wall penetration of curved objects

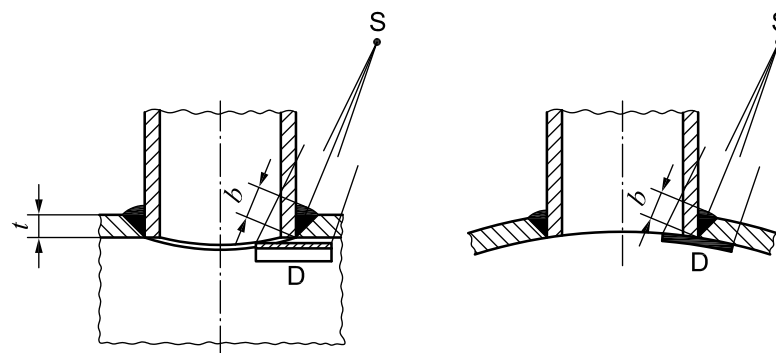

Figure 3 — Test arrangement for single-wall penetration of curved objects (set-in weld)

ISO 17636-2:2013(E)

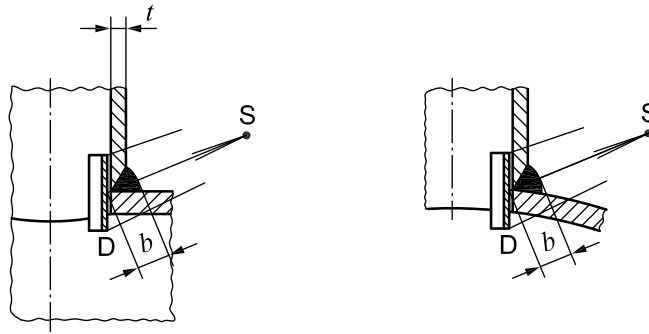

Figure 4 — Test arrangement for single wall penetration of curved objects (set-on weld)

7.1.4 Radiation source centrally located inside the object and with the detector outside (see Figures 5 to 7)

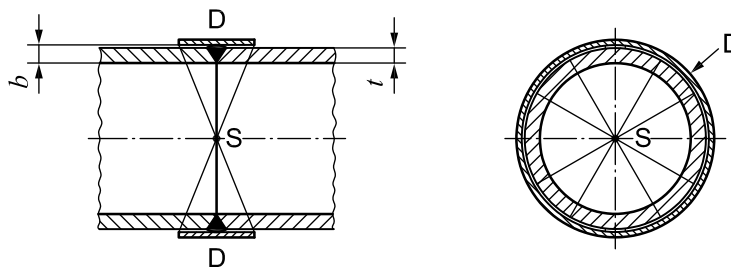

Figure 5 — Test arrangement for single wall penetration of curved objects, planar detectors not applicable

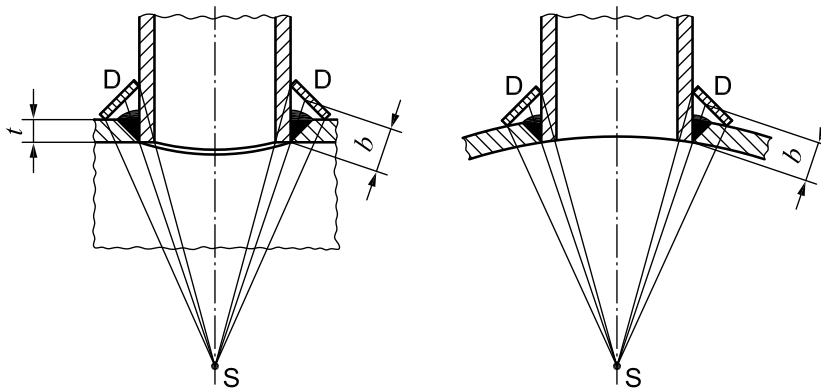

Figure 6 — Test arrangement for single wall penetration of curved objects (set-in weld)

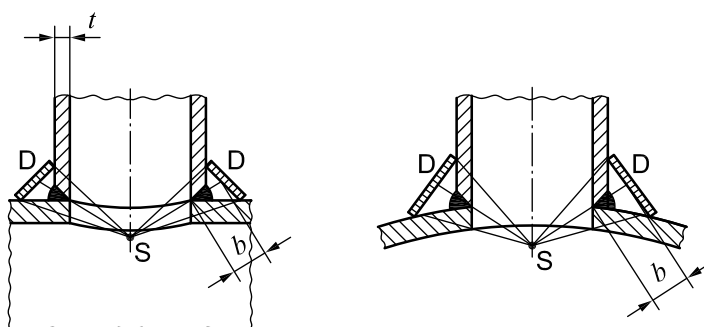

Figure 7 — Test arrangement for single wall penetration of curved objects (set-on weld)

7.1.5 Radiation source located off-centre inside the object and detector outside (see Figures 8 to 10)

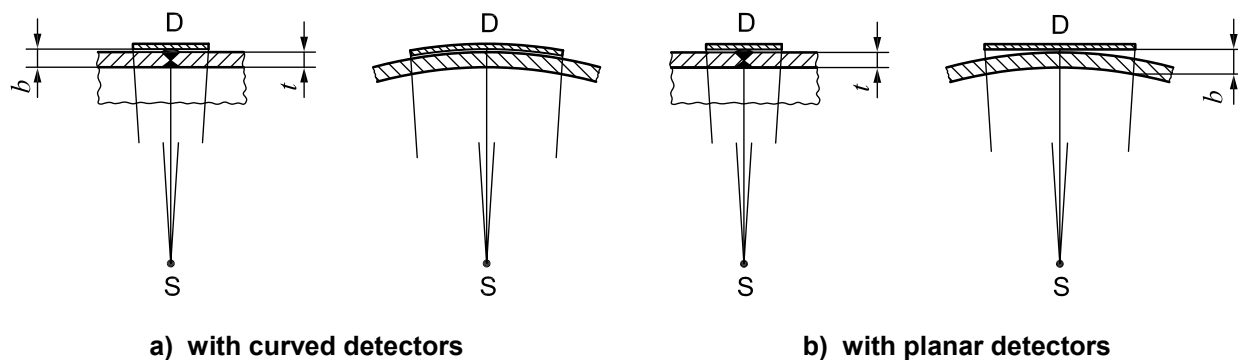

Figure 8 — Test arrangement for single wall penetration of curved objects

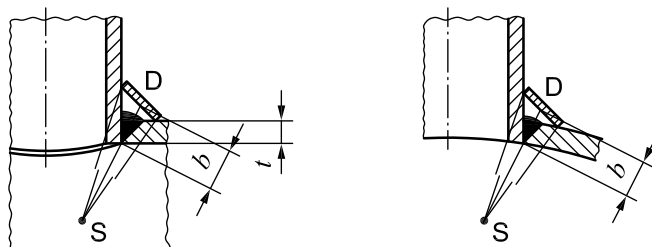

Figure 9 — Test arrangement for single wall penetration of curved object (set-in weld)

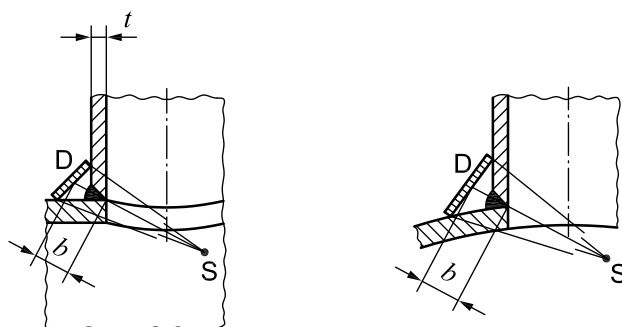

Figure 10 — Test arrangement for single wall penetration of curved objects (set-on weld)

ISO 17636-2:2013(E)

7.1.6 Elliptic technique (see Figure 11)

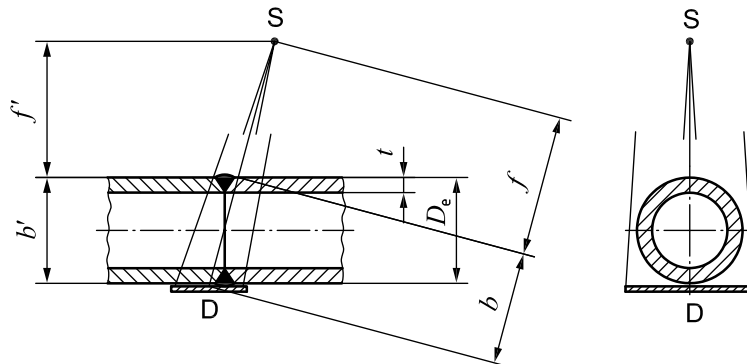

Figure 11 — Test arrangement for double wall penetration double image of curved objects for evaluation of both walls (source and detector outside of the test object)

NOTE The source-to-object distance can be approximated by the perpendicular distance f' , calculated from b' .

7.1.7 Perpendicular technique (see Figure 12)

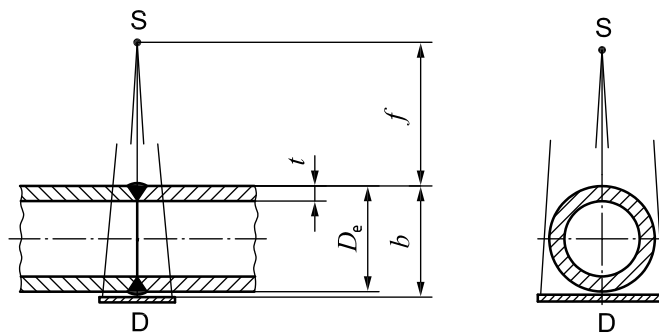

Figure 12 — Test arrangement for double wall penetration double image of curved objects for evaluation of both walls (source and detector outside of the test object)

7.1.8 Radiation source located outside the object and detector on the other side (see Figures 13 to 18)

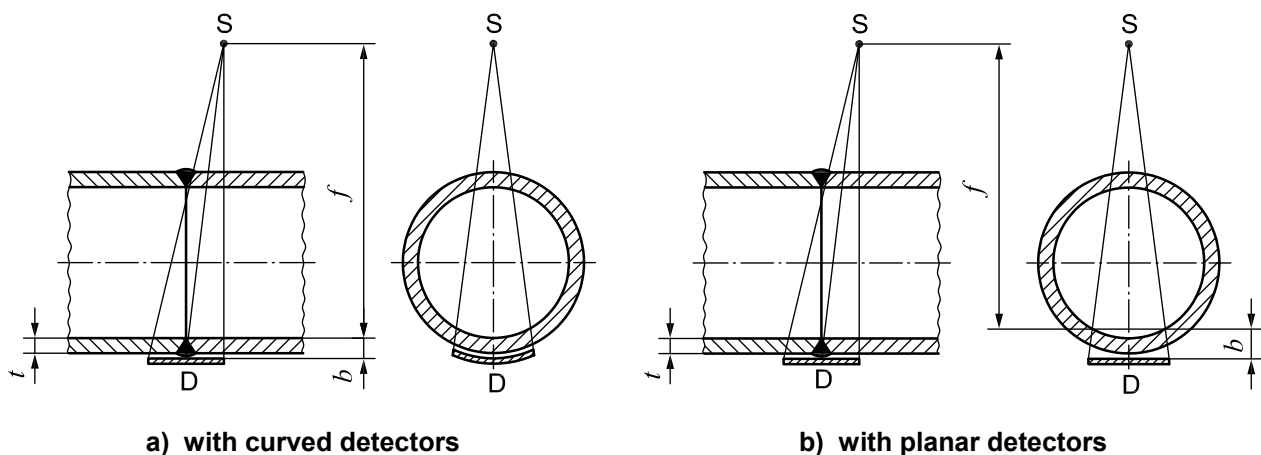

Figure 13 — Test arrangement for double wall penetration single image of curved objects for evaluation of the wall next to the detector with the IQI placed close to the detector

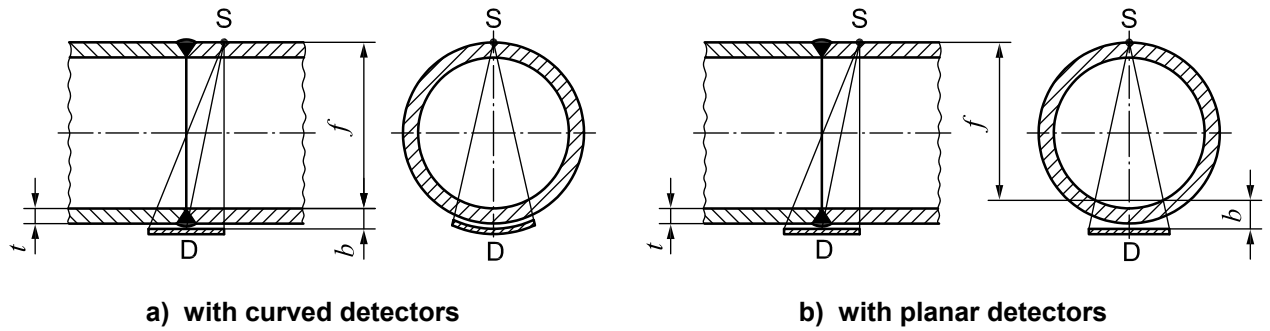

Figure 14 — Test arrangement for double wall penetration single image

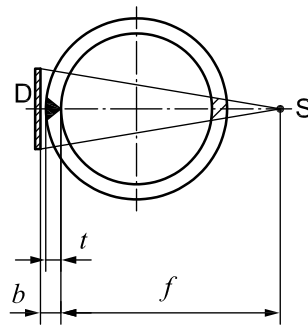

Figure 15 — Test arrangement for double wall penetration single image of longitudinal welds

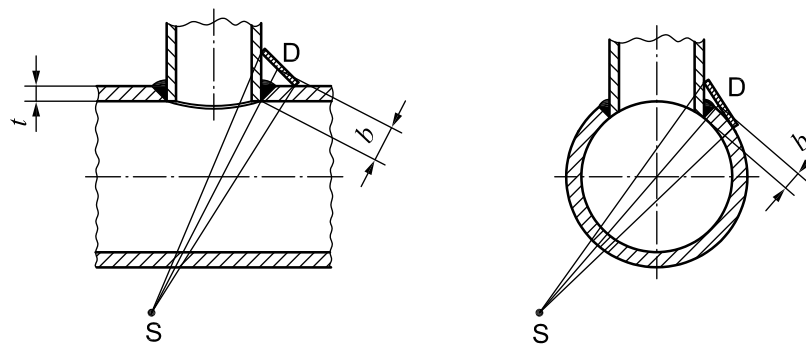

Figure 16 — Test arrangement for double wall penetration single image of curved objects for evaluation of the wall next to the detector

ISO 17636-2:2013(E)



Key

1 compensating edge

a) Test arrangement without compensating edge b) Test arrangement with compensating edge

Figure 17 —Test arrangement for penetration of fillet welds

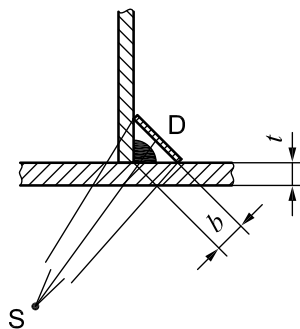

Figure 18 —Test arrangement for penetration of fillet welds

7.1.9 Technique for different material thicknesses (see Figure 19)

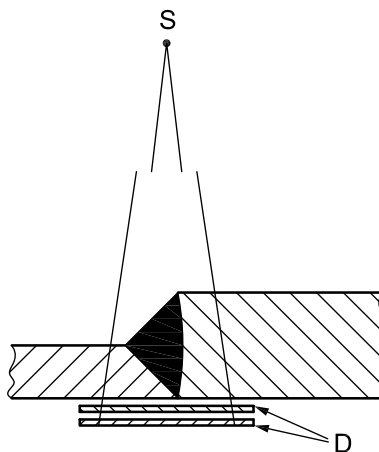

Figure 19 —Multi-detector technique, applicable for CR

7.2 Choice of tube voltage and radiation source

7.2.1 X-ray devices up to 1 000 kV

To maintain good flaw sensitivity, the X-ray tube voltage should be as low as possible and the SNR_N in the digital image should be as high as possible. Recommended maximum values of X-ray tube voltage versus penetrated thickness are given in Figure 20. These maximum values are best practice values for film radiography.

After accurate calibration, DDAs can provide sufficient image quality at significantly higher voltages than those shown in Figure 20.

Imaging plates with high structure noise in the sensitive IP layer (coarse grained) should be applied with about 20 % less X-ray voltage than indicated in Figure 20 for class B testing. High definition imaging plates, which are exposed similarly to X-ray films and having low structure noise (fine grained) can be exposed with the X-ray voltages of Figure 20 or significantly higher if the SNR_N is sufficiently increased.

NOTE CP I:

- an improvement in contrast sensitivity can be achieved by an increase in contrast at constant SNR_N [by reduction of tube voltage and compensation by higher exposure (e.g. milliampère · minutes)]; or
- improvement in contrast sensitivity by an increase in SNR_N [by higher exposure (e.g. milliampère · minutes)] at constant contrast (constant kilovolt level);
- increased tube voltage [at a constant exposure (e.g. milliampère minutes)] reduces the contrast and increases the SNR_N . The contrast sensitivity improves if the increase in SNR_N is higher than the contrast reduction due to the higher energy.

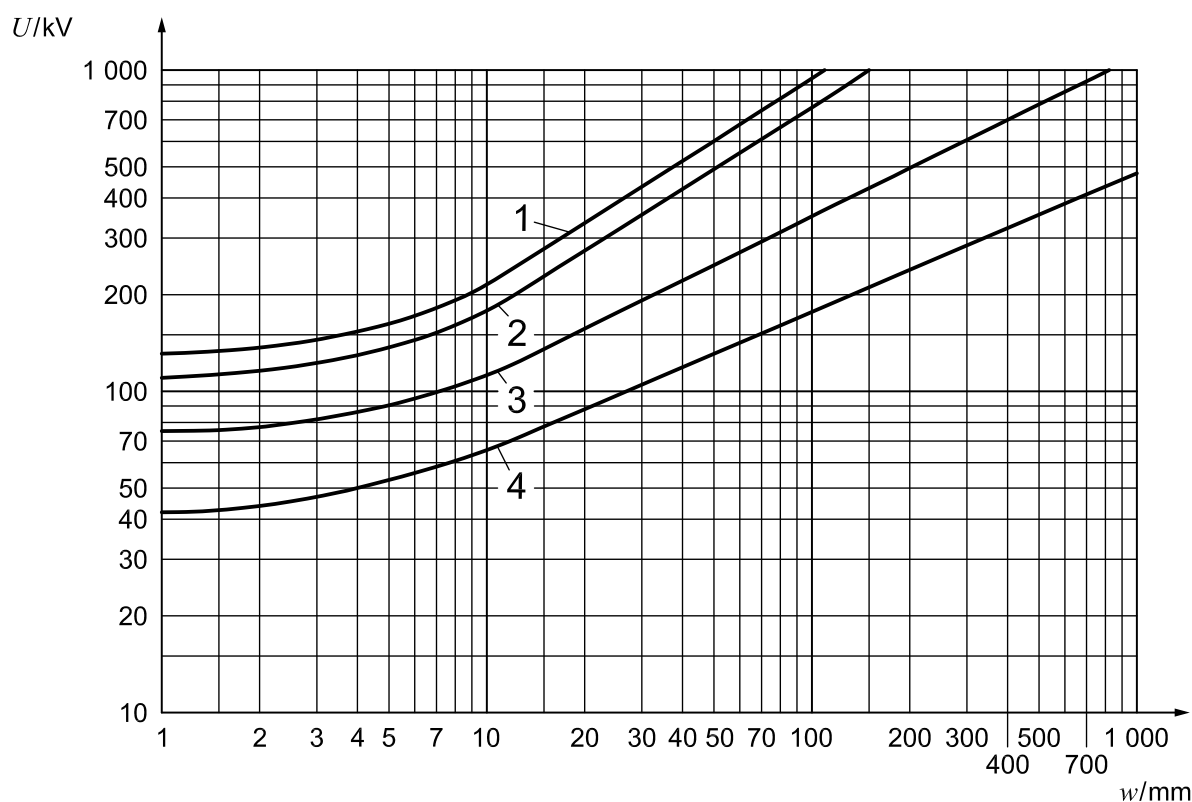

Key

U	X-ray voltage	1	copper and nickel and alloys
w	penetrated thickness	2	steel
		3	titanium and alloys
		4	aluminium and alloys

Figure 20 —X-ray voltage for X-ray devices up to 1 000 kV as a function of penetrated thickness and material

For some applications where there is a thickness change across the area of the object being radiographed, a modification of technique with a higher voltage may be used, but it should be noted that an excessively high tube voltage leads to a loss of defect detection sensitivity.

ISO 17636-2:2013(E)

7.2.2 Other radiation sources

The recommended penetrated thickness ranges for gamma-ray sources and X-ray equipment above 1 MeV are given in Table 2.

On thin steel specimens, gamma-rays from Se 75, Ir 192 and Co 60 sources do not produce digital radiographs having as good a defect detection sensitivity as X-rays used with appropriate technique parameters. However, because of the advantages of gamma-ray sources in handling and accessibility, Table 2 gives a range of thicknesses for which each of these gamma-ray sources may be used when the use of X-ray tubes is difficult.

By agreement between the contracting parties, the penetrated material thickness may be further reduced to 10 mm for Ir 192 and 5 mm for Se 75.

For certain applications, wider material thickness ranges may be permitted, if sufficient image quality can be achieved.

In cases where digital radiographs are produced by CR using gamma-rays, the total travel time to and from the source position shall not exceed 10 % of the total exposure time. Using DDAs, the capture time shall start after the source is in position and shall end before the source is moved back.

Table 2 — Penetrated thickness range for gamma-ray sources and X-ray equipment with energy above 1 MeV for steel, copper and nickel base alloys

Radiation source	Penetrated thickness w mm	
	Class A	Class B
Tm 170	$w \leq 5$	$w \leq 5$
Yb 169 ^a	$1 \leq w \leq 15$	$2 \leq w \leq 12$
Se 75 ^b	$10 \leq w \leq 40$	$14 \leq w \leq 40$
Ir 192	$20 \leq w \leq 100$	$20 \leq w \leq 90$
Co 60	$40 \leq w \leq 200$	$60 \leq w \leq 150$
X-ray equipment with energy from 1 MeV to 4 MeV	$30 \leq w \leq 200$	$50 \leq w \leq 180$
X-ray equipment with energy from 4 MeV to 12 MeV	$w \geq 50$	$w \geq 80$
X-ray equipment with energy above 12 MeV	$w \geq 80$	$w \geq 100$

^a For aluminium and titanium, the penetrated material thickness is $10 \text{ mm} \leq w \leq 70 \text{ mm}$ for class A and $25 \text{ mm} \leq w \leq 55 \text{ mm}$ for class B.

^b For aluminium and titanium, the penetrated material thickness is $35 \text{ mm} \leq w \leq 120 \text{ mm}$ for class A.

The maximum penetrated thicknesses as given in Table 2 may be exceeded if sufficient IQI sensitivity can be proven.

7.3 Detector systems and metal screens

7.3.1 Minimum normalized signal-to-noise ratio

For digital radiographic examination, minimum SNR_N values as given in Tables 3 and 4 or minimum grey values (CR only) shall be achieved. Annex D describes the procedure for measurement of SNR_N and provides a conversion table for users who prefer to use unnormalized measured SNR values instead of normalized SNR_N values.

Equivalent minimum grey values for CR may be used instead of minimum SNR_N values if they are determined by means of the procedure of Annex D for the IP used, the scanner used and its settings and the required SNR_N of Tables 3 and 4.

The SNR_N value shall be measured beside the weld near the wire or step hole IQIs in the thicker part of the parent material in a zone of homogeneous wall thickness and grey values. The grey values in CR (only) shall be measured in the region of interest in the weldment near the wire or step hole IQI. Since the roughness of the material influences image noise and SNR_N , the values in Table 3 are recommended values only. The minimum SNR_N values shall be increased by a factor of 1,4 in comparison to Tables 3 and 4 if the SNR_N measurement is performed adjacent to the weld in the heat-affected zone, except if the weld cap and root are flush with the parent material.

NOTE 1 In film radiography, the optical density is typically between 3,5 and 4 if measured in the heat-affected zone (HAZ)/parent material. This corresponds to a higher SNR_N by about 1,4 in comparison to the centre of the weld, which should have an optical density of 2 or higher. It is highly recommended that the SNR_N be measured in the heat-affected zone, because this is typically an area of constant grey level and enables accurate measurements of the SNR_N .

Annex D describes the method for determination of equivalent minimum grey values (for CR only) in lieu of the required SNR_N .

Annex D also provides a conversion table for users who prefer the measurement of unnormalized SNR instead of SNR_N . The minimum unnormalized SNR is determined from the SR_b of the detector and the required SNR_N values in Tables 3 and 4.

The user shall define minimum grey values or SNR_N or SNR values for CR (see Annex D) for acceptance of digital images. The user shall define minimum SNR_N or SNR values (see Annex D) for radiography with DDAs for acceptance of digital images in analogy to the minimum optical density for film radiography. If no special values are defined, the values of Tables 3 and 4 shall be achieved. The minimum SNR_N values are given in Tables 3 and 4 for different radiation sources and material thicknesses.

NOTE 2 For details of SNR_N measurement, see ISO 16371-1, ASTM E 2446^[10] (for CR) or ASTM E2597^[11] (for DDA) and Annex D.

7.3.2 Compensation principle II

If both IQI sensitivities (contrast sensitivity by single IQI wires or step holes on the one hand and spatial resolution of the detector by duplex wire IQIs on the other) of Table B.1 to Table B.14 cannot be achieved by the detector system and exposure conditions used, an increase in single IQI wire visibility or step hole visibility shall compensate for the exceeded unsharpness values (or exceeded SR_b values).

For example, if the required values of D12 and W16 (for 5 mm thickness, class B — Tables B.3 and B.14) are not achieved at the same time for a specific detector set-up, then the values D11 and W17 provide an equivalent detection sensitivity. The compensation shall be limited to a maximum increase of two single wires for two missing resolved duplex wire pairs. If the required flaw sensitivity can be demonstrated for the specific application, by agreement between the contracting parties, the compensation may be extended to a maximum of three single wires for three missing resolved duplex wire pairs.

For digital detectors (DDA), the contrast sensitivity depends on the used integration time and tube current (milliamperes) for acquisition of the radiographic images for a given distance and tube voltage, so the single wire or step hole IQI visibility can be increased by increased exposure time and/or tube current setting. This applies also for CR, but with a limitation due to the maximum achievable SNR_N due to the structure noise of the sensitive PSL layer of imaging plates. The maximum achievable SNR_N for DDA radiography is limited by the quality of the calibration procedure.

The SR_b of the detector is fixed by design and hardware parameters.

If the magnification technique is used, the SR_b shall be taken from the magnified image (SR_b of the image) and the duplex wire IQI measurement with the duplex wire IQI on the object (see 7.7).

ISO 17636-2:2013(E)

7.3.3 Metal screens for IPs and shielding

When using metal front screens, good contact between the sensitive detector layer and screens is required. This may be achieved either by using vacuum-packed IPs or by applying pressure. Lead screens not in intimate contact with the IPs may contribute to image unsharpness. The intensification obtained by use of lead screens in contact with imaging plates is significantly smaller than in film radiography.

Many IPs are very sensitive to low energy backscatter and X-ray fluorescence of back-shielding from lead. This effect contributes significantly to edge unsharpness and reduced CNR, and should be minimized. It is recommended that steel or copper shielding be used directly behind the IPs. Also a steel or copper shielding between a backscatter lead plate and the IP may improve the image quality. Modern cassette and detector designs may consider this effect and can be constructed in a way such that additional steel or copper shielding outside the cassette is not required.

NOTE Due to the protection layer between the lead and the sensitive layer of an IP, the effect of intensification by electrons is considerably reduced and appears at higher energies. Depending on the radiation energy and protection layer design, the effect of intensification amounts to between 20 % and 100 % only (compared to no screen) at typical X-ray energies.

The small intensification effect generated by a lead screen in contact with an IP can be compensated for by increased exposure time or milliamperè·minutes, if no lead screens are used. Since lead screens in contact with IPs may generate scratches on IPs, if not carefully separated for the scan process, lead screens should be used for intermediate filtering of scattered radiation outside of cassettes. No intermediate filtering is recommended for inspecting steel specimen having a thickness < 12 mm.

Tables 3 and 4 show the recommended screen materials and thicknesses for different radiation sources. Other screen thicknesses may be also agreed between the contracting parties provided the required image quality is achieved. The usage of metal screens is recommended in front of IPs, and they may also reduce the influence of scattered radiation when used with DDAs.

7.4 Alignment of beam

The beam of radiation shall be directed to the centre of the area being examined and should be perpendicular to the object surface at that point, except when it can be demonstrated that certain imperfections are best revealed by a different alignment of the beam. In this case, an appropriate alignment of the beam can be permitted. Other ways of digital radiographing may be agreed between the contracting parties.

EXAMPLE For better detection of lack of side wall fusion, the beam direction should be aligned with the weld preparation angles.

7.5 Reduction of scattered radiation

7.5.1 Metal filters and collimators

In order to reduce the effect of scattered radiation, direct radiation shall be collimated as much as possible to the section under examination.

With Se 75, Ir 192, and Co 60 radiation sources or X-ray sources above 1 MW, or in the case of edge scatter, a sheet of lead can be used as a filter of low energy scattered radiation between the object and the cassette or DDA. The thickness of this sheet is 0,5 mm to 2 mm in accordance with the penetrated thickness. Other materials than lead, e.g. tin, copper or steel, can also be used as a filter. A thin steel or copper screen should be positioned between the lead sheet and the detector.

Table 3 — Minimum SNR_N values (CR and DDA) and metal front screens (screens for CR only) for digital radiography of steels, copper and nickel based alloys

Radiation source	Penetrated material thickness <i>w</i> mm	Minimum SNR _N ^c		Type and thickness of metal front screens mm
		Class A	Class B	
X-ray potentials ≤50 kV		100	150	None
X-ray potentials ^d >50 kV to 150 kV		70	120	0 to 0,1 (Pb)
X-ray potentials ^d >150 kV to 250 kV		70	100	0 to 0,1 (Pb)
X-ray potentials ^d >250 kV to 350 kV	≤50	70	100	0 to 0,3 (Pb)
	>50	70	70	0 to 0,3 (Pb)
X-ray potentials ^d >350 kV to 1 000 kV	≤50	70	100	0 to 0,3 (Pb)
	>50	70	70	0 to 0,3 (Pb)
Yb 169 ^d	≤5	70	120	0 to 0,1 (Pb)
	>5	70	100	0 to 0,1 (Pb)
Ir 192 ^d , Se 75 ^d	≤50	70	100	0 to 0,3 (Pb)
	>50	70	70	0,1 to 0,4 (Pb)
Co 60 ^{a, b} X-ray potentials ^{a, b} >1 to 5 MV	≤100	70	100	0,3 to 0,8 (Fe or Cu) + 0,6 to 2 (Pb)
	>100	70	70	0,3 to 0,8 (Fe or Cu) + 0,6 to 2 (Pb)
X-ray potentials ^{a, b} >5 MV	≤100	70	100	0,6 to 4 (Fe, Cu or Pb)
	>100	70	70	0,6 to 4 (Fe, Cu or Pb)

^a In the case of multiple screens (Fe+Pb), the steel screen shall be located between the IP and the lead screen.

^b Instead of Fe or Fe+Pb also copper, tantalum or tungsten screens may be used if the image quality can be proven.

^c If the SNR_N is measured in the HAZ/parent material these values shall be multiplied by 1,4, except if the weld cap and root are flush with the parent material.

^d Pb screens may be replaced completely or partially by Fe or Cu screens. The equivalent thickness for Fe or Cu is three times the Pb thickness.

Table 4 — Minimum SNR_N values (CR and DDA) and metal front screens (screens for CR only) for the digital radiography of aluminium and titanium

Radiation source	Minimum SNR _N ^b		Type and thickness of metal front screens mm
	Class A	Class B	
X-ray potentials ≤ 150 kV	70	120	≤0,03 (Pb)
X-ray potentials > 150 kV to 250 kV	70	100	≤0,2 (Pb) ^a
X-ray potentials > 250 kV to 500 kV	70	100	≤0,2 (Pb) ^a
Yb 169	70	100	≤0,2 (Pb) ^a
Se 75	70	100	≤0,3 (Pb) ^a

^a Instead of 0,2 mm lead, a 0,1 mm screen with an additional filter of 0,1 mm may be used outside of the cassette.

^b If the SNR_N is measured in the HAZ/parent material these values shall be multiplied by 1,4, except if the weld cap and root are flush with the parent material.

ISO 17636-2:2013(E)**7.5.2 Interception of backscattered radiation**

The presence of backscattered radiation shall be checked for each new CR test arrangement by means of a lead letter B (with a minimum height of 10 mm and a minimum thickness of 1,5 mm) placed immediately behind each cassette. If the image of this symbol records as a lighter image on the digital radiograph (negative presentation, i.e. decreased linearized grey value), it shall be rejected. If the symbol is darker (increased linearized grey value), or invisible, the digital radiograph is acceptable and demonstrates good protection against backscattered radiation.

If necessary, the detector shall be shielded from backscattered radiation by a sheet of lead of at least 1 mm thickness or a sheet of tin of at least 1,5 mm thickness, placed behind the detector. An additional shielding of steel or copper (about 0,5 mm thickness) shall be applied between the lead shield and the detector to reduce the influence of lead X-ray fluorescence radiation. No lead screens shall be used in contact with the back side of the detector for radiation energies above 80 keV.

7.6 Source-to-object distance

The minimum source-to-object distance f_{\min} depends on the source size or focal spot size d and on the object-to-detector distance b . The source size or focal spot size d shall be in accordance with EN 12543 or EN 12679.

When the source size or focal spot size is defined by two dimensions, the larger shall be used.

For exposure geometries, except for those in Figures 2 b), 8 b), 13 b), and 14 b), the distance f shall, where practicable, be chosen so that the ratio of this distance to the source size or focal spot size, d , i.e. f/d , is not less than the values given by Formulae (1) and (2):

$$\frac{f}{d} \geq 7,5b^{2/3} \quad (1)$$

for class A and for class B

$$\frac{f}{d} \geq 15b^{2/3} \quad (2)$$

where b is expressed in millimetres.

If the distance b is less than $1,2t$, then the dimension b in Formulae (1) and (2) and Figure 21 shall be replaced by the nominal thickness, t .

For determination of the source-to-object distance, f_{\min} , the nomogram in Figure 21 may be used. This nomogram is based on Formulae (1) and (2).

For exposure geometries set on the basis of Figures 2 b), 8 b), 13 b), and 14 b), the distance f shall, where practicable, be chosen so that the ratio of this distance to the source size, d , i.e. f/d , is not below the values given by Formulae (3) and (4):

$$\frac{f}{d} \geq 7,5 \frac{b}{\sqrt[3]{t}} \quad (3)$$

for class A and for class B

$$\frac{f}{d} \geq 15 \frac{b}{\sqrt[3]{t}} \quad (4)$$

where

t is the nominal thickness, in millimetres, to inspect;

b is the object-to-detector distance, in millimetres.

In class A, if detection of planar imperfections is a requirement, the minimum source-to-object distance f_{\min} shall be the same as for class B in order to reduce the geometric unsharpness by a factor of 2.

In critical technical applications of crack-sensitive materials, more sensitive radiographic techniques than class B shall be used.

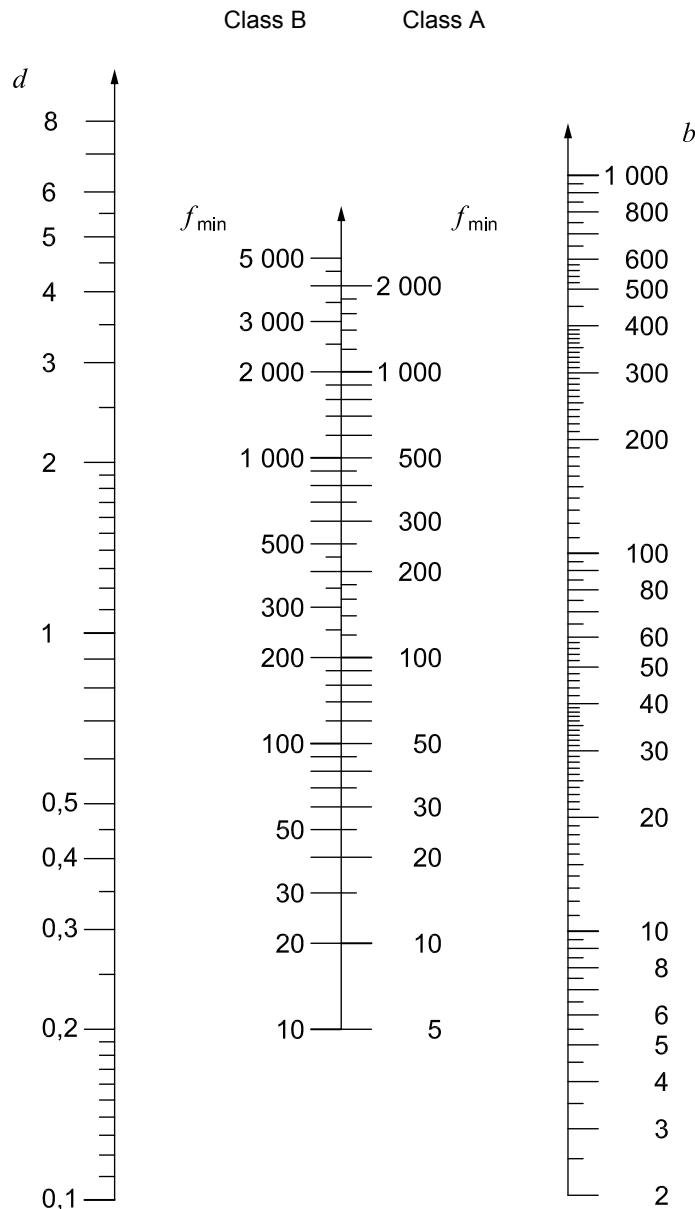

Figure 21 — Nomogram for the determination of minimum source-to-object distance f_{\min} in relation to object-to-detector distance b and the source size d

Both the inherent unsharpness ($u_i = 2SR_b^{\text{detector}}$) of a digital detector system and the geometric unsharpness (u_G) contribute to the total unsharpness (u_T) in the image if not corrected by means of geometric magnification:

ISO 17636-2:2013(E)

$$u_T = \sqrt{u_i^2 + u_G^2} \quad (5)$$

Therefore, it is recommended that the distance f_{\min} be increased to compensate for any additional unsharpness of the detector system.

If digital detectors are used, which have a greater inherent unsharpness than X-ray film, conditions a) and b) are recommended, if similar low total image unsharpness values, as defined by the procedure of ISO 17636-1 (film radiography), are to be achieved.

- a) Provided the object is in contact with the detector (this is not valid for the geometric magnification technique), then select digital detectors so that the detector basic spatial resolution (SR_b) is less than the values given in Formulae (6) and (7) depending on the object to detector distance b :

$$SR_b < \frac{\sqrt[3]{b}}{15} \quad (6)$$

for class A and

$$SR_b < \frac{\sqrt[3]{b}}{30} \quad (7)$$

for class B.

- b) If an unsharpness comparable to that obtained with film radiography (ISO 17636-1) is to be achieved, then f_{\min} should be increased compared with the values given by Formulae (1) or (2) (and Figure 21) using the following Formulae (8) and (9) if Formula (6) or (7) is fulfilled:

$$f_{\min} = d \sqrt{\frac{b^2}{(b^{2/3}/7,5^2) - 4SR_b^2}} \quad (8)$$

for class A and

$$f_{\min} = d \sqrt{\frac{b^2}{(b^{2/3}/15^2) - 4SR_b^2}} \quad (9)$$

for class B.

Formula (1) or (2) or Figure 21 can determine f_{\min} , if the detector basic spatial resolution SR_b is much less than required by Formula (6) or (7) or the IQI visibility as defined in Tables B.1 to B. 12 is achieved by increased SNR (CP II).

Tables B.13 and B.14 provide the maximum total image unsharpness values and SR_b requirements for sufficient image quality for class A and class B, respectively.

When using the elliptic technique specified in 7.1.6 or the perpendicular technique specified in 7.1.7, b shall be replaced by the external diameter D_e of the pipe in Formulae (1) and (2) and in Figure 21.

When the source is outside the object and the detector is on the other side (technique described in 7.1.8 as double wall penetration and single image) the minimum source-to-object distance is determined only by the wall thickness (i.e. not by the pipe diameter).

Where possible it is preferable to avoid usage of a double wall technique (see 7.1.6 to 7.1.8) by placing the radiation source inside the object to be radiographed, to achieve a more suitable direction of examination (see 7.1.4 and 7.1.5). The reduction in minimum source-to-object distance should not be greater than 20 %. When the source is located centrally inside the object and the detector outside (technique shown in 7.1.4) and provided that the IQI requirements are met, this percentage may be increased. However, the reduction in minimum source-to-object distance shall not be greater than 50 %. A further reduction can be agreed by the contracting parties provided that the IQI requirements are met.

7.7 Geometric magnification technique

An obstacle to the application of CR and DDA systems for weld radiography is the large ($\geq 50 \mu\text{m}$) pixel size of most digital detector arrays and most IP-scanner systems compared with the small grain size in film (which leads to film having very high spatial resolution). This difficulty can be circumvented by taking advantage of the unique property of DDAs to increase the SNR_N (CP II) in the image and/or the geometric magnification if needed.

NOTE Geometric magnification is different from digital magnification (zoom) of displayed images. Only geometric magnification provides a reduction in image unsharpness.

If the required IQI-sensitivity (proven by single wire or step hole IQI) and SR_b (proven by duplex wire IQI, see also Annex C) do not meet the requirements given in the appropriate Tables B.1 to B.14, one option is to increase the image signal to noise ratio (see 7.3.2, CP II).

Another option is the application of the geometric magnification technique with increased distance between the IP or DDA and the object combined with usage of an X-ray tube with a small focal spot or a gamma-ray source with small source size.

Finally, after employing both methods, if the required IQI values are still not visible, that CR system or the DDA cannot be used for that examination.

The correct selection of magnification shall be proven by usage of the duplex wire IQI on the object in all production radiographs. The duplex wire IQI shall be positioned on the side of the object nearer to the detector, if $2\text{SR}_b > d$ (source or focal spot size d). Otherwise, the duplex wire IQI shall be positioned on the source side of the object. It is recommended that duplex wire IQIs are positioned on both sides of the object for selection of the magnification value, but only one needs to be seen in the final production radiographs after selection of the correct magnification factor and source size or focal spot size.

IQIs may disturb digital images if automated defect recognition is applied. If no IQIs are used for a series of production radiographs, the image quality shall be proven periodically by reference images with wire IQIs or step hole IQIs and duplex IQIs.

The image unsharpness u_{Im} can be estimated from the magnification v , the geometric unsharpness u_G and the SR_b by Formula (10):

$$u_{\text{Im}} = \frac{1}{v} \sqrt{(u_G)^2 + (2\text{SR}_b)^2} \quad (10)$$

with

$$u_G = \left(\frac{\text{SDD}}{f} - 1 \right) d = (v - 1)d \quad (11)$$

where

SR_b is the basic spatial resolution of the detector with a magnification of 1;

SDD is the source-to-detector distance;

ISO 17636-2:2013(E)

- f is the source-to-object distance;
- u_G is the geometric unsharpness;
- d is the focal spot size or source size in accordance with EN 12543 or EN 12679;
- ν is the geometric magnification given by the ratio SDD/f ;
- u_{Im} is the required maximum image unsharpness in accordance with Table B.13 or Table B.14 for class A or B testing.

The magnification shall be increased and/or the focal spot size shall be decreased to reduce the image unsharpness so that it is less than or equal to the appropriate value specified in Tables B.13 or B.14. This shall be proven by a duplex wire IQI positioned on the object, as described in the preceding.

The magnification factor is typically different for the source and the detector sides of the object. Therefore, the magnification ν should be selected for the object centre. The variation of the magnification value between the source side and the detector side should be within $\pm 25\%$. Smaller magnification values may be chosen if the CP II as described in 7.3.2 is used.

7.8 Maximum area for a single exposure

The number of digital radiographs for a complete examination of flat welds (see Figures 1, 15, 17, and 18) and of curved welds with the radiation source arranged off-centre (see Figures 2 to 4 and 8 to 16) should be specified in accordance with technical requirements.

The ratio of the penetrated thickness at the outer edge of an evaluated area of uniform thickness to that at the centre beam shall not be more than 1,1 for class B and 1,2 for class A.

The SNR_N values resulting from any variation of penetrated thickness should not be lower than those indicated in Table 3 or 4. Alternatively, GVs may be used for CR as shown in Annex D.

The size of the area to be examined includes the weld and the heat-affected zones. In general, about 10 mm of parent metal shall be examined on each side of the weld.

Recommendations for the number of digital radiographs are indicated in Annex A which gives an acceptable examination of a circumferential butt weld.

7.9 Processing**7.9.1 Scan and read-out of image**

Detectors or scanners are to be used in accordance with the conditions recommended by the detector or scanner manufacturer to obtain the selected image quality. The digital radiographs should be free from artefacts due to processing and handling or other causes which would interfere with interpretation.

7.9.2 Calibration of DDAs

If using DDAs, the detector calibration procedure, as recommended by the manufacturer, shall be applied. The detector shall be calibrated with a background image (without radiation) and at least with one gain image (X-rays on and homogeneously exposed). Multi-gain calibration will increase the achievable SNR_N and linearity but takes more time. To minimize the noise due to calibration, all calibration images shall be taken with an exposure dose (milliampère minutes or gigabecquerel minutes) at least twice as large as the dose used for the inspection radiographs. Calibrated images should be treated as original images for quality assurance if the procedure has been documented. The calibration shall be performed periodically and if the exposure conditions change significantly.

7.9.3 Bad pixel interpolation

Bad pixels are underperforming detector elements of DDAs. They are described in ASTM E2597.^[11]

If using DDAs, the detector shall be mapped to determine the bad pixel map in accordance with the manufacturer guideline. This bad pixel map shall be documented. Bad pixel interpolation is acceptable and an essential procedure for radiography with DDAs. It is recommended that only DDAs having no cluster kernel pixels (CKP) in the region of interest (ROI) be used.

DDAs without CKPs and CR shall be applied for inspection, which have a basic spatial resolution (SR_b) of the detector less than or equal to that required in Table B.13 or B.14. If the magnification technique is used, then the SR_b^{image} shall be determined from the measured image as described in Annex C but with the duplex IQI directly on the test object (see 7.7). This SR_b value shall be less than or equal to the values given in Table B.13 or B.14. If the detector or image SR_b is higher than specified in Table B.13 or B.14, the CP II, as described in 7.2.3, may then be applied.

If using DDAs or imaging plates for inspection of flaw sizes of the order of the image SR_b^{image} the required SNR_N shall be increased significantly. The inspection shall be performed on the basis of an agreement between the contracting parties. The specified increase in SNR_N may compensate for locally increased unsharpness due to bad pixel interpolation.

The evaluation for bad pixels shall be performed periodically.

NOTE By analogy to the CP II the increased SNR_N also compensates also for the local unsharpness caused by bad pixel interpolation. This is considered as CP III.

7.9.4 Image processing

7.9.4.1 The digital data of the radiographic detector shall be evaluated with linearized grey value representation which is directly proportional to the radiation dose for determination of SNR, SR_b and SNR_N . For optimal image display, contrast and brightness should be interactively adjustable. Optional filter functions, profile plots and an SNR, SNR_N tool should be integrated into the software for image display and evaluation. For critical image analysis the operator shall interpret the image with a zoom factor between 1:1 (meaning 1 pixel of the digital radiograph is presented by one monitor pixel) and 1:2 (meaning 1 pixel of the digital radiograph is presented by four monitor pixels).

7.9.4.2 Further means of image processing applied on the stored raw data (e.g. high pass filtering for image display) shall be documented, be repeatable and be agreed between the contracting parties.

7.9.4.3 If further image processing (e.g. high pass filtering) is used when evaluating single wire or step hole IQI values, then the same filter parameters shall be used for both weld evaluation and IQI value determination.

7.10 Monitor viewing conditions and storage of digital radiographs

The digital radiographs shall be examined in a darkened room. The monitor setup shall be verified with a suitable test image.

The display for image evaluation shall fulfil minimum requirements a) to d):

- a) minimal brightness of 250 cd/m²;
- b) display of at least 256 shades of grey;
- c) minimum displayable light intensity ratio of 1:250;
- d) display of at least 1 million pixels of a pixel size <0,3 mm.

ISO 17636-2:2013(E)

The original images (region of interest) shall be stored at the full resolution as delivered by the detector system. Only image processing connected with the detector calibration (e.g. offset correction, gain calibration for detector equalization and bad pixel correction, see ASTM E2597^[11] for more details) to provide artefact-free detector images shall be applied before storage of these raw data.

The data storage shall be redundant and supported by suitable back-up strategies to ensure long-time storage using lossless data compression only.

8 Test report

For each exposure, or set of exposures, a test report shall be made giving information on the digital radiographic technique used, and on any other special circumstances which would allow a better understanding of the results.

The test report shall include at least the following information:

- a) name of the examination body;
- b) object;
- c) material;
- d) heat treatment;
- e) geometry of the weld;
- f) material thickness;
- g) welding process;
- h) specification of examination including requirements for acceptance;
- i) digital radiographic technique and class, required IQI sensitivity in accordance with this part of ISO 17636 (ISO 17636-2:2012);
- j) test arrangement in accordance with 7.1;
- k) magnification;
- l) system of marking used;
- m) detector position plan;
- n) radiation source, type and size of focal spot and identification of equipment used;
- o) detector, screens and filters and detector basic spatial resolution;
- p) achieved and required SNR_N for DDAs or achieved and required grey values and/or SNR_N for CR;
- q) for CR: scanner type and parameters such as pixel size, scan speed, gain, laser intensity, laser spot size;
- r) for DDAs: type and parameters such as gain, frame time, frame number, pixel size, calibration procedure;
- s) tube voltage used and current or source type and activity;
- t) time of exposure and source-to-detector distance;
- u) type and position of image quality indicators;

- v) results of examination including data on software used, IQI readings;
- w) image-processing parameters used, e.g. of the digital filters;
- x) any deviation from this part of ISO 17636, by special agreement;
- y) name, certification and signature of the responsible person(s);
- z) date(s) of exposure and test report.

Annex A (normative)

Recommended number of exposures which give an acceptable examination of a circumferential butt weld

The minimum number of exposures required is presented in Figures A.1 to A.4, which are valid for pipes with an external diameter exceeding 100 mm.

When the deviation of the wall thickness of the joint to be examined, when using a single exposure $\Delta t/t$ does not exceed 20 %, Figures A.3 and A.4 are used. This technique is recommended only when the possibility of having transverse cracks is small or the weld is examined for such imperfections by other non-destructive examination methods.

When $\Delta t/t$ is less than or equal to 10 %, Figures A.1 and A.2 are used. In this case, it is likely that transverse cracks are also detected.

If the object is examined for single transverse cracks, then the required minimum number of digital radiographs increases compared with the values in Figures A.1 to A.4.

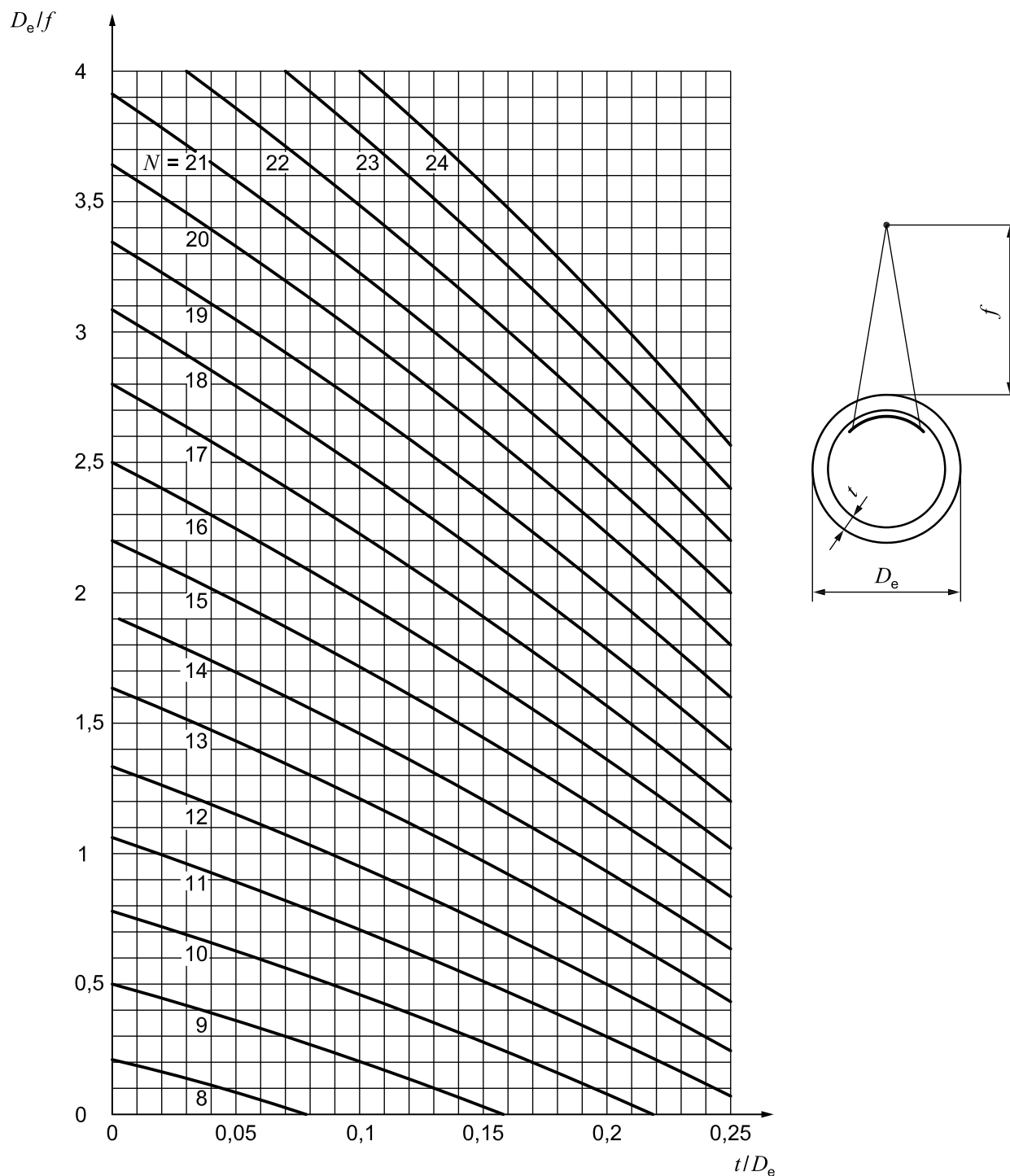
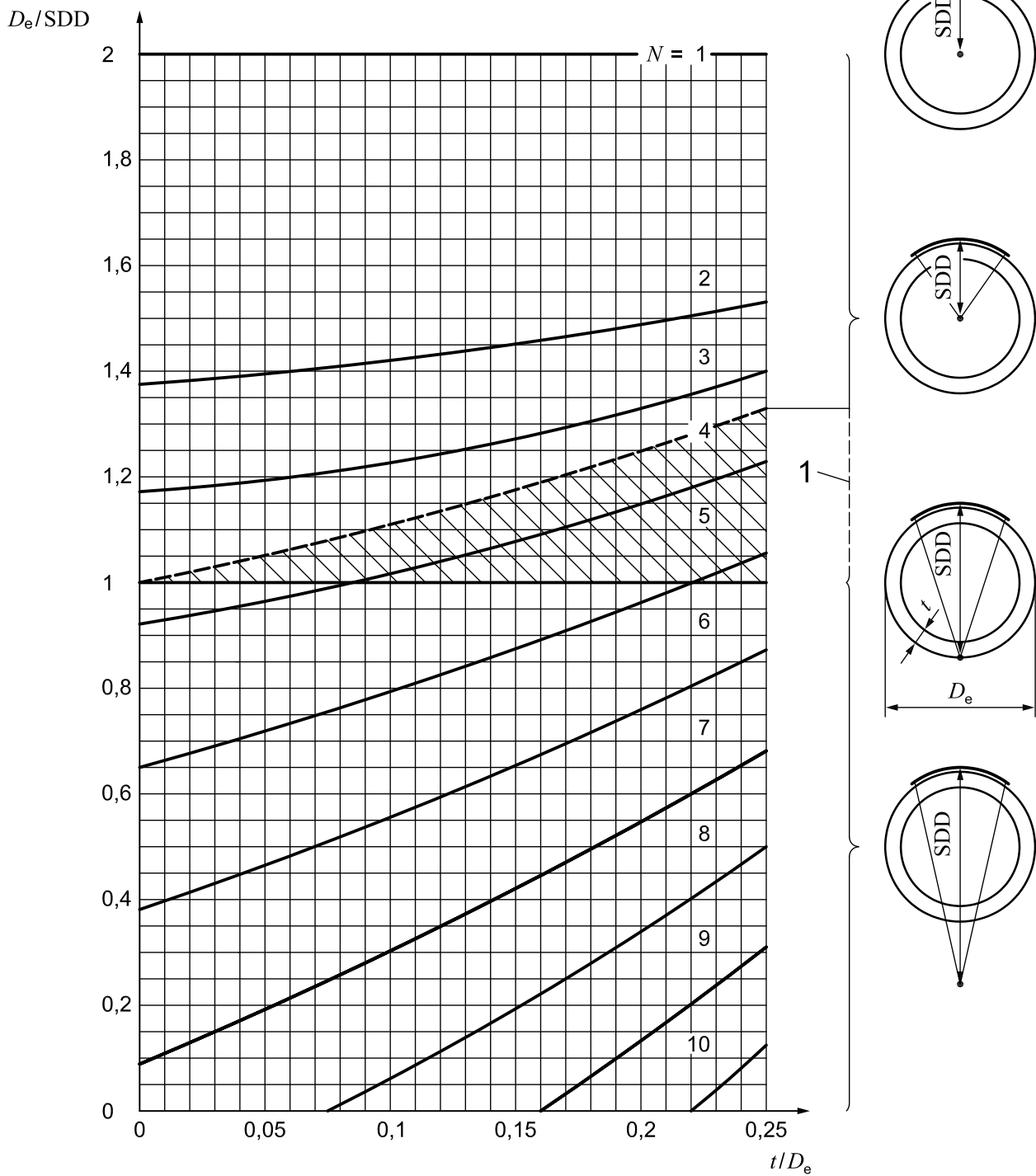

Figure A.1 — Minimum number of exposures N for single wall penetration with source outside, with a maximum permissible increase in penetrated thickness $\Delta t/t$ due to inclined penetration in the areas to be evaluated of 10 % (class B), as a function of ratios t/D_e and D_e/f

ISO 17636-2:2013(E)



Key

1 pipe wall

Figure A.2 — Minimum number of exposures N for off-centre penetration with source inside and for double wall penetration, with a maximum permissible increase in penetrated thickness $\Delta t/t$ due to inclined penetration in the areas to be evaluated of 10 % (class B), as a function of ratios t/D_e and D_e/SDD

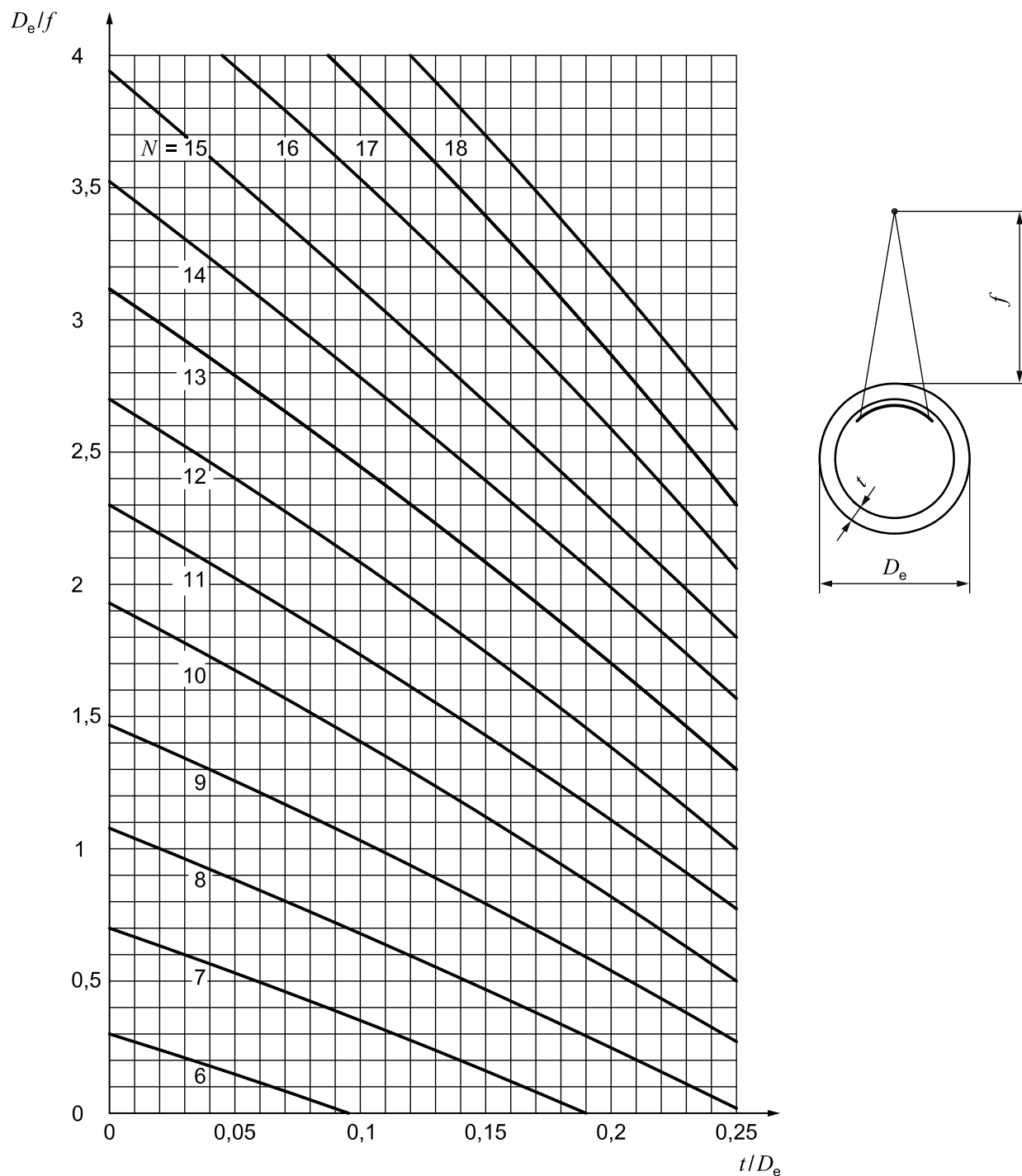

Figure A.3 — Minimum number of exposures N for single wall penetration with source outside, with a maximum permissible increase in penetrated thickness $\Delta t/t$ due to inclined penetration in the areas to be evaluated of 20 % (class A), as a function of ratios t/D_e and D_e/f

ISO 17636-2:2013(E)

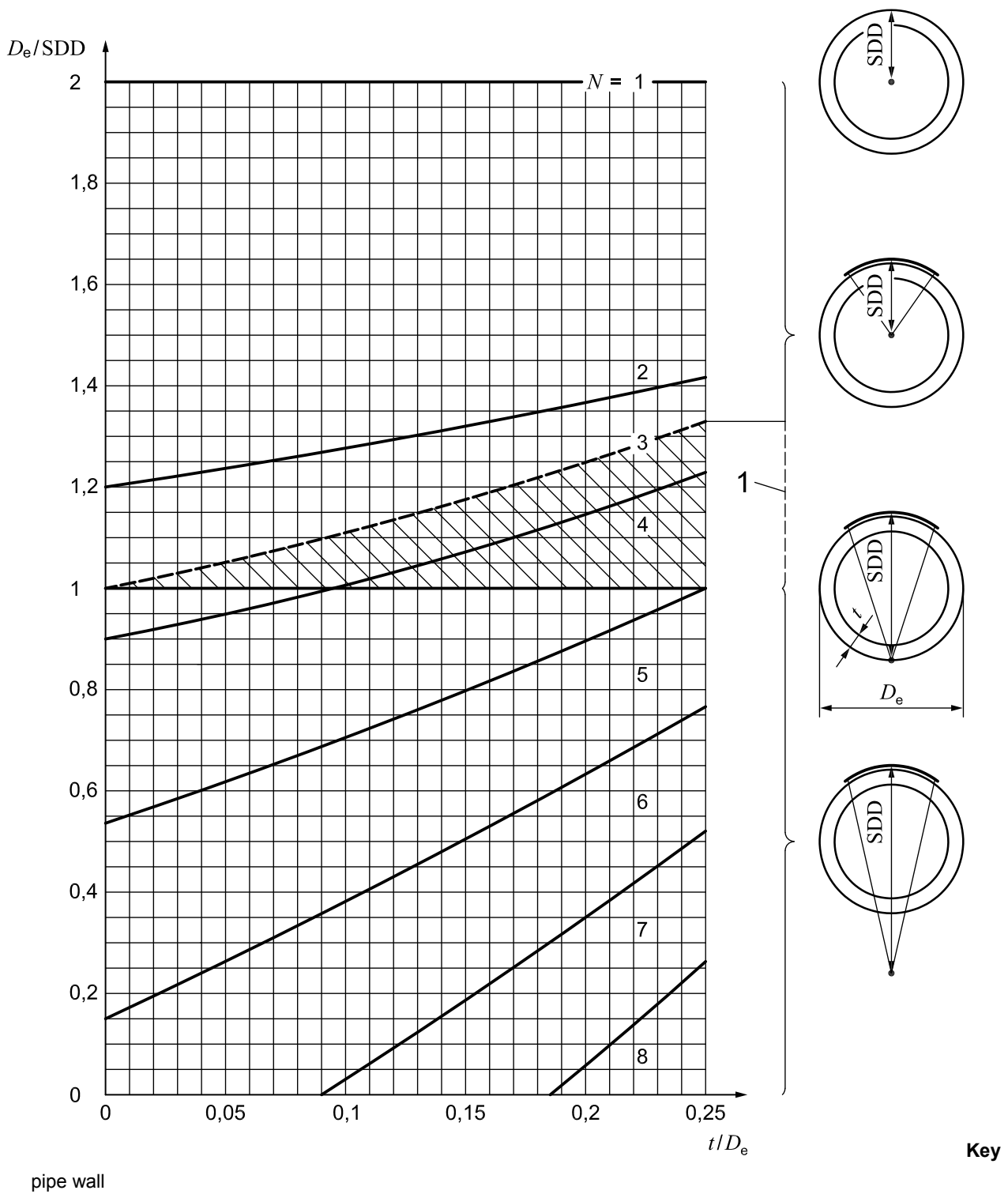

Figure A.4 — Minimum number of exposures N for off-centre penetration with source inside and for double wall penetration, with a maximum permissible increase in penetrated thickness $\Delta t/t$ due to inclined penetration in the areas to be evaluated of 20 % (class A), as a function of ratios t/D_e and D_e/SDD

Annex B
(normative)

Minimum image quality values

ISO 17636-2:2013(E)

B.1 Single wall technique; IQI on source side

Table B.1 — Wire IQI

Image quality class A			
Nominal thickness t mm			IQI value
		to 1,2	W 18
above	1,2	to 2,0	W 17
above	2,0	to 3,5	W 16
above	3,5	to 5,0	W 15
above	5,0	to 7	W 14
above	7	to 10	W 13
above	10	to 15	W 12
above	15	to 25	W 11
above	25	to 32	W 10
above	32	to 40	W 9
above	40	to 55	W 8
above	55	to 85	W 7
above	85	to 150	W 6
above	150	to 250	W 5
above	250		W 4

Table B.2 — Step and hole IQI

Image quality class A			
Nominal thickness t mm			IQI value
		to 2,0	H 3
above	2,0	to 3,5	H 4
above	3,5	to 6	H 5
above	6	to 10	H 6
above	10	to 15	H 7
above	15	to 24	H 8
above	24	to 30	H 9
above	30	to 40	H 10
above	40	to 60	H 11
above	60	to 100	H 12
above	100	to 150	H 13
above	150	to 200	H 14
above	200	to 250	H 15
above	250	to 320	H 16
above	320	to 400	H 17
above	400		H 18

Table B.3 — Wire IQI

Image quality class B			
Nominal thickness t mm			IQI value
		to 1,5	W 19
above	1,5	to 2,5	W 18
above	2,5	to 4	W 17
above	4	to 6	W 16
above	6	to 8	W 15
above	8	to 12	W 14
above	12	to 20	W 13
above	20	to 30	W 12
above	30	to 35	W 11
above	35	to 45	W 10
above	45	to 65	W 9
above	65	to 120	W 8
above	120	to 200	W 7
above	200	to 350	W 6
above	350		W 5

Table B.4 — Step and hole IQI

Image quality class B			
Nominal thickness t mm			IQI value
		to 2,5	H 2
above	2,5	to 4	H 3
above	4	to 8	H 4
above	8	to 12	H 5
above	12	to 20	H 6
above	20	to 30	H 7
above	30	to 40	H 8
above	40	to 60	H 9
above	60	to 80	H 10
above	80	to 100	H 11
above	100	to 150	H 12
above	150	to 200	H 13
above	200	to 250	H 14

B.2 Double wall technique; double image; IQI on source side**Table B.5 — wire IQI**

Image quality class A				IQI value
Penetrated thickness w mm				
		to	1,2	W 18
above	1,2	to	2	W 17
above	2	to	3,5	W 16
above	3,5	to	5	W 15
above	5	to	7	W 14
above	7	to	12	W 13
above	12	to	18	W 12
above	18	to	30	W 11
above	30	to	40	W 10
above	40	to	50	W 9
above	50	to	60	W 8
above	60	to	85	W 7
above	85	to	120	W 6
above	120	to	220	W 5
above	220	to	380	W 4
above	380			W 3

Table B.6 — Step and hole IQI

Image quality class A				IQI value
Penetrated thickness w mm				
		to	1	H 3
above	1	to	2	H 4
above	2	to	3,5	H 5
above	3,5	to	5,5	H 6
above	5,5	to	10	H 7
above	10	to	19	H 8
above	19	to	35	H 9

Table B.7 — Wire IQI

Image quality class B				IQI value
Penetrated thickness w mm				
		to	1,5	W 19
above	1,5	to	2,5	W 18
above	2,5	to	4	W 17
above	4	to	6	W 16
above	6	to	8	W 15
above	8	to	15	W 14
above	15	to	25	W 13
above	25	to	38	W 12
above	38	to	45	W 11
above	45	to	55	W 10
above	55	to	70	W 9
above	70	to	100	W 8
above	100	to	170	W 7
above	170	to	250	W 6
above	250			W 5

Table B.8 — Step and hole IQI

Image quality class B				IQI value
Penetrated thickness w mm				
		to	1	H 2
above	1	to	2,5	H 3
above	2,5	to	4	H 4
above	4	to	6	H 5
above	6	to	11	H 6
above	11	to	20	H 7
above	20	to	35	H 8

ISO 17636-2:2013(E)

B.3 Double wall technique: single or double image; IQI on detector side

Table B.9 — Wire IQI

Image quality class A				IQI value
Penetrated thickness w mm				
		to	1,2	W 18
above	1,2	to	2	W 17
above	2	to	3,5	W 16
above	3,5	to	5	W 15
above	5	to	10	W 14
above	10	to	15	W 13
above	15	to	22	W 12
above	22	to	38	W 11
above	38	to	48	W 10
above	48	to	60	W 9
above	60	to	85	W 8
above	85	to	125	W 7
above	125	to	225	W 6
above	225	to	375	W 5
above	375			W 4

Table B.10 — Step and hole IQI

Image quality class A				IQI value
Penetrated thickness w mm				
		to	2	H 3
above	2	to	5	H 4
above	5	to	9	H 5
above	9	to	14	H 6
above	14	to	22	H 7
above	22	to	36	H 8
above	36	to	50	H 9
above	50	to	80	H 10

Table B.11 — Wire IQI

Image quality class B				IQI value
Penetrated thickness w mm				
		to	1,5	W 19
above	1,5	to	2,5	W 18
above	2,5	to	4	W 17
above	4	to	6	W 16
above	6	to	12	W 15
above	12	to	18	W 14
above	18	to	30	W 13
above	30	to	45	W 12
above	45	to	55	W 11
above	55	to	70	W 10
above	70	to	100	W 9
above	100	to	180	W 8
above	180	to	300	W 7
above	300			W 6

Table B.12 — Step and hole IQI

Image quality class B				IQI value
Penetrated thickness w mm				
		to	2,5	H 2
above	2,5	to	5,5	H 3
above	5,5	to	9,5	H 4
above	9,5	to	15	H 5
above	15	to	24	H 6
above	24	to	40	H 7
above	40	to	60	H 8
above	60	to	80	H 9

B.4 Unsharpness

Table B.13 — Maximum image unsharpness for all techniques Class A

Image Quality Class A: Duplex wire ISO 19232-5		
Penetrated thickness w^a mm	Minimum IQI value and maximum unsharpness (ISO 19232-5) ^b mm	Maximum basic spatial resolution (equivalent to wire thickness and spacing) ^b SR_b^{image} mm
$w \leq 1,0$	D 13 0,10	0,05
$1,0 < w \leq 1,5$	D 12 0,125	0,063
$1,5 < w \leq 2$	D 11 0,16	0,08
$2 < w \leq 5$	D 10 0,20	0,10
$5 < w \leq 10$	D 9 0,26	0,13
$10 < w \leq 25$	D 8 0,32	0,16
$25 < w \leq 55$	D 7 0,40	0,20
$55 < w \leq 150$	D 6 0,50	0,25
$150 < w \leq 250$	D 5 0,64	0,32
$w > 250$	D 4 0,80	0,4

^a For double wall technique, single image, the nominal thickness t shall be used instead of the penetrated thickness w .

^b The IQI reading for system selection (see Annex C) applies for contact radiography. If geometric magnification technique (see 7.7) is used, the IQI reading shall be performed in the corresponding reference radiographs.

ISO 17636-2:2013(E)

Table B.14 — Maximum image unsharpness for all techniques Class B

Image Quality Class B: Duplex wire ISO 19232-5		
Penetrated thickness w^a mm	Minimum IQI value and maximum unsharpness (ISO 19232-5) ^b mm	Maximum basic spatial resolution (equivalent to wire thickness and spacing) ^b SR_b^{image} mm
$w \leq 1,5$	D 13+ 0,08	0,04
$1,5 < w \leq 4$	D 13 0,10	0,05
$4 < w \leq 8$	D 12 0,125	0,063
$8 < w \leq 12$	D 11 0,16	0,08
$12 < w \leq 40$	D 10 0,20	0,10
$40 < w \leq 120$	D 9 0,26	0,13
$120 < w \leq 200$	D 8 0,32	0,16
$w > 200$	D 7 0,40	0,20

^a For double wall technique, single image, the nominal thickness t shall be used instead of the penetrated thickness w .

^b The IQI reading for system selection (see Annex C) applies for contact radiography. If geometric magnification technique (see 7.7) is used, the IQI reading shall be performed in the corresponding reference radiographs.

NOTE "D 13+" is achieved if the duplex wire pair D 13 is resolved with a dip larger than 20 %.

Annex C (normative)

Determination of basic spatial resolution

Linearized grey levels are the precondition for the measurement of correct basic spatial resolution values. This means the grey values need to be proportional to the radiation exposure at a given location of the image. This is typically supported by the manufacturer's software.

The duplex wire IQI shall be positioned directly on the detector surface or cassette surface and shall be read in accordance with ISO 19232-5 for determination of the detector basic spatial resolution SR_b .

NOTE If the duplex wire IQI is positioned on a test object, instead of directly on the detector, a measurement of the image basic spatial resolution SR_b^{image} is then obtained, not the detector basic spatial resolution $SR_b^{detector}$.

If the first unsharp wire pair cannot be recognized clearly (see ISO 19232-5), the 20 % dip method shall be applied as follows.

On the digital radiograph, the first wire pair giving a modulation (dip) of less than 20 % in relation to the double peak size (see Figure C.1) shall be documented as result of the IQI test [e.g. D8 as shown in Figure C.1 c)]. A profile function of the image-processing software shall be used to recognize the first wire pair with a dip of less than 20 % [when averaged over both minima — see Figure C.1 d)]. The profile shall also be averaged [see Figure C.1 b) and c)] over at least 21 single line profiles to improve the SNR in the profile plot.

By usage of the duplex wire IQI, conforming to ISO 19232-5, the inherent image unsharpness u_i shall be determined and the basic spatial resolution SR_b of the detector shall be calculated with:

$$SR_b = \frac{1}{2} u_i \quad (C.1)$$

The duplex wire IQI shall be positioned at an angle of approximately 2° to 5° towards the pixel line or column orientation in order to avoid aliasing effects as shown in Figure C.1.

The determination of the basic spatial resolution for a digital detector system (SR_b) shall be performed under one of the following exposure conditions without object:

- a) inspection of light alloys:
 - tube voltage 90 kV,
 - prefilter 1 mm Al;
- b) inspection of steel and copper alloys ≤ 20 mm penetrated thickness:
 - tube voltage 160 kV,
 - prefilter 1 mm Cu;
- c) inspection of steel and copper alloys > 20 mm penetrated thickness:
 - tube voltage 220 kV,
 - prefilter 2 mm Cu;

ISO 17636-2:2013(E)

d) gamma-radiography or high energy radiography:

- use the gamma-ray source as specified or X-ray source >1 MV,
- prefilter 2 mm Cu or 4 mm steel for Se 75, Ir 192, and 4 mm Cu or 8 mm steel for Co 60 or X-ray voltage >1 MV.

The duplex wire shall be positioned directly on the detector surface or cassette surface. The source to detector distance shall be (100 ± 5) cm. The mean grey value in the digital image shall exceed 50 % of the maximum grey value the SNR shall exceed 100 for standard systems with pixel size $\geq 80 \mu\text{m}$ or 70 for high-resolution systems with pixel size $< 80 \mu\text{m}$ in the reference radiograph. The basic spatial resolution (see Formula C.1) as measured in the reference radiograph for the digital system used and the system settings shall be recorded in the test report.

The detector basic spatial resolution of CR systems shall be measured both perpendicular and parallel to the scanning direction of the laser. The higher value of the two SR_b values shall be used as the resulting detector basic spatial resolution (SR_b or SR_b^{detector}).

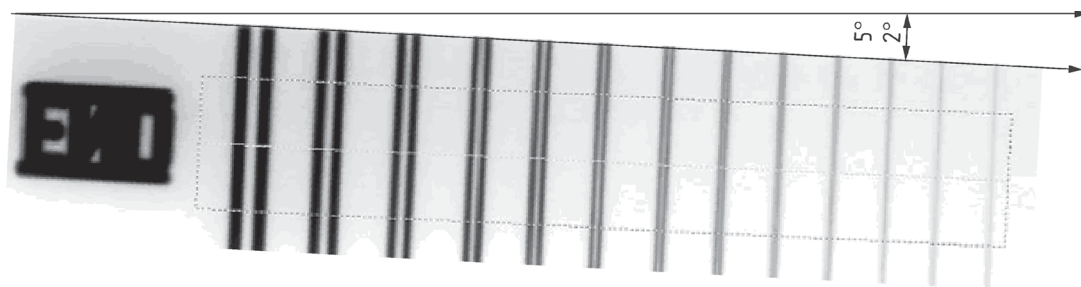

a) Image of the duplex wire IQI as shown in a radiograph

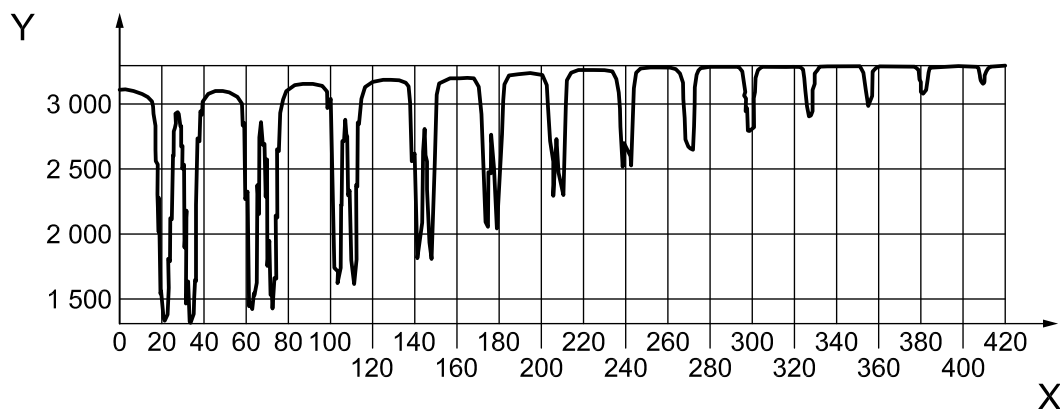

b) Profile of the duplex wire IQI averaged from at least 21 lines

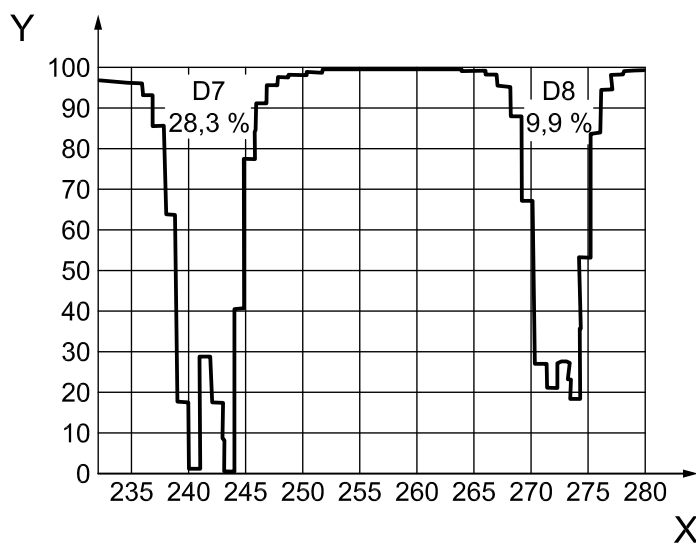

c) Zoomed profile of wire pair D7 and D8

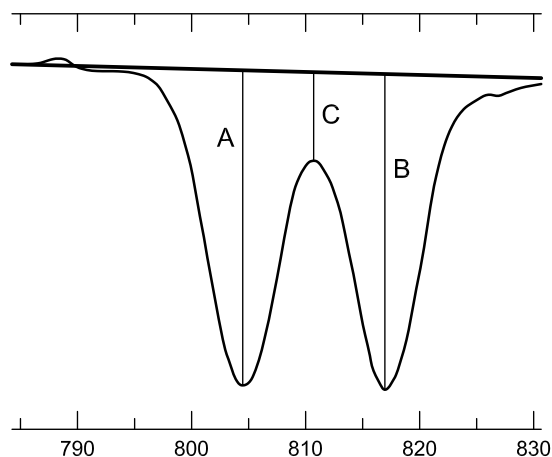
d) Scheme for calculation of the dip value (in %) with: $\text{dip} = 100 \times (A + B - 2C)/(A+B)$ **Key**

D7, D8	duplex wire IQI values
X	distance
Y	amplitude

Figure C.1 — Example for duplex wire IQI evaluation with resulting IQI value D8, being the first one with a dip <20%

ISO 17636-2:2013(E)

For improved accuracy in the measurement of the SR_b or SR_b^{detector} value the 20 % dip value should be interpolated from the modulation depth (dip) of the neighbour duplex wire modulations. Figure C.2 represents the corresponding procedure for a high-resolution CR system.

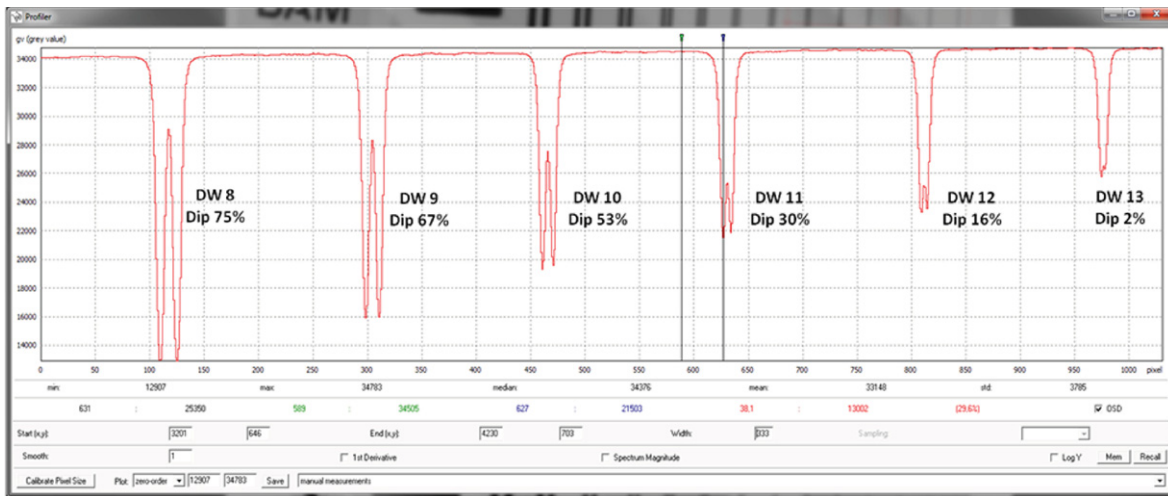

a) Profile plot of measured profile of a high-resolution system with determined modulation depths (dips)

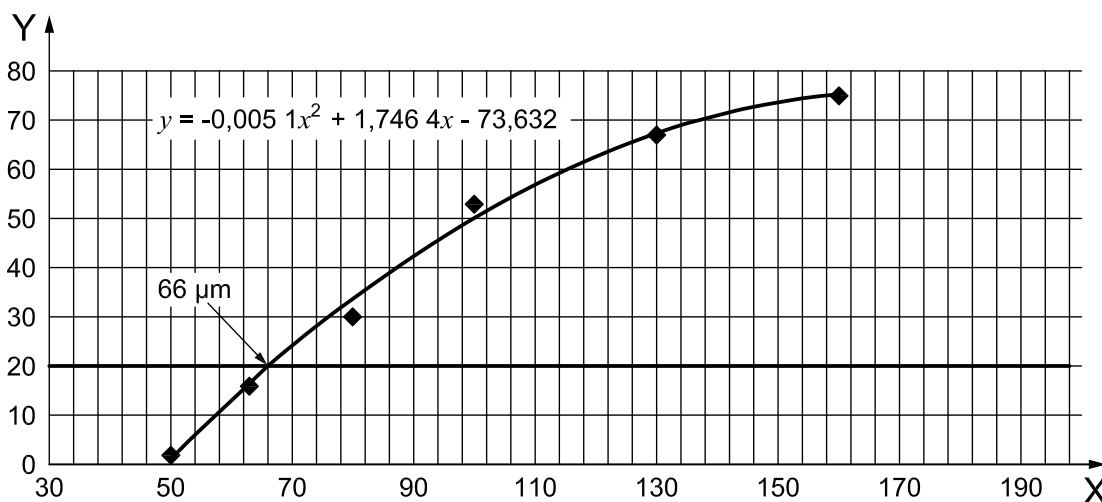

b) Interpolation of modulation depth vs. duplex wire diameter (corresponds to SR_b). The 20 % value is determined from the intersection with the 20 % line resulting in iSR_b of 66 μm

Figure C.2 — Example of the determination of the interpolated basic spatial resolution (iSR_b^{detector}) by interpolation from the measured modulation (dip) of the neighbour duplex wire elements

The dependence of modulation (dip) from wire diameter should be fitted with a polynomial of second order for calculation of the intersection with the 20 % line as indicated in Figure C.2. Modulation values greater than zero shall be used for the interpolation only.

The interpolated SR_b -value (see Figure C.2) shall be recorded as “interpolated SR_b -value” or iSR_b^{detector} . This value may be used instead of the non-interpolated SR_b value by agreement of the contracting parties.

Annex D (normative)

Determination of minimum grey values for CR practice

D.1 Determination of SNR_N from $SNR_{measured}$

The procedure for measurement of the signal-to-noise ratio is specified in ISO 16371-1:2011, 6.1, in detail. The measured signal to noise ratio, $SNR_{measured}$, is typically determined in a window of 20×55 pixels (called the region of interest) as the ratio of the linearized mean grey value to its standard deviation as specified in ISO 16371-1:2011, 6.1.1. The linearized grey value is directly proportional to the dose of radiation at the measured region of interest (ROI) and it is zero for unexposed areas. This mode shall be selected for SNR_N measurements.

NOTE The window for the SNR measurement should be limited in width to 20 pixels. The length can be ≥ 55 pixel. Larger length increases the accuracy of the SNR measurement. This applies especially if the median of the line SNR values is considered in the software tool as specified in ISO 16371-1.

For similar radiation exposures, unsharp digital systems achieve a higher measured SNR than sharp ones, but have lower performance for detection of fine flaws than sharp systems. Therefore, the measured SNR is normalized by the basic spatial resolution. Systems with same normalized basic spatial resolution have similar visualization performance for fine details.

The normalization is based on the basic spatial resolution value of the CR system (SR_b) as provided by the manufacturer or determined by the user by the procedure specified in Annex C.

All SNR_N values are normalized as follows:

$$SNR_N = SNR_{measured} \times \frac{88,6 \mu m}{SR_b} \quad (D.1)$$

The SNR_N value is typically provided by the manufacturer's software, if the basic spatial resolution has been entered in the software tool and a ROI is marked for measurement.

A new qualification of the CR system by measurement of the basic spatial resolution, SR_b , is required if any scanner parameters, such as pixel resolution, scan speed and/or the imaging plate type, have been changed.

Table D.1 provides SNR_N values and the conversion to unnormalized SNR values for CR systems with different SR_b performance. If the manufacturer's software does not provide SNR_N values, the user can determine the converted SNR values for usage instead of the SNR_N values from Table D.1.

ISO 17636-2:2013(E)

Table D.1 — Required $SNR_{measured}$ values for selected CR systems with different SR_b as equivalent to SNR_N

System parameter	High definition system				Standard system				
Duplex wire qualification	13+	13	12	11	10	9	8	7	6
Basic spatial resolution SR_b	40 μm	50 μm	63 μm	80 μm	100 μm	130 μm	160 μm	200 μm	250 μm
Required SNR_N (Tables 3 and 4)	Required $SNR_{measured}$								
150	65	85	110	135	170	220	270	340	425
120	55	70	85	110	135	180	220	270	340
100	45	60	75	90	115	150	185	225	285
70	35	40	50	65	80	105	130	160	200

D.2 Determination of minimum grey values

When performing a CR inspection of objects of inhomogeneous thickness, it may be preferable to specify minimum grey levels instead of minimum SNR_N values, because SNR_N measurements need a zone of homogeneous grey level distribution in the digital image. It also may simplify the usage of different image-processing software.

Linearized grey levels are the precondition for the measurement of correct SNR_N values and equivalent grey values. This means the grey values need to be directly proportional (no offset) to the radiation exposure at a given location of the scanned imaging plate. This is typically supported by the manufacturer's software.

The dependence of image SNR_N on the grey mean value can be exploited using the CR technology, if no image processing has been performed and the CR system provides linearized grey levels. The relationship between grey levels and SNR_N can be used for a given set of scanner type and scanner parameters and the same type and brand of imaging plates only. Changing any scanner settings such as pixel size, scan speed, photomultiplier voltage or gain requires a new determination of the minimum grey value equivalent to the required SNR_N .

NOTE For CR, the correlation between SNR_N and mean grey value is widely independent of the kilovolt and milliampère settings above 50 kV to a few megavolt X-ray tube voltage and also for gamma-ray sources. This does not apply to DDAs. A qualification of minimum grey values, being equivalent to minimum SNR_N values can be used with any of the exposure conditions as specified in Annex C.

To determine a minimum grey value as being equivalent to a minimum SNR_N value of Table 3 or 4, the procedure can be applied as specified in a) to d).

- Perform an exposure of a step wedge as specified in Figure D.1. The use of a step wedge with large area steps is recommended to avoid shading effects. The step wedge should cover the complete digital image of the detector.
- Measure in each step the mean grey value and the SNR_N as shown in Figure D.2.
- Plot in a graph the measured SNR_N (or SNR) as a function of the mean grey value (see Figure D.3).
- Determine the equivalent minimum grey value for the minimum SNR_N which is required for the specification in accordance with Table 3 or Table 4. Table D.2 shows an example.

The resulting grey value can be taken for determination of the minimum CR grey value GV_{min} equivalent to the minimum optical film density in film radiography (see Figure D.3).

Alternatively to the procedure above, the IP can be exposed sequentially with different exposures (milliampère minutes) (X-ray sources) or exposure times (gamma-ray sources). The exposures should be taken under the same conditions as described in Annex C.

Additional screens or plates of steel or aluminium shall be used in front of the IP cassette or IP envelope, if this is applied for the production radiographs. The minimum grey values GV_{\min} shall be determined from the digital radiographs in equivalence to the achieved and required SNR_N or SNR (see Figure D.3) as specified in Table D.1.

No SNR or SNR_N values need to be measured in the production radiographs, if the specified minimum grey value GV_{\min} is achieved everywhere in the region of interest in a production radiograph.

It is recommended that a diagram is plotted as shown in Figure D.3 for better accuracy.

If minimum grey values GV_{\min} are used for the specification, the exact settings of the CR scanner and the corresponding IP type shall be documented.

The final specification of the minimum grey values should be given in a table as in for example Table D.2.

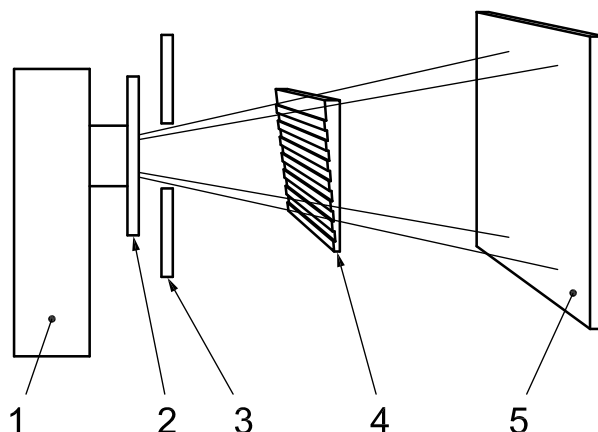

Key

- 1 X-ray tube
- 2 Cu-filter
- 3 Collimator
- 4 Cu-step wedge
- 5 IP in cassette

Figure D.1 — Set up for determination of CR equivalent grey values for required minimum SNR_N of Tables 3 or 4

ISO 17636-2:2013(E)

Figure D.2 — Measurement results of mean grey value and SNR_N of a step of the step wedge image

Table D.2 — Example for a specification of minimum grey values (see also Figure D.3)

Required SNR_N	Corresponding minimum grey levels for gain set 1	Corresponding minimum grey levels for gain set 2
150	1 250	2 500
120	1 015	2 030
100	590	1 180
70	270	540

**Key**

- 1 step wedge measurement value
- 2 fitted curve for step wedge measurement
- X grey value GV
- Y normalized SNR_N

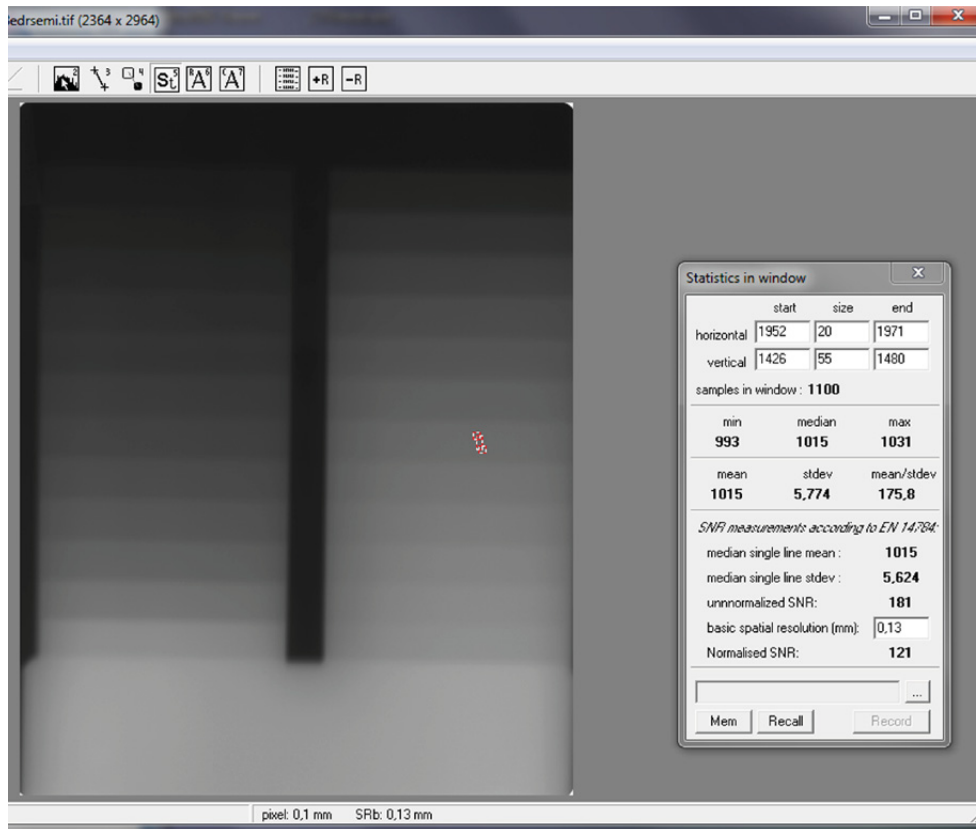
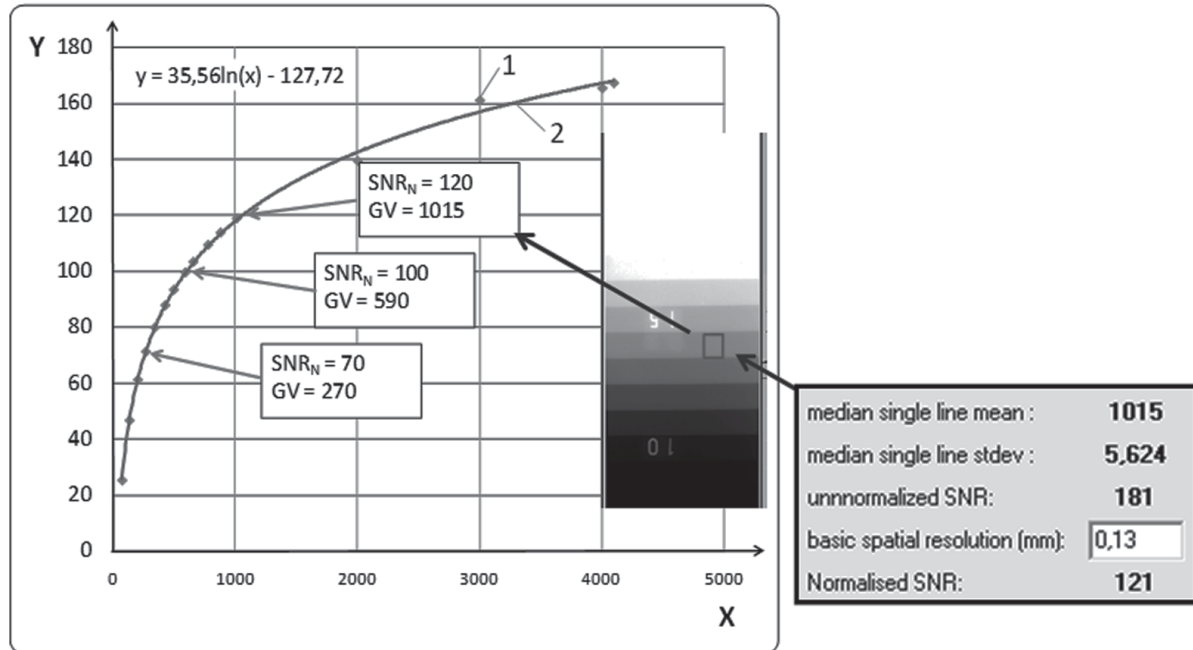
Figure D.3 — Graphical plot of SNR_N vs. mean grey values as measured in accordance with Figure D.2

NOTE The grey values can be specified as equivalent value for different SNR_N values of the CR scanner used, its scan parameters (e.g. gain set 1) and IP type.

Some scanner systems may provide degraded SNR_N values at very high grey values and low gain settings. If this is observed, maximum grey levels shall also be specified which shall not be exceeded.

Annex E (informative)

Grey values, general remarks

E.1 Introduction

In computed radiography, grey values may be used to render visual perceptions (visibility) as function of image contrast and noise (SNR or grey value is used in lieu of optical density and film system class in film radiography); thus, linear original grey values are used to measure the quantity of radiation penetrating a particular area of a part. With this relationship, a grey value of “0” corresponds to “0” radiation dose (white in a negative presentation as in film radiography) whereas a grey value of “4095” corresponds to a saturated detector (black in a negative presentation as in film radiography) for a 12 bit CR system.

grey value and SNR_N measurements shall be performed using qualified software tools that determine average grey value (mean value) within an ROI and/or SNR_N which is the ratio of the average grey value to the standard deviation of the grey values within the ROI. The minimum image area of the ROI shall contain 1 100 pixels (i.e. 20×55 pixels, see ISO 16371-1) for quantitative measurements.

NOTE Measured grey values of imaging plates are exactly proportional to the exposure dose for a given radiation quality. The internal (electronic) gain setting of the scanner and the photomultiplier properties as well as the analogue-to-digital converter properties (e.g. number of bits) determine the proportionality factor between dose and grey value. Any changes of these parameters require a new qualification of the minimum grey values as determined in Annex D. Some systems provide grey values in a logarithmic or square root characteristic or normalized values with unknown zero value. These values shall be linearized and related to the real zero value (corresponding to zero exposure dose), otherwise the grey values shall not be treated as equivalent to the optical density of films and cannot be used for SNR or CNR measurements. grey values and SNR_N values shall be determined before any digital filtering of the digital radiograph.

E.2 Noise control

Computed radiographic images become “noisy”, when exposed under suboptimal conditions. Excessive CR image noise (low SNR_N or CNR) can become a significant obstacle to the achievement of image quality requirements.

Suboptimal conditions to avoid include a) to f).

- a) Low exposure doses from X-ray or gamma-ray sources yield low CNRs. The CNR increases nonlinearly with increasing exposure (milliampère seconds or gigabecquerel minutes) up to the maximum achievable value due to the structure noise (fixed pattern noise) of real detectors.
- b) IPs generate image noise due to the internal structure of the radiation sensitive crystals and surface roughness. For high-quality level radiography, IPs should be selected with low structure noise (fine-grained type). The manufacturer should provide information on the maximum achievable SNR_N of the IP-scanner systems.
- c) DDAs generate structure noise due to different properties of the detector elements. These can be equalized by a calibration procedure. Modern calibration strategies allow very high SNRs to be achieved. Thermal and other effects as well as the limited exposure time of calibration images limit the effectiveness of the calibration and a small residual fixed pattern noise remains.
- d) Noise is generated by some materials, such as highly nickel-based alloys or rough surfaces. The noise may hide the visibility of fine flaws and even reduce the IQI reading.

- e) Backscatter contributes to the grey value level in the images and to the noise significantly. Since it does not typically contribute to the radiographic image contrast (CNR) the visibility of IQIs is reduced.
- f) Excessively high radiation energy yields low contrast at constant noise level (for the same grey value level). This reduces the CNR and therefore the IQI visibility. This may be compensated by increasing the required grey level or reduction of X-ray voltage in comparison to film radiography (CP I).

Bibliography

- [1] ISO 5579, *Non-destructive testing — Radiographic testing of metallic materials using film and X- or gamma-rays — Basic rules*
- [2] ISO 5580, *Non-destructive testing — Industrial radiographic illuminators — Minimum requirements*
- [3] ISO 19232-3, *Non-destructive testing — Image quality of radiographs — Part 3: Image quality classes for ferrous metals*
- [4] EN 444, *Non-destructive testing — General principles for radiographic examination of metallic materials by X- and gamma-rays*
- [5] EN 12681, *Founding — Radiographic examination*
- [6] EN 14784-2, *Non-destructive testing — Industrial computed radiography with storage phosphor imaging plates — Part 2: General principles for testing of metallic materials using X-rays and gamma rays*
- [7] EN 25580, *Non-destructive testing — Industrial radiographic illuminators — Minimum requirements (ISO 5580:1985)*
- [8] ASTM E1000, *Standard Guide for Radioscopy*
- [9] ASTM E2445, *Standard Practice for Qualification and Long-Term Stability of Computed Radiology Systems*
- [10] ASTM E2446, *Standard Practice for Classification of Computed Radiology Systems*
- [11] ASTM E2597, *Standard Practice for Manufacturing Characterization of Digital Detector Arrays*
- [12] ASTM E2698, *Standard Practice for Radiological Examination Using Digital Detector Arrays*
- [13] ASTM E2736, *Standard Guide for Digital Detector Array Radiology*
- [14] ASTM E 2737, *Standard Practice for Digital Detector Array Performance Evaluation and Long-Term Stability*

ISO 17636-2:2013(E)

ICS 25.160.40

Price based on 52 pages