



---

**P O L S K A N O R M A**

---

ICS 77.140.85; 77.040.20

**PN-EN 10228-4**

**Wprowadza**  
EN 10228-4:2016, IDT

**Zastępuje**  
PN-EN 10228-4:2000

## **Badania nieniszczące odkuwek stalowych**

### **Część 4: Badanie ultradźwiękowe odkuwek ze stali nierdzewnych austenitycznych i austenityczno-ferrytycznych**

**Norma Europejska EN 10228-4:2016 *Non-destructive testing of steel forgings – Part 4: Ultrasonic testing of austenitic and austenitic-ferritic stainless steel forgings* ma status Polskiej Normy**

© Copyright by PKN, Warszawa 2016

nr ref. PN-EN 10228-4:2016-07

---

**Wszelkie prawa autorskie zastrzeżone. Żadna część niniejszej publikacji nie może być zwielokrotniana jakkolwiek techniką bez pisemnej zgody Prezesa Polskiego Komitetu Normalizacyjnego**

---

ISBN 978-83-275-6414-6

## **PN-EN 10228-4:2016-07**

### **Przedmowa krajowa**

Niniejsza norma została zatwierdzona przez Prezesa PKN dnia 21 lipca 2016 r.

Komitetem krajowym odpowiedzialnym za normę jest KT nr 123 ds. Badań Własności Metali.

Istnieje możliwość przetłumaczenia normy na język polski na wniosek zainteresowanych środowisk. Decyzję podejmuje właściwy Komitet Techniczny.

Niniejsza norma zastępuje PN-EN 10228-4:2000.

Odpowiedniki krajowe norm i innych dokumentów powołanych w niniejszej normie można znaleźć w katalogu Polskich Norm. Oryginały norm i innych dokumentów powołanych są dostępne w PKN.

W sprawach merytorycznych dotyczących treści normy można zwracać się do właściwego Komitetu Technicznego lub właściwej Rady Sektorowej PKN, kontakt: [www.pkn.pl](http://www.pkn.pl).

### **Nota uznaniowa**

Norma Europejska EN 10228-4:2016 została uznana przez PKN za Polską Normę PN-EN 10228-4:2016-07.

EUROPEAN STANDARD

**EN 10228-4**

NORME EUROPÉENNE

EUROPÄISCHE NORM

June 2016

ICS 77.040.20; 77.140.85

Supersedes EN 10228-4:1999

English Version

**Non-destructive testing of steel forgings - Part 4:  
Ultrasonic testing of austenitic and austenitic-ferritic  
stainless steel forgings**

Essais non destructifs des pièces forgées en acier -  
Partie 4: Contrôle par ultrasons des pièces forgées en  
aciers inoxydables austénitiques et austéno-ferritiques

Zerstörungsfreie Prüfung von Schmiedestücken aus  
Stahl - Teil 4: Ultraschallprüfung von Schmiedestücken  
aus austenitischem und austenitisch-ferritischem  
nichtrostendem Stahl

This European Standard was approved by CEN on 3 October 2015.

CEN members are bound to comply with the CEN/CENELEC Internal Regulations which stipulate the conditions for giving this European Standard the status of a national standard without any alteration. Up-to-date lists and bibliographical references concerning such national standards may be obtained on application to the CEN-CENELEC Management Centre or to any CEN member.

This European Standard exists in three official versions (English, French, German). A version in any other language made by translation under the responsibility of a CEN member into its own language and notified to the CEN-CENELEC Management Centre has the same status as the official versions.

CEN members are the national standards bodies of Austria, Belgium, Bulgaria, Croatia, Cyprus, Czech Republic, Denmark, Estonia, Finland, Former Yugoslav Republic of Macedonia, France, Germany, Greece, Hungary, Iceland, Ireland, Italy, Latvia, Lithuania, Luxembourg, Malta, Netherlands, Norway, Poland, Portugal, Romania, Slovakia, Slovenia, Spain, Sweden, Switzerland, Turkey and United Kingdom.



EUROPEAN COMMITTEE FOR STANDARDIZATION  
COMITÉ EUROPÉEN DE NORMALISATION  
EUROPÄISCHES KOMITEE FÜR NORMUNG

**CEN-CENELEC Management Centre: Avenue Marnix 17, B-1000 Brussels**

<b>Contents</b>	<b>Page</b>
European foreword.....	4
<b>1</b> <b>Scope</b> .....	<b>5</b>
<b>2</b> <b>Normative references</b> .....	<b>5</b>
<b>3</b> <b>Terms and definitions</b> .....	<b>5</b>
<b>4</b> <b>Mandatory information</b> .....	<b>6</b>
<b>5</b> <b>Test procedure</b> .....	<b>6</b>
<b>5.1</b> <b>General</b> .....	<b>6</b>
<b>5.2</b> <b>Form</b> .....	<b>6</b>
<b>5.3</b> <b>Content</b> .....	<b>7</b>
<b>6</b> <b>Personnel qualification</b> .....	<b>7</b>
<b>7</b> <b>Equipment and accessories</b> .....	<b>7</b>
<b>7.1</b> <b>Instrument</b> .....	<b>7</b>
<b>7.2</b> <b>Probes</b> .....	<b>7</b>
<b>7.2.1</b> <b>General</b> .....	<b>7</b>
<b>7.2.2</b> <b>Contouring</b> .....	<b>8</b>
<b>7.2.3</b> <b>Nominal frequency</b> .....	<b>8</b>
<b>7.2.4</b> <b>Normal-beam probes</b> .....	<b>8</b>
<b>7.2.5</b> <b>Angle-beam probes</b> .....	<b>8</b>
<b>7.2.6</b> <b>Dual-element probes</b> .....	<b>8</b>
<b>7.3</b> <b>Calibration blocks</b> .....	<b>8</b>
<b>7.4</b> <b>Reference blocks</b> .....	<b>8</b>
<b>7.5</b> <b>Couplant</b> .....	<b>8</b>
<b>8</b> <b>Routine calibration and checking</b> .....	<b>9</b>
<b>9</b> <b>Stage of manufacture</b> .....	<b>9</b>
<b>10</b> <b>Surface condition</b> .....	<b>9</b>
<b>10.1</b> <b>General</b> .....	<b>9</b>
<b>10.2</b> <b>Surface finish related to quality class</b> .....	<b>9</b>
<b>10.3</b> <b>As-forged surface condition</b> .....	<b>9</b>
<b>11</b> <b>Test sensitivity</b> .....	<b>10</b>
<b>11.1</b> <b>General</b> .....	<b>10</b>
<b>11.2</b> <b>Normal-beam probes</b> .....	<b>10</b>
<b>11.3</b> <b>Angle-beam probes</b> .....	<b>10</b>
<b>11.4</b> <b>Repeat testing</b> .....	<b>10</b>
<b>12</b> <b>Scanning</b> .....	<b>10</b>
<b>12.1</b> <b>General</b> .....	<b>10</b>
<b>12.2</b> <b>Complex forgings</b> .....	<b>11</b>
<b>12.3</b> <b>Grid scanning coverage</b> .....	<b>11</b>
<b>12.4</b> <b>100 % scanning coverage</b> .....	<b>11</b>
<b>12.5</b> <b>Scanning speed</b> .....	<b>11</b>
<b>13</b> <b>Classification</b> .....	<b>14</b>
<b>13.1</b> <b>Classification of indications</b> .....	<b>14</b>
<b>13.2</b> <b>Classification of discontinuities</b> .....	<b>16</b>

<b>14</b>	<b>Recording levels and acceptance criteria .....</b>	<b>19</b>
<b>15</b>	<b>Sizing .....</b>	<b>20</b>
<b>16</b>	<b>Test report .....</b>	<b>21</b>
<b>Annex A (informative) Maximum testable depth for corresponding beam path range for circumferential angle-beam scans .....</b>		
		<b>22</b>
<b>Annex B (informative) Amplitude of indication in dB relative to % DAC.....</b>		
		<b>24</b>
<b>Annex C (informative) Significant technical changes to the version EN 10228-4:1999.....</b>		
		<b>25</b>

## EN 10228-4:2016 (E)

### European foreword

This document (EN 10228-4:2016) has been prepared by Technical Committee ECISS/TC 111 “Steel castings and forgings”, the secretariat of which is held by AFNOR.

This European Standard shall be given the status of a national standard, either by publication of an identical text or by endorsement, at the latest by December 2016 and conflicting national standards shall be withdrawn at the latest by December 2016.

Attention is drawn to the possibility that some of the elements of this document may be the subject of patent rights. CEN [and/or CENELEC] shall not be held responsible for identifying any or all such patent rights.

This document supersedes EN 10228-4:1999.

Annex C provides the significant technical changes to the previous version EN 10228-4:1999.

EN 10228 consists of the following parts under the general title *Non-destructive testing of steel forgings*:

- *Part 1: Magnetic particle inspection;*
- *Part 2: Penetrant testing;*
- *Part 3: Ultrasonic testing of ferritic or martensitic steel forgings;*
- *Part 4: Ultrasonic testing of austenitic and austenitic-ferritic stainless steel forgings.*

According to the CEN-CENELEC Internal Regulations, the national standards organizations of the following countries are bound to implement this European Standard: Austria, Belgium, Bulgaria, Croatia, Cyprus, Czech Republic, Denmark, Estonia, Finland, Former Yugoslav Republic of Macedonia, France, Germany, Greece, Hungary, Iceland, Ireland, Italy, Latvia, Lithuania, Luxembourg, Malta, Netherlands, Norway, Poland, Portugal, Romania, Slovakia, Slovenia, Spain, Sweden, Switzerland, Turkey and the United Kingdom.

## 1 Scope

This European Standard describes techniques for the manual, pulse-echo, ultrasonic testing of forgings manufactured from austenitic and austenitic-ferritic stainless steels. Mechanized scanning techniques, such as immersion testing, may be used but should be agreed between the purchaser and supplier (see Clause 4).

This part of EN 10228 applies to four types of forgings, classified according to their shape and method of production. Types 1, 2 and 3 are essentially simple shapes. Type 4 covers complex shapes.

This part of EN 10228 does not apply to:

- closed die forgings;
- turbine rotor and generator forgings.

Ultrasonic testing of ferritic and martensitic steel forgings is the subject of Part 3 of this European Standard.

## 2 Normative references

The following documents, in whole or in part, are normatively referenced in this document and are indispensable for its application. For dated references, only the edition cited applies. For undated references, the latest edition of the referenced document (including any amendments) applies.

EN 1330-1, *Non-destructive testing - Terminology - Part 1: List of general terms*

EN 1330-4, *Non-destructive testing - Terminology - Part 4: Terms used in ultrasonic testing*

EN 12668-1, *Non-destructive testing - Characterization and verification of ultrasonic examination equipment - Part 1: Instruments*

EN 12668-2, *Non-destructive testing - Characterization and verification of ultrasonic examination equipment - Part 2: Probes*

EN 12668-3, *Non-destructive testing - Characterization and verification of ultrasonic examination equipment - Part 3: Combined equipment*

EN ISO 2400, *Non-destructive testing - Ultrasonic testing - Specification for calibration block No. 1 (ISO 2400)*

EN ISO 9712, *Non-destructive testing - Qualification and certification of NDT personnel (ISO 9712)*

EN ISO 16811, *Non-destructive testing - Ultrasonic testing - Sensitivity and range setting (ISO 16811)*

EN ISO 16827, *Non-destructive testing - Ultrasonic testing - Characterization and sizing of discontinuities (ISO 16827)*

## 3 Terms and definitions

For the purposes of this document, the terms and definitions given in EN 1330-1 and EN 1330-4 apply.

**EN 10228-4:2016 (E)****4 Mandatory information**

The following aspects concerning ultrasonic testing shall be agreed between the purchaser and supplier at the time of the enquiry or order:

- a) the manufacturing stage(s) at which ultrasonic testing shall be performed (see Clause 9);
- b) the volume(s) to be tested and whether grid scanning coverage or 100 % scanning coverage is required (see Clause 12);
- c) whether near surface testing is required (see 7.2.6);
- d) the quality class required, or the quality classes and the zones to which they apply (see Clause 14);
- e) the applicable recording/acceptance criteria if different from those detailed in Table 5, Table 6 or Table 7;
- f) whether any special scanning coverage, equipment or couplant is required in addition to that detailed in Clauses 7 and 12;
- g) the scanning technique to be used if not manual (see Clause 1);
- h) the sizing techniques to be used for extended discontinuities (see Clause 15);
- i) the technique(s) to be used for setting sensitivity (see Clause 11);
- j) whether the test shall be conducted in the presence of the purchaser or his representative;
- k) whether a written procedure shall be submitted for approval by the purchaser (see Clause 5);
- l) whether testing by angle-beam probes is required (see 11.3);
- m) the remaining test requirements for complex forgings (type 4) (see 12.2).

**5 Test procedure****5.1 General**

Ultrasonic testing shall be performed in accordance with a written test procedure. Where specified in the enquiry or order, the written test procedure shall be submitted to the purchaser for approval prior to the test.

**5.2 Form**

The written test procedure shall be one of the following:

- a) a product specification;
- b) a test procedure written specifically for the application;
- c) this part of EN 10228 may be used if it is accompanied by examination details specific to the application.

### 5.3 Content

The written test procedure shall contain the following details as minimum requirements:

- a) description of the forgings to be tested;
- b) reference documents;
- c) qualification of testing operator;
- d) stage of manufacture at which the test is carried out;
- e) testing zones specified in terms of the applicable quality classes;
- f) preparation of scanning surfaces;
- g) couplant;
- h) description of the test equipment;
- i) calibration and checking of the test equipment;
- j) scanning plan;
- k) description and sequence of testing operations;
- l) recording levels;
- m) characterization of discontinuities;
- n) acceptance criteria;
- o) test report.

## 6 Personnel qualification

Personnel shall be qualified in accordance with the requirements detailed in EN ISO 9712.

## 7 Equipment and accessories

### 7.1 Instrument

The ultrasonic instrument shall feature A-scan presentation and shall conform to EN 12668-1.

### 7.2 Probes

#### 7.2.1 General

Probes used for the initial detection of discontinuities shall conform to EN 12668-2. Where supplementary probes are used for purposes other than the initial detection of discontinuities, they need not conform to EN 12668-2.

## **EN 10228-4:2016 (E)**

### **7.2.2 Contouring**

When required, probes shall be contoured in accordance with EN ISO 16811.

### **7.2.3 Nominal frequency**

Probes shall have a nominal frequency in the range from 0,5 MHz to 6 MHz.

### **7.2.4 Normal-beam probes**

Effective transducer diameter shall be in the range from 10 mm to 40 mm.

### **7.2.5 Angle-beam probes**

For the transverse waves, the angle-beam probes shall be in the range from 35° to 70°.

Effective transducer area shall be in the range from 20 mm<sup>2</sup> to 625 mm<sup>2</sup>.

### **7.2.6 Dual-element probes**

If near-surface testing is required, then dual-element probes shall be used.

## **7.3 Calibration blocks**

Calibration blocks shall conform to the requirements detailed in EN ISO 2400.

## **7.4 Reference blocks**

Reference blocks shall be used when sensitivity shall be established by the distance-amplitude curve (DAC) technique and/or when discontinuities shall be sized in terms of amplitude relative to reference reflectors by the DAC technique. The surface condition of the reference block shall be representative of the surface condition of the object to be tested. Unless otherwise specified the reference block shall contain at least three reflectors covering the entire depth range being tested.

The reference block shall be manufactured from one of the following:

- a) an excess length of the object to be tested;
- b) a part of the same material and with the same heat treatment condition as the object to be tested;
- c) a part having similar acoustic properties to the object to be tested.

The choice of a test block with similar acoustic properties should be to the appreciation of a Level 2 qualified person.

Reference blocks shall not be used for the distance-gain-size (DGS) technique other than for checking the accuracy of a particular DGS diagram.

Reflector sizes different from those detailed in Tables 5 and 6 may be used as long as the test sensitivity is corrected accordingly.

## **7.5 Couplant**

The same type of couplant shall be used for the setting of range and sensitivity, for scanning and for the assessment of discontinuities.

NOTE Examples of suitable couplants are: water (with or without corrosion inhibitor or softener), grease, oil, glycerol and water cellulose paste.

After the test, couplant shall be removed if its presence could adversely affect later manufacturing or testing operations or the integrity of the test object.

## 8 Routine calibration and checking

The combined equipment (instrument and probes) shall be calibrated and checked in accordance with the requirements detailed in EN 12668-3.

## 9 Stage of manufacture

Ultrasonic testing shall be performed after the final heat treatment unless otherwise agreed at the time of enquiry or order (see Clause 4), e.g. at the latest possible stage of manufacture for areas of the forging which are not practicable to test after the final heat treatment.

For both cylindrical and rectangular forgings, which shall be bored, it is recommended to carry out ultrasonic testing before boring.

## 10 Surface condition

### 10.1 General

Surfaces to be scanned shall be free from paint, non-adhering scale, dry couplant, surface irregularities or any other substance which could reduce coupling efficiency, hinder the free movement of the probe or cause errors in interpretation.

### 10.2 Surface finish related to quality class

In the machined condition, for testing to quality classes 1 and 2, a surface finish corresponding to a roughness  $R_a \leq 12,5 \mu\text{m}$  shall be produced and for testing of quality class 3, a surface finish corresponding to a roughness  $R_a \leq 6,3 \mu\text{m}$  shall be produced.

**Table 1 — Surface finish related to quality class<sup>a</sup>**

Surface finish	Quality class and roughness $R_a$		
	1	2	3
	$\leq 12,5 \mu\text{m}$		$\leq 6,3 \mu\text{m}$
Machined	X		X
<sup>a</sup> "X" signifies the quality class that can be achieved in machined conditions.			

### 10.3 As-forged surface condition

Where forgings are supplied in the as-forged surface condition they shall be considered acceptable providing the specified quality class can be achieved. When it is not practical to perform a comprehensive test on as-forged surfaces, shot blasting, sand blasting or surface grinding shall be used to ensure that acoustic coupling can be maintained.

NOTE Only quality class 1 is normally applicable.

**EN 10228-4:2016 (E)****11 Test sensitivity****11.1 General**

Test sensitivity shall be sufficient to ensure the detection of the smallest discontinuities required by the recording levels (see Table 5 and when required, Tables 6 or 7). If the required sensitivity cannot be achieved due to coarse grain size, acceptance of the forging shall be subject to agreement between the purchaser and supplier.

**11.2 Normal-beam probes**

For normal-beam probes, one of the following techniques shall be used to establish the sensitivity for scanning:

- a) Distance-amplitude curve (DAC) technique, based upon the use of side-drilled holes (flat-bottomed holes possible);
- b) Distance-gain-size (DGS) technique (disc-shaped reflectors).

The procedure to be used in each case shall be in accordance with EN ISO 16811.

**11.3 Angle-beam probes**

For angle-beam probes one of the following techniques shall be used to establish the sensitivity for scanning:

- a) DAC technique using 3 mm diameter side-drilled holes;
- b) DGS technique (disc-shaped reflectors).

The procedure to be used in each case shall be as detailed in EN ISO 16811.

The DAC and DGS techniques shall not be compared for angle-beam probes.

**11.4 Repeat testing**

Where repeat testing is performed the same method of establishing sensitivity (DAC or DGS) shall be used as was initially used.

**12 Scanning****12.1 General**

Scanning shall be performed using the manual contact pulse-echo technique.

The minimum scanning coverage required is dictated by the type of forging and whether grid scanning coverage or 100 % scanning coverage has been specified in the enquiry or order (see Clause 4).

Table 2 classifies four types of forging according to their shapes and method of production.

Table 3 specifies the requirements for normal-beam probes for forging types 1, 2 and 3.

Table 4 specifies the requirements for angle-beam probes for forging types 3a, 3b and 3c which have an outside diameter to inside diameter ratio less than 1,6:1. The effective depth of circumferentially oriented angle-beam scans is limited by the beam angle and the forging diameter (see Annex A).

## 12.2 Complex forgings

For complex shaped forgings or complex shaped parts of forgings (type 4) and small diameter forgings, test requirements shall include, as a minimum, the required beam angles, scanning directions and extent of scanning coverage (grid or 100 %). The remaining test requirements shall be agreed between purchaser and supplier (see Clause 4, m)).

## 12.3 Grid scanning coverage

Grid scanning shall be performed with the probe or probes traversed along the grid lines defined in Tables 3 and 4.

Where recordable indications are revealed by grid scanning, additional scanning shall be performed to determine the extent of the indications.

## 12.4 100 % scanning coverage

100 % scanning coverage shall be performed over the surfaces specified in Tables 3 and 4. Consecutive probe traverses shall overlap by at least 10 % of the effective beam diameter.

## 12.5 Scanning speed

Manual scanning speed shall not exceed 150 mm/s.

## EN 10228-4:2016 (E)

Table 2 — Classification of forgings according to their shape and method of production

Type	Shape	Method of production
1a <sup>a</sup>	Elongated with round or approximately round section, e.g. bars, rods, cylinders, shafts, journals, discs cut from bars 	Direct forged
1b <sup>a</sup>	Elongated with rectangular or approximately rectangular section, e.g. bars, rods, blocks, sections cut from bars 	
2 <sup>b</sup>	Flattened, e.g. discs, plate, flywheels 	Upset
3a	Hollow cylindrical shapes, e.g. bottles, compressed gas tanks 	Mandrel forged
3b	Hollow cylindrical shapes, e.g. rings, flanges, rims 	Expanded
3c		Ring rolling
4	All forgings or parts of forgings with complex shape	At the manufacturer's discretion
<sup>a</sup> Type 1 forgings may incorporate bores of small diameter relative to the major dimensions. <sup>b</sup> Type 2 forgings may eventually be drilled (e.g. binding discs).		

Table 3 — Scanning coverage with normal-beam probes

Type		Grid scanning <sup>a</sup>		100 % Scanning <sup>a, b</sup>
1	1a	Diameter, $D$ , (mm)	Scan lines <sup>c</sup>	Scan 100 % around at least 180° of cylindrical surface
		$D \leq 200$ $200 < D \leq 500$ $500 < D \leq 1\,000$ $1\,000 < D$	2 at 90° 3 at 60° 4 at 45° 6 at 30°	
	1b	Scan along the lines of a square-link grid on two perpendicular surfaces <sup>c, d</sup>		Scan 100 % on two perpendicular surfaces
				
2		Scan along the lines of a square-link grid around 360° on the cylindrical surface and one lateral surface <sup>d</sup>		Scan 100 % around at least 180° on the cylindrical surface and 100 % of one lateral surface
3	3a	Scan along the lines of a square-link grid around 360° on the outer cylindrical surface <sup>d</sup>		Scan 100 % around 360° on the outer cylindrical surface
				
	3b and 3c	Scan along the lines of a square-link grid around 360° on the outer cylindrical surface and one lateral surface <sup>d</sup>		Scan 100 % around 360° on the outer cylindrical surface and one lateral surface
				
4	Scanning coverage shall be specified in the enquiry or order			
<sup>a</sup> Additional scanning (for example in both axial directions for type 3a) may be carried out if specified in the enquiry or order. <sup>b</sup> 100 % means at least 10 % beam overlap between consecutive probe traverses. <sup>c</sup> For types 1a or 1b, if the presence of a bore prevents the opposite surface being reached, the number of scan lines shall be doubled symmetrically. <sup>d</sup> The grid line separation shall be equal to the part thickness, up to a maximum of 200 mm.				

Table 4 — Scanning coverage with angle-beam probes

Type		Grid scanning <sup>a</sup>	100 % scanning <sup>a, b</sup>
3 <sup>c</sup>	3a  3b 	Scan in both directions along 360° circumferential grid lines, the separation of which is equal to the radial thickness up to a maximum of 200 mm	Scan in both circumferential directions over 100 % on the outer cylindrical surface
4	Scanning coverage shall be specified in the enquiry or order		
<sup>a</sup> Additional scanning coverage may be carried out if specified in the enquiry or order. <sup>b</sup> 100 % means at least 10 % beam overlap between consecutive probe traverses. <sup>c</sup> For forgings type 3c this test procedure is normally not used, but it may be agreed at time of enquiry.			

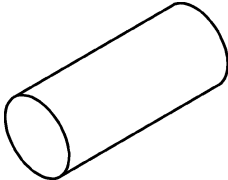
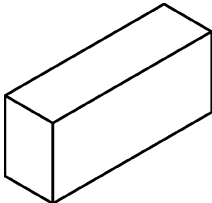
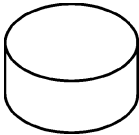
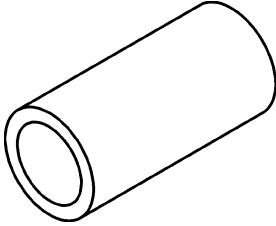
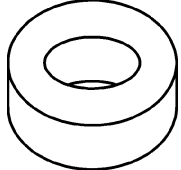
## 13 Classification

### 13.1 Classification of indications

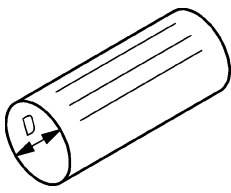
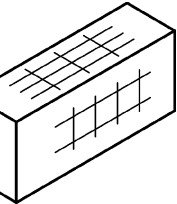
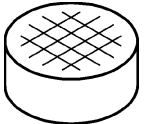
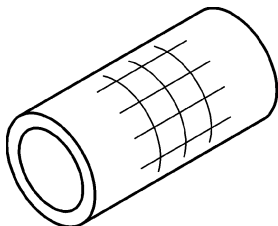
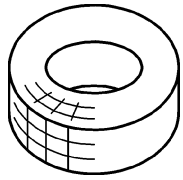
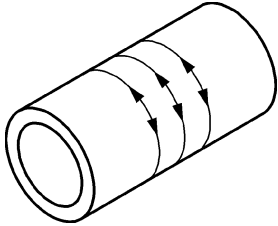
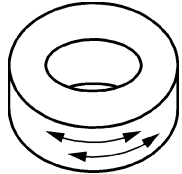
Where practicable, classification of indications according to their echodynamic pattern shall be made by scanning from a minimum of two mutually perpendicular directions.

#### a) Pattern 1:

As the probe is moved, the A-scan display shows a single sharp indication rising smoothly in amplitude to a maximum and then falling smoothly to zero (see Figure 1a)).

This A-scan display in combination with the echodynamic pattern in Figure 1b) obtained from the side-drilled holes used to plot the beam profile, corresponds to discontinuity dimensions smaller than or equal to the -6 dB beam profile.

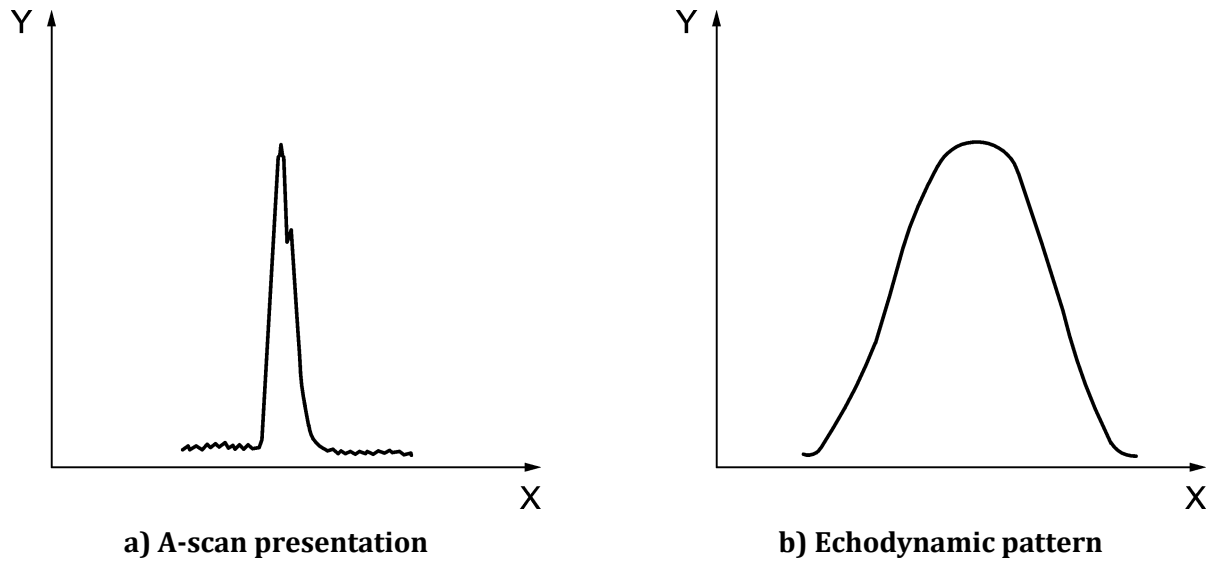
**Key**

- a) X pattern of A-Scan at fixed probe position (at typical probe position)
- b) X pattern of curve amplitude against probe shift (variation in signal amplitude as probe is moved)
- Y amplitude

**Figure 1 — Pattern 1 - A-scan presentation and echo envelope presentation**

## b) Pattern 2:

As the probe is moved, the A-scan display shows a single sharp indication rising smoothly in amplitude to a maximum and then falling smoothly to zero (see Figure 2 a)). This A-scan display in combination with the echodynamic pattern in Figure 2 b) obtained from the side-drilled holes used to plot the beam profile, corresponds to discontinuity dimensions greater than the to  $-6$  dB beam profile.

## EN 10228-4:2016 (E)

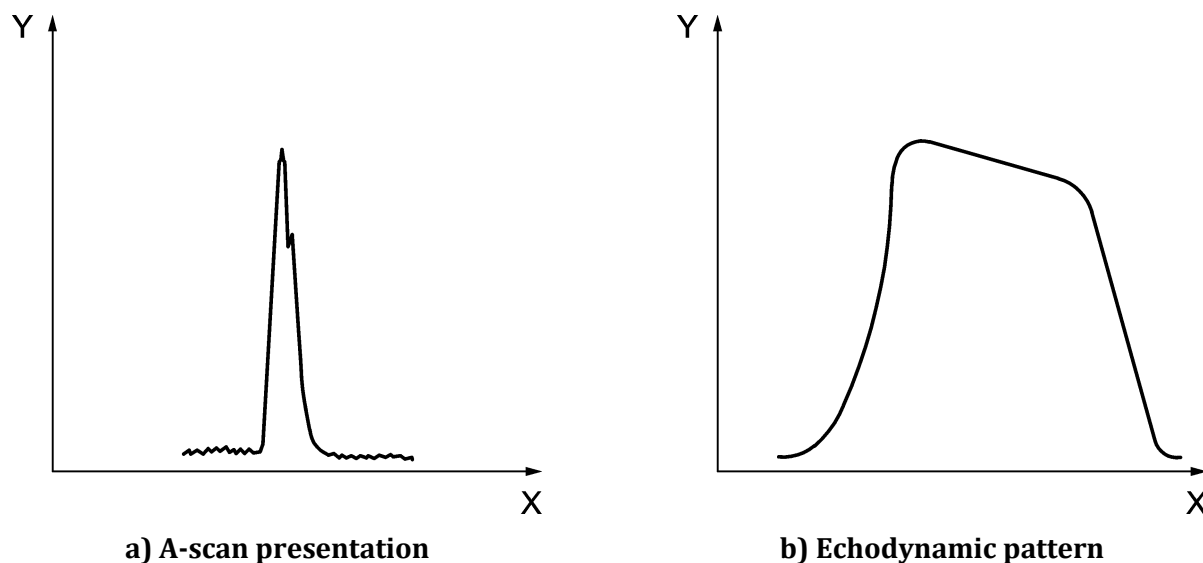
**Key**

- a) X pattern of A-Scan at fixed probe position (at typical probe position)  
 b) X pattern of curve amplitude against probe shift (variation in signal amplitude as probe is moved)  
 Y amplitude

**Figure 2 — Pattern 2 - A-scan presentation and echo envelope presentation**

### 13.2 Classification of discontinuities

Discontinuities shall be classified according to their echodynamic patterns as follows:

- a) Point-like discontinuity:

Echodynamic pattern 1 and/or dimension equal to or less than the  $-6$  dB beam width (see Figure 3).

- b) Extended discontinuity:

Echodynamic pattern 2 and/or dimension greater than the  $-6$  dB width (see Figure 4).

- c) Isolated discontinuities:

The distance  $d$ , between points corresponding to the maxima of the indications of adjacent discontinuities exceeds 40 mm (see Figure 5).

- d) Grouped discontinuities:

The distance  $d$ , between points corresponding to the maxima of the indications of adjacent discontinuities is less than or equal to 40 mm (see Figure 6).

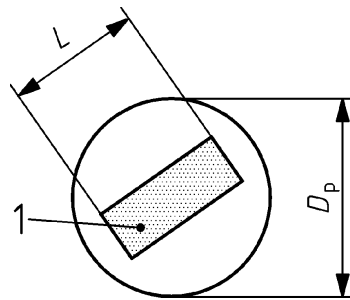
**Key**

- 1** Conventional outline of -6 dB discontinuity
- $D_p$  Width of beam at depth of discontinuity
- $L$  Conventional length of -6 dB discontinuity

**Figure 3 — Point-like discontinuity**  
**( $L \leq D_p$ )**

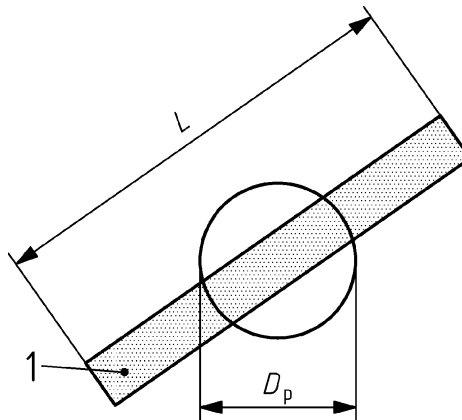
**Key**

- 1** Conventional outline of -6 dB discontinuity
- $D_p$  Width of beam at depth of discontinuity
- $L$  Conventional length of -6 dB discontinuity

**Figure 4 — Extended discontinuity**  
**( $L > D_p$ )**

## EN 10228-4:2016 (E)

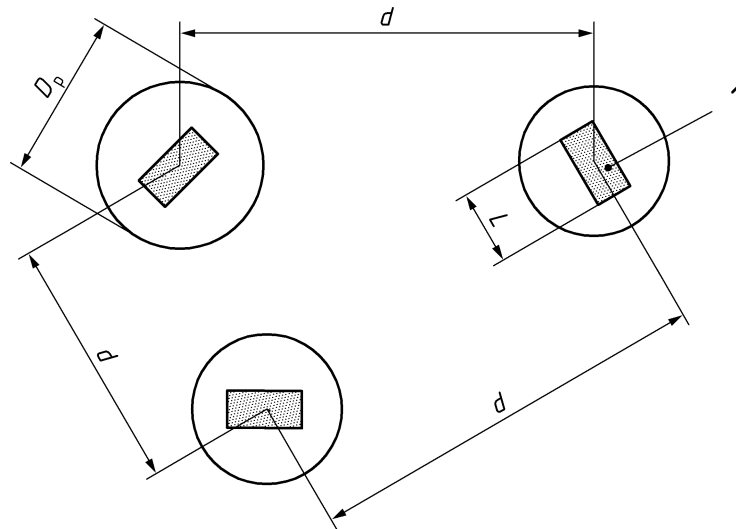
**Key**

- 1** Conventional outline of -6 dB discontinuity
- $D_p$  Width of beam at depth of discontinuity
- $d$  Distance between two discontinuities
- $L$  Conventional length of -6 dB discontinuity

**Figure 5 — Isolated discontinuities**  
 $(L \leq D_p, d > 40 \text{ mm})$

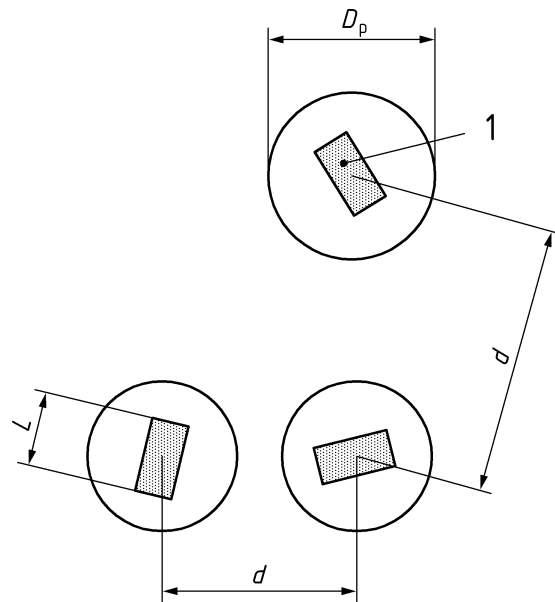
**Key**

- 1** Conventional outline of -6 dB discontinuity
- $D_p$  Width of beam at depth of discontinuity
- $d$  Distance between two discontinuities
- $L$  Conventional length of -6 dB discontinuity

**Figure 6 — Grouped discontinuities**  
 $(L \leq D_p, d \leq 40 \text{ mm})$

## 14 Recording levels and acceptance criteria

Several quality classes may be applied to a forging or to parts of a forging. The applicable quality class(es) shall be agreed between the purchaser and supplier. Table 5 details recording levels and acceptance criteria which shall be applied to three quality classes for normal-beam probes. Tables 6 and 7 detail recording levels and acceptance criteria which shall be applied for angle-beam probes.

**Table 5 — Quality classes, recording levels and acceptance criteria for normal-beam probes<sup>a</sup>**

Forging thickness $t$ mm	Recording level $d_{eq}^b$ mm	Acceptance criteria for	
		Isolated discontinuities $d_{eq}^b$ mm	Extended or grouped discontinuities $d_{eq}^b$ mm
<b>Quality class 1</b>			
$t \leq 75$	$> 5$	$\leq 8$	$\leq 5$
$75 < t \leq 250$	$> 8$	$\leq 11$	$\leq 8$
$250 < t \leq 400$	$> 14$	$\leq 19$	$\leq 14$
$t > 400$	Indication with a 80 % reduction of backwall echo	Indication with a total loss of backwall echo. A total loss of backwall echo shall be considered when its amplitude becomes less than 5 % of its initial value measured near the indication or less than or equal to grass	
<b>Quality class 2</b>			
$t \leq 75$	$> 3$	$\leq 5$	$\leq 3$
$75 < t \leq 250$	$> 5$	$\leq 8$	$\leq 5$
$250 < t \leq 400$	$> 8$	$\leq 11$	$\leq 8$
$400 < t \leq 600$	$> 11$	$\leq 15$	$\leq 11$
$t > 600$	Indication with a 80 % reduction of backwall echo	Indication with a total loss of backwall echo. A total loss of backwall echo shall be considered when its amplitude becomes less than 5 % of its initial value measured near the indication or less than or equal to grass	
<b>Quality class 3</b>			
$t < 75$	$> 2$	$\leq 3$	$\leq 2$
$75 < t \leq 250$	$> 3$	$\leq 5$	$\leq 3$
$250 < t \leq 400$	$> 5$	$\leq 8$	$\leq 5$
$400 < t \leq 600$	$> 8$	$\leq 11$	$\leq 8$
$t > 600$	Indication with a 80 % reduction of backwall echo	Indication with a total loss of backwall echo. A total loss of backwall echo shall be considered when its amplitude becomes less than 5 % of its initial value measured near the indication or less than or equal to grass	

<sup>a</sup> Reflector diameter shall not be interpreted as representing the dimension of the discontinuity which caused the echo.

<sup>b</sup>  $d_{eq}$  = Equivalent diameter of flat-bottomed hole.

## EN 10228-4:2016 (E)

Table 6 — Recording levels and acceptance criteria for angle-beam probes for DGS technique<sup>a</sup>

Forging thickness $t$ mm	Recording level $d_{eq}^a$ mm	Acceptance criteria for	
		Isolated discontinuities $d_{eq}$ mm	Extended or grouped discontinuities $d_{eq}$ mm
$t \leq 75$	$> 3$	$\leq 5$	$\leq 3$
$75 < t \leq 250$	$> 5$	$\leq 8$	$\leq 5$
$250 < t \leq 400^b$	$> 8$	$\leq 11$	$\leq 8$

<sup>a</sup>  $d_{eq}$  = Equivalent diameter of flat bottomed hole.

<sup>b</sup> For thicknesses  $> 400$  mm testing shall be as agreed between purchaser and supplier.

Table 7 — Recording levels and acceptance criteria for angle-beam probes for DAC technique<sup>a, b, c</sup>

Forging thickness $t$ mm	Nominal test frequency MHz	Recording level %	Acceptance criteria for	
			Isolated discontinuities %	Extended or grouped discontinuities %
$t \leq 75$	1	30	60	30
	2	50	100	50
$75 < t \leq 250$	1	50	100	50
	2	100	200	100
$250 < t \leq 400$	1	100	200	100
	2	200	400	200

<sup>a</sup> Based on 3 mm diameter side-drilled holes.

<sup>b</sup> A DAC based on 3 mm diameter side drilled holes shall be constructed for each frequency of probe used.

<sup>c</sup> The indication amplitude in dB, relative to the DAC, is given in Annex B.

## 15 Sizing

Where the extent of a discontinuity is required to be evaluated, one or more of the following techniques, as agreed between the purchaser and the supplier, shall be used. These techniques shall be carried out in accordance with the requirements detailed in EN ISO 16827:

- 6 dB-drop technique;
- 20 dB-drop technique;
- maximum amplitude technique.

## 16 Test report

All tests shall be the subject of a written report which shall include the following information as minimum requirements:

- a) name of supplier;
- b) order number;
- c) identification of forging(s) to be tested;
- d) scope of the test: surface areas and applicable quality classes;
- e) stage of manufacture at which ultrasonic test was performed;
- f) surface condition;
- g) equipment used (instrument, probes, calibration and reference blocks);
- h) technique(s) used to set test sensitivity;
- i) reference to this standard and, if applicable, reference to the written procedure used;
- j) test results: location, classification and amplitude (in terms of FBH-equivalent diameter, or in percent of SDH) of all discontinuities exceeding the appropriate recording level;
- k) details of any restrictions to the required scanning coverage and if applicable the extent of the (untested) near surface zone;
- l) date of the test;
- m) name, qualification, certification (if specified) and signature of the operator.

EN 10228-4:2016 (E)

## Annex A (informative)

### Maximum testable depth for corresponding beam path range for circumferential angle-beam scans

Figure A.1 and Table A.1 show the maximum testable depth  $M$  for circumferential angle-beam scans for a given probe and beam path range  $D$ .

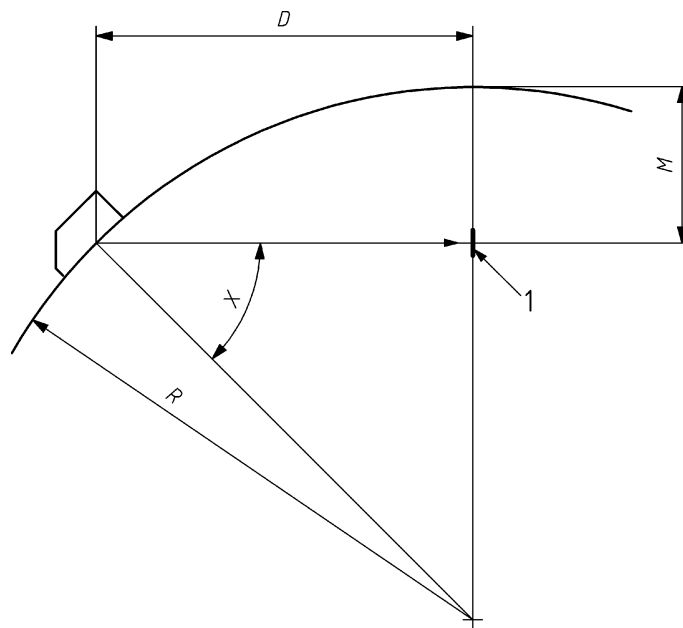

#### Key

- 1 reflector
- $D$  is the beam path range for normal incidence on a radial reflector
- $M$  is the maximum testable depth for a particular probe angle and outside radius  $R$
- $R$  outside radius
- $X$  beam angle

Regarding  $X$ ,  $M$  and  $D$ , see Table A.1 underneath.

**Figure A.1 — Maximum testable depth and corresponding beam path range for circumferential angle-beam scans**

**Table A.1 — Maximum testable depth and corresponding beam path range**

<b>Beam angle, <math>X</math></b>	<b>Maximum testable depth, <math>M</math></b>	<b>Beam path range, <math>D</math></b>
70°	0,06R	0,34R
60°	0,13R	0,50R
50°	0,24R	0,64R
45°	0,30R	0,70R
35°	0,42R	0,82R

NOTE The maximum testable depth and beam path range to this depth for radial reflectors are given in terms of the outside radius  $R$  of the forging.

EN 10228-4:2016 (E)

**Annex B**  
(informative)**Amplitude of indication in dB relative to % DAC**

As an alternative to constructing a DAC which is a percentage of the 3 mm diameter side-drilled hole DAC (100 % DAC), the required recording /acceptance level may be achieved by constructing the 3 mm DAC (100 % DAC) and adjusting the amplitude according to Table B.1.

**Table B.1 — Amplitude of indication in dB relative to % DAC**

<b>DAC</b> %	<b>Amplitude of indication relative to DAC</b> dB
25	-12
30	-10
50	-6
60	-4
100	0
200	+6
400	+12

## **Annex C**

(informative)

### **Significant technical changes to the version EN 10228-4:1999**

Some significant technical changes to the previous version EN 10228-4:1999 are listed below:

- a) Scope has been aligned with EN 10228-3;
- b) updating of the normative references;
- c) generally updating and alignment of the designations to the actual state of art;
- d) new Table 1 concerning surface finish related to quality class;
- e) statement in chapter 9 concerning stage of manufacture aligned with EN 10228-3;
- f) method of production for the types 3b and 3c in Table 2 updated;
- g) supplementary footnote c) in Table 4 concerning scanning coverage with angle-beam probes for products of type 3c);
- h) correlation between terms and Figures 1 and 2 have been updated in Clause 13;
- i) Note in Table A.1 updated.