



---

**P O L S K A N O R M A**

---

ICS 19.100

**PN-EN ISO 16811**

**Wprowadza**

EN ISO 16811:2014, IDT  
ISO 16811:2012, IDT

**Zastępuje**

PN-EN 583-2:2004

**Badania nieniszczące**

**Badania ultradźwiękowe**

**Nastawianie czułości i zakresu obserwacji**

**Norma Europejska EN ISO 16811:2014 *Non-destructive testing – Ultrasonic testing – Sensitivity and range setting (ISO 16811:2012)* ma status Polskiej Normy**

© Copyright by PKN, Warszawa 2014

nr ref. PN-EN ISO 16811:2014-06

**Wszelkie prawa autorskie zastrzeżone. Żadna część niniejszej publikacji nie może być zwielokrotniana jakkolwiek techniką bez pisemnej zgody Prezesa Polskiego Komitetu Normalizacyjnego**

ISBN 978-83-275-2957-2

## **PN-EN ISO 16811:2014-06**

### **Przedmowa krajowa**

Niniejsza norma została zatwierdzona przez Prezesa PKN dnia 2 czerwca 2014 r.

Komitetem krajowym odpowiedzialnym za normę jest KT nr 7 ds. Badań Nieniszczących.

Istnieje możliwość przetłumaczenia normy na język polski na wniosek zainteresowanych środowisk. Decyzję podejmuje właściwy Komitet Techniczny.

Niniejsza norma zastępuje PN-EN 583-2:2004.

Odpowiedniki krajowe norm i innych dokumentów powołanych w niniejszej normie można znaleźć w katalogu Polskich Norm. Oryginały norm i innych dokumentów powołanych są dostępne w PKN.

W sprawach merytorycznych dotyczących treści normy można zwracać się do właściwego Komitetu Technicznego lub właściwej Rady Sektorowej PKN, kontakt: [www.pkn.pl](http://www.pkn.pl)

### **Nota uznaniowa**

Norma Europejska EN ISO 16811:2014 została uznana przez PKN za Polską Normę PN-EN ISO 16811:2014-06.

EUROPEAN STANDARD

**EN ISO 16811**

NORME EUROPÉENNE

EUROPÄISCHE NORM

March 2014

ICS 19.100

Supersedes EN 583-2:2001

English Version

## Non-destructive testing - Ultrasonic testing - Sensitivity and range setting (ISO 16811:2012)

Essais non destructifs - Contrôle par ultrasons - Réglage de la sensibilité et de la base de temps (ISO 16811:2012)

Zerstörungsfreie Prüfung - Ultraschallprüfung - Empfindlichkeits- und Entfernungseinstellung (ISO 16811:2012)

This European Standard was approved by CEN on 9 February 2014.

CEN members are bound to comply with the CEN/CENELEC Internal Regulations which stipulate the conditions for giving this European Standard the status of a national standard without any alteration. Up-to-date lists and bibliographical references concerning such national standards may be obtained on application to the CEN-CENELEC Management Centre or to any CEN member.

This European Standard exists in three official versions (English, French, German). A version in any other language made by translation under the responsibility of a CEN member into its own language and notified to the CEN-CENELEC Management Centre has the same status as the official versions.

CEN members are the national standards bodies of Austria, Belgium, Bulgaria, Croatia, Cyprus, Czech Republic, Denmark, Estonia, Finland, Former Yugoslav Republic of Macedonia, France, Germany, Greece, Hungary, Iceland, Ireland, Italy, Latvia, Lithuania, Luxembourg, Malta, Netherlands, Norway, Poland, Portugal, Romania, Slovakia, Slovenia, Spain, Sweden, Switzerland, Turkey and United Kingdom.



EUROPEAN COMMITTEE FOR STANDARDIZATION  
COMITÉ EUROPÉEN DE NORMALISATION  
EUROPÄISCHES KOMITEE FÜR NORMUNG

**CEN-CENELEC Management Centre: Avenue Marnix 17, B-1000 Brussels**

**EN ISO 16811:2014 (E)**

<b>Contents</b>	<b>Page</b>
Foreword.....	<b>3</b>

## **Foreword**

The text of ISO 16811:2012 has been prepared by Technical Committee ISO/TC 135 “Non-destructive testing” of the International Organization for Standardization (ISO) and has been taken over as EN ISO 16811:2014 by Technical Committee CEN/TC 138 “Non-destructive testing” the secretariat of which is held by AFNOR.

This European Standard shall be given the status of a national standard, either by publication of an identical text or by endorsement, at the latest by September 2014, and conflicting national standards shall be withdrawn at the latest by September 2014.

Attention is drawn to the possibility that some of the elements of this document may be the subject of patent rights. CEN [and/or CENELEC] shall not be held responsible for identifying any or all such patent rights.

This document supersedes EN 583-2:2001.

According to the CEN-CENELEC Internal Regulations, the national standards organizations of the following countries are bound to implement this European Standard: Austria, Belgium, Bulgaria, Croatia, Cyprus, Czech Republic, Denmark, Estonia, Finland, Former Yugoslav Republic of Macedonia, France, Germany, Greece, Hungary, Iceland, Ireland, Italy, Latvia, Lithuania, Luxembourg, Malta, Netherlands, Norway, Poland, Portugal, Romania, Slovakia, Slovenia, Spain, Sweden, Switzerland, Turkey and the United Kingdom.

### **Endorsement notice**

The text of ISO 16811:2012 has been approved by CEN as EN ISO 16811:2014 without any modification.



# INTERNATIONAL STANDARD

**ISO**  
**16811**

First edition  
2012-04-01

---

---

## **Non-destructive testing — Ultrasonic testing — Sensitivity and range setting**

*Essais non destructifs — Contrôle par ultrasons — Réglage de la  
sensibilité et de la base de temps*



Reference number  
ISO 16811:2012(E)

© ISO 2012

**ISO 16811:2012(E)**



**COPYRIGHT PROTECTED DOCUMENT**

© ISO 2012

All rights reserved. Unless otherwise specified, no part of this publication may be reproduced or utilized in any form or by any means, electronic or mechanical, including photocopying and microfilm, without permission in writing from either ISO at the address below or ISO's member body in the country of the requester.

ISO copyright office  
Case postale 56 • CH-1211 Geneva 20  
Tel. + 41 22 749 01 11  
Fax + 41 22 749 09 47  
E-mail [copyright@iso.org](mailto:copyright@iso.org)  
Web [www.iso.org](http://www.iso.org)

Published in Switzerland

# Contents

Page

Foreword .....	V
Introduction .....	vi
1 Scope .....	1
2 Normative references .....	1
3 General .....	1
3.1 Quantities and symbols .....	1
3.2 Test objects, reference blocks and reference reflectors .....	1
3.3 Categories of test objects .....	1
3.4 Contouring of probes .....	2
3.4.1 Longitudinally curved probes .....	3
3.4.2 Transversely curved probes .....	3
3.4.3 Concave scanning surface .....	4
4 Determination of probe index and beam angle .....	4
4.1 General .....	4
4.2 Flat probes .....	4
4.2.1 Calibration block technique .....	4
4.2.2 Reference block technique .....	4
4.3 Probes curved longitudinally .....	4
4.3.1 Mechanical determination .....	4
4.3.2 Reference Block Technique .....	6
4.4 Probes curved transversely .....	6
4.4.1 Mechanical determination .....	6
4.4.2 Reference block technique .....	7
4.5 Probes curved in two directions .....	8
4.6 Probes for use on materials other than non-alloy steel .....	9
5 Time base setting .....	9
5.1 General .....	9
5.2 Reference blocks and reference reflectors .....	9
5.3 Straight beam probes .....	10
5.3.1 Single reflector technique .....	10
5.3.2 Multiple reflector technique .....	10
5.4 Angle beam probes .....	10
5.4.1 Radius technique .....	10
5.4.2 Straight beam probe technique .....	10
5.4.3 Reference block technique .....	10
5.4.4 Contoured probes .....	10
5.5 Alternative range settings for angle beam probes .....	11
5.5.1 Flat surfaces .....	11
5.5.2 Curved surfaces .....	11
6 Sensitivity setting and echo height evaluation .....	13
6.1 General .....	13
6.2 Angle of impingement .....	13
6.3 Distance Amplitude Curve (DAC) technique .....	13
6.3.1 Reference blocks .....	13
6.3.2 Preparation of a Distance Amplitude Curve .....	14
6.3.3 Evaluation of signals using a Distance Amplitude Curve .....	15
6.3.4 Evaluation of signals using a reference height .....	15
6.4 Distance Gain Size (DGS) technique .....	16
6.4.1 General .....	16
6.4.2 Reference blocks .....	18
6.4.3 Use of DGS diagrams .....	18
6.4.4 Restrictions on use of the DGS technique due to geometry .....	20

**ISO 16811:2012(E)**

<b>6.5</b>	<b>Transfer correction</b> .....	<b>20</b>
<b>6.5.1</b>	<b>General</b> .....	<b>20</b>
<b>6.5.2</b>	<b>Fixed path length technique</b> .....	<b>20</b>
<b>6.5.3</b>	<b>Comparative technique</b> .....	<b>21</b>
<b>6.5.4</b>	<b>Compensation for local variations in transfer correction</b> .....	<b>22</b>
<b>Annex A</b>	<b>(normative) Quantities and symbols</b> .....	<b>23</b>
<b>Annex B</b>	<b>(normative) Reference blocks and reference reflectors</b> .....	<b>26</b>
<b>Annex C</b>	<b>(normative) Determination of sound path distance and impingement angle in concentrically curved objects</b> .....	<b>29</b>
<b>C.1</b>	<b>Impingement angle</b> .....	<b>29</b>
<b>C.2</b>	<b>Sound path when scanning from the outer (convex) surface:</b> .....	<b>29</b>
<b>C.2.1</b>	<b>Full skip</b> .....	<b>30</b>
<b>C.2.2</b>	<b>Half skip</b> .....	<b>30</b>
<b>C.3</b>	<b>Soundpath when scanning from the inner (concave) surface:</b> .....	<b>31</b>
<b>C.3.1</b>	<b>Full skip</b> .....	<b>31</b>
<b>C.3.2</b>	<b>Half skip</b> .....	<b>32</b>
<b>Annex D</b>	<b>(informative) General DGS diagram</b> .....	<b>33</b>
<b>D.1</b>	<b>Distance</b> .....	<b>33</b>
<b>D.2</b>	<b>Gain</b> .....	<b>33</b>
<b>D.3</b>	<b>Size</b> .....	<b>34</b>
<b>Annex E</b>	<b>(informative) Determination of contact transfer correction factors</b> .....	<b>35</b>
<b>E.1</b>	<b>General</b> .....	<b>35</b>
<b>E.2</b>	<b>Measurement</b> .....	<b>35</b>
<b>E.3</b>	<b>Evaluation</b> .....	<b>35</b>
<b>Bibliography</b>	.....	<b>38</b>

## Foreword

ISO (the International Organization for Standardization) is a worldwide federation of national standards bodies (ISO member bodies). The work of preparing International Standards is normally carried out through ISO technical committees. Each member body interested in a subject for which a technical committee has been established has the right to be represented on that committee. International organizations, governmental and non-governmental, in liaison with ISO, also take part in the work. ISO collaborates closely with the International Electrotechnical Commission (IEC) on all matters of electrotechnical standardization.

International Standards are drafted in accordance with the rules given in the ISO/IEC Directives, Part 2.

The main task of technical committees is to prepare International Standards. Draft International Standards adopted by the technical committees are circulated to the member bodies for voting. Publication as an International Standard requires approval by at least 75 % of the member bodies casting a vote.

Attention is drawn to the possibility that some of the elements of this document may be the subject of patent rights. ISO shall not be held responsible for identifying any or all such patent rights.

ISO 16811 was prepared by Technical Committee ISO/TC 135, *Non-destructive testing*, Subcommittee SC 3, *Ultrasonic testing*.

## ISO 16811:2012(E)

### Introduction

This International Standard is based on EN 583-2:2001, *Non-destructive testing — Ultrasonic examination — Part 2: Sensitivity and range setting*.

The following International Standards are linked.

ISO 16810, *Non-destructive testing — Ultrasonic testing — General principles*

ISO 16811, *Non-destructive testing — Ultrasonic testing — Sensitivity and range setting*

ISO 16823, *Non-destructive testing — Ultrasonic testing — Transmission technique*

ISO 16826, *Non-destructive testing — Ultrasonic testing — Examination for discontinuities perpendicular to the surface*

ISO 16827, *Non-destructive testing — Ultrasonic testing — Characterization and sizing of discontinuities*

ISO 16828, *Non-destructive testing — Ultrasonic testing — Time-of-flight diffraction technique as a method for detection and sizing of discontinuities*

# Non-destructive testing — Ultrasonic testing — Sensitivity and range setting

## 1 Scope

This International Standard specifies the general rules for setting the timebase range and sensitivity (i. e. gain adjustment) of a manually operated ultrasonic flaw detector with A-scan display in order that reproducible measurements may be made of the location and echo height of a reflector.

It is applicable to techniques employing a single contact probe with either a single or twin transducers, but excludes the immersion technique and techniques employing more than one probe.

## 2 Normative references

The following referenced documents are indispensable for the application of this document. For dated references, only the edition cited applies. For undated references, the latest edition of the referenced document (including any amendments) applies.

ISO 2400, *Non-destructive testing — Ultrasonic testing — Specification for calibration block No. 1*

ISO 7963, *Non-destructive testing — Ultrasonic testing — Specification for calibration block No. 2*

EN 12668-3, *Non-destructive testing — Characterization and verification of ultrasonic examination equipment — Part 3: Combined equipment*

## 3 General

### 3.1 Quantities and symbols

A full list of the quantities and symbols used throughout this International Standard is given in Annex A.

### 3.2 Test objects, reference blocks and reference reflectors



Requirements for geometrical features of test objects, reference blocks and reference reflectors in general are contained in Annex B.

### 3.3 Categories of test objects

The requirements for range and sensitivity setting will depend on the geometrical form of the test object. Five categories of test objects are defined in Table 1.

## ISO 16811:2012(E)

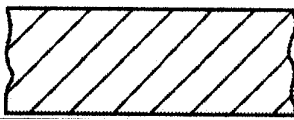
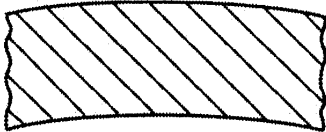
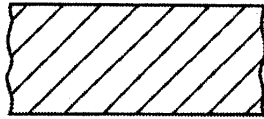
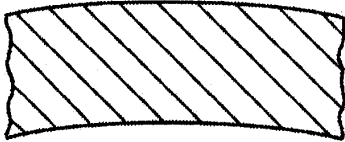
Table 1 — Categories of test objects

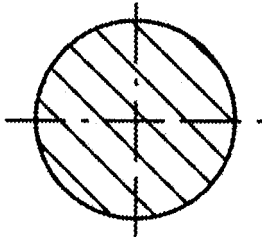
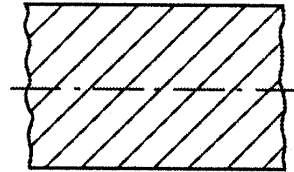
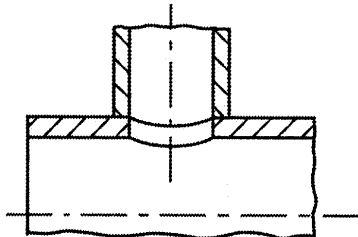
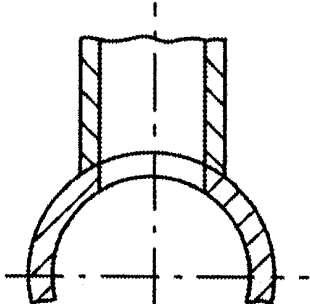
Class	Feature	Section in $x$ -direction	section in $y$ -direction
1	Plane parallel surfaces (e. g. plate/sheet)		
2	Parallel, uniaxially curved surfaces (e. g. tubes)		
3	Parallel surfaces curved in more than one direction (e. g. dished ends)		
4	Solid material of circular cross section (e. g. rods and bars)		
5	Complex shapes (e. g. nozzles, sockets)		

## 3.4 Contouring of probes

Contouring of the probe shoe, for geometry categories 2 to 5, may be necessary to avoid probe rocking, i.e. to ensure good, uniform, acoustic contact and a constant beam angle in the test object. Contouring is only possible with probes having a hard plastic stand-off (normally twin-transducer straight beam probes or angle beam probes with wedges).

The following conditions for the different geometric categories exist (see Table 1 and Figure 1):

- category 1: No probe contouring necessary for scanning in either  $x$ - or  $y$ -direction;
- categories 2 and 4: scanning in  $x$ -direction: Probe face longitudinally curved, scanning in  $y$ -direction: Probe face transversely curved;
- categories 3 and 5: scanning in either  $x$ - or  $y$ -direction: Probe face longitudinally and transversely curved.

The use of contoured probes necessitates setting the range and sensitivity on reference blocks contoured similar to the test object, or the application of mathematical correction factors.

When using equations (1) or (2), problems due to low energy transmission or beam misalignment are avoided.

### 3.4.1 Longitudinally curved probes

#### 3.4.1.1 Convex scanning surface

For scanning on convex surfaces the probe face shall be contoured when the diameter of the test object,  $D_{obj}$ , is below ten times the length of the probe shoe,  $l_{ps}$ , (see Figure 1):

$$D_{obj} < 10l_{ps} \quad (1)$$

#### 3.4.1.2 Concave scanning surface

On a concave scanning surface the probe face shall always be contoured, unless adequate coupling can be achieved due to very large radii of curvature.

### 3.4.2 Transversely curved probes

#### 3.4.2.1 Convex scanning surface

For scanning on convex surfaces the probe face shall be contoured when the diameter of the test object,  $D_{obj}$ , is below ten times the width of the probe shoe,  $w_{ps}$ , (see Figure 1):

$$D_{obj} < 10w_{ps} \quad (2)$$

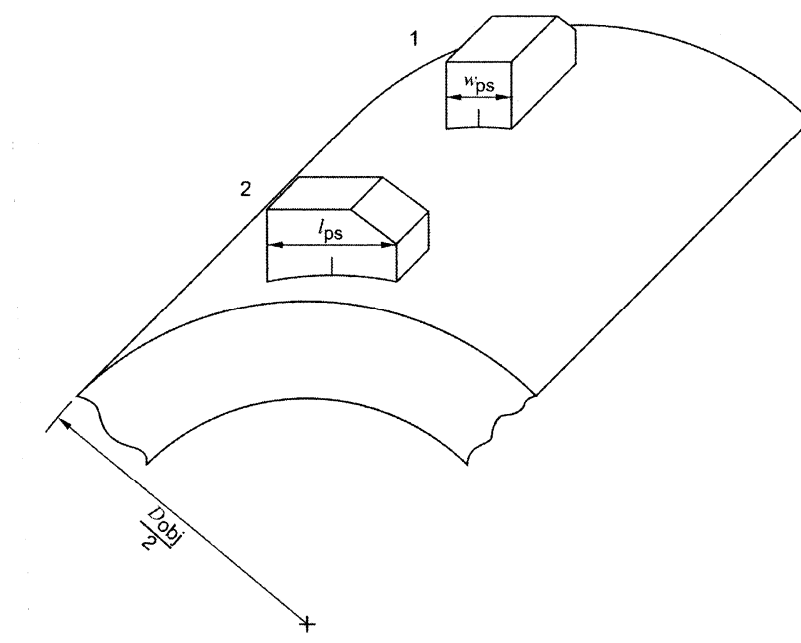

#### Key

- 1 Transversely curved
- 2 Longitudinally curved

**Figure 1 — Length,  $l_{ps}$ , and width,  $w_{ps}$ , of probe shoe in direction of curvature of the test object**

**ISO 16811:2012(E)****3.4.2.2 Concave scanning surface**

On a concave scanning surface the probe face shall always be contoured, unless adequate coupling can be achieved due to very large radii of curvature

**3.4.3 Concave scanning surface**

The probe face shall fulfil the requirements of 3.4.1 and 3.4.2.

**4 Determination of probe index and beam angle****4.1 General**

For straight beam probes there is no requirement to measure probe index and beam angle as it is assumed that the probe index is in the centre of the probe face and the angle of refraction is zero degrees.

When using angle probes, these parameters shall be measured in order that the position of a reflector in the test object can be determined in relation to the probe position. The techniques and reference blocks employed depend on the contouring of the probe face.

Measured beam angles depend on the sound velocity of the reference block used. If the block is not made of non-alloy steel its velocity shall be determined and recorded.

**4.2 Flat probes****4.2.1 Calibration block technique**

Probe index and beam angle shall be determined using Calibration Block No. 1 or Calibration Block No. 2 according to the specifications given in ISO 2400 or ISO 7963 respectively, depending on the size of the probe.

**4.2.2 Reference block technique**

An alternative technique using a reference block containing at least 3 side-drilled holes as given in EN 12668-3 may be used.

**4.3 Probes curved longitudinally****4.3.1 Mechanical determination**

Before contouring the probe face, the probe index and beam angle shall be measured as described in 4.2.1.

The incident angle at the probe face ( $\alpha_d$ ) shall be calculated from the measured beam angle ( $\alpha$ ) and a line, originating from the probe index and parallel to the incident beam, shall be marked on the side of the probe, as shown in Figure 2.

The incident angle is given by equation 3:

$$\alpha_d = \arcsin\left(\frac{c_d}{c_t} \sin \alpha\right) \quad (3)$$

where

$c_d$  is the longitudinal wave velocity in the probe wedge (normally 2730 m/s for acrylic glass)

$c_t$  is the transverse wave velocity in the test object (3255 m/s  $\pm$  15 m/s for non-alloy steel).

After contouring, the probe index will have moved along the marked line, and its new position can be measured by mechanical means directly on the probe housing, as shown in Figure 2.

The beam angle shall be determined by maximizing the echo from a side-drilled hole satisfying the conditions given in annex B. The beam angle may then be measured directly on the test object, on the reference block, or on a scale drawing. See Figure 3.

Alternatively, the beam angle may be determined by calculation on the basis of the sound path length measured on the reference block by mechanical means, using equation (4). This may be accomplished together with the range setting as described in 5.4.4.

$$\alpha = \arccos \left\{ \frac{\left[ (D_{\text{SDH}} / 2)^2 + s^2 - t^2 + sD_{\text{SDH}} + tD_{\text{Obj}} \right]}{D_{\text{Obj}} [s + (D_{\text{SDH}} / 2)]} \right\} \quad (4)$$

The symbols used in this equation are illustrated in Figure 3.

The radius of curvature of the surface used for the calibration shall be within  $\pm 10\%$  of that of the test object.

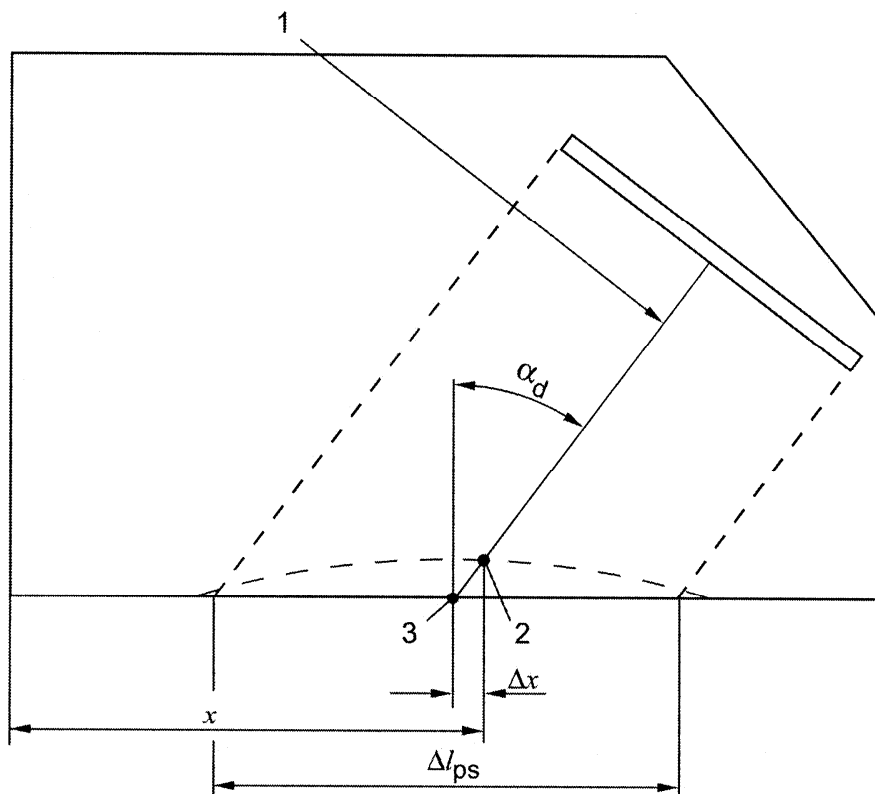

### Key

- 1 Marked line for index shift
- 2 Index point after contouring
- 3 Index point before contouring

Figure 2 — Determination of index shift for longitudinally curved probes

## ISO 16811:2012(E)

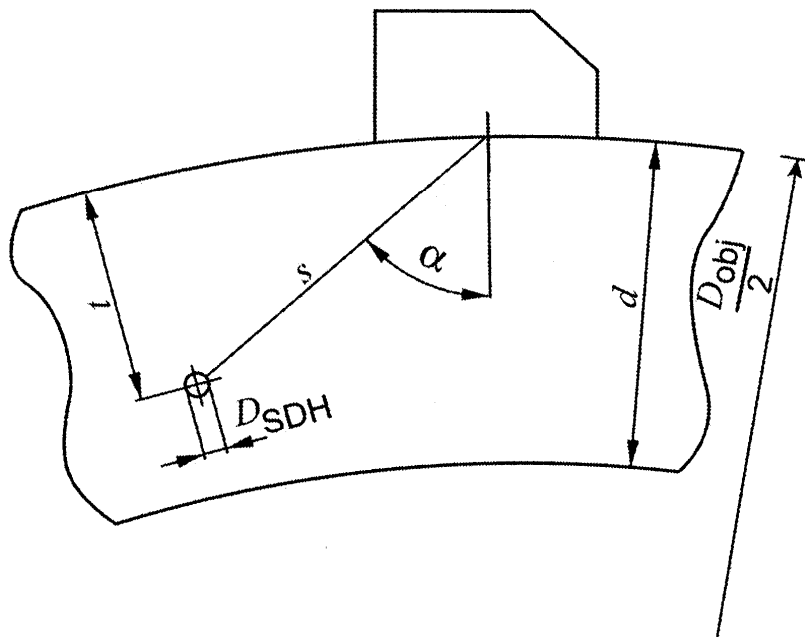

Figure 3 — Determination of beam angle  $\alpha$  for a longitudinally contoured probe

#### 4.3.2 Reference Block Technique

This is similar to that referenced in 4.2.2, except that the test block shall have a radius of curvature within  $\pm 10\%$  of that of the test object.

#### 4.4 Probes curved transversely

##### 4.4.1 Mechanical determination

Before contouring the probe face the probe index and beam angle shall be measured as described in 4.2.

After contouring, either

- i) a line representing the incident beam, originating from the probe index, shall be marked on the side of the probe. The new position of the probe index shall be measured on the side of the probe as shown in Figure 4;
- ii) the shift in probe index position ( $\Delta x$ ) shall be calculated using equation 5:

$$\Delta x = g \tan(\alpha_d) \quad (5)$$

The symbols in this equation are illustrated in Figure 4.

For acrylic glass wedges ( $c_d=2730$  m/s) and non-alloy steel test objects ( $c_t=3255$  m/s) the shift in the probe index position ( $\Delta x$ ), for the three most commonly used beam angles, shall be read from Figure 5 in relation to the depth of contouring ( $g$ ).

The beam angle should not change during contouring.

However, if it is not known, or there is any variation in the depth of contouring along the length of the probe, it shall be measured on a suitably contoured reference block using a side drilled hole satisfying the conditions given in Annex B. The beam angle shall be determined by:

- iii) drawing a straight line between the hole and the probe index on a scale drawing; or
- iv) calculation using, for example, equation (6) for the setup illustrated in Figure 6.

$$\alpha = \arctan \left[ \frac{A' + x - q}{t} \right]$$

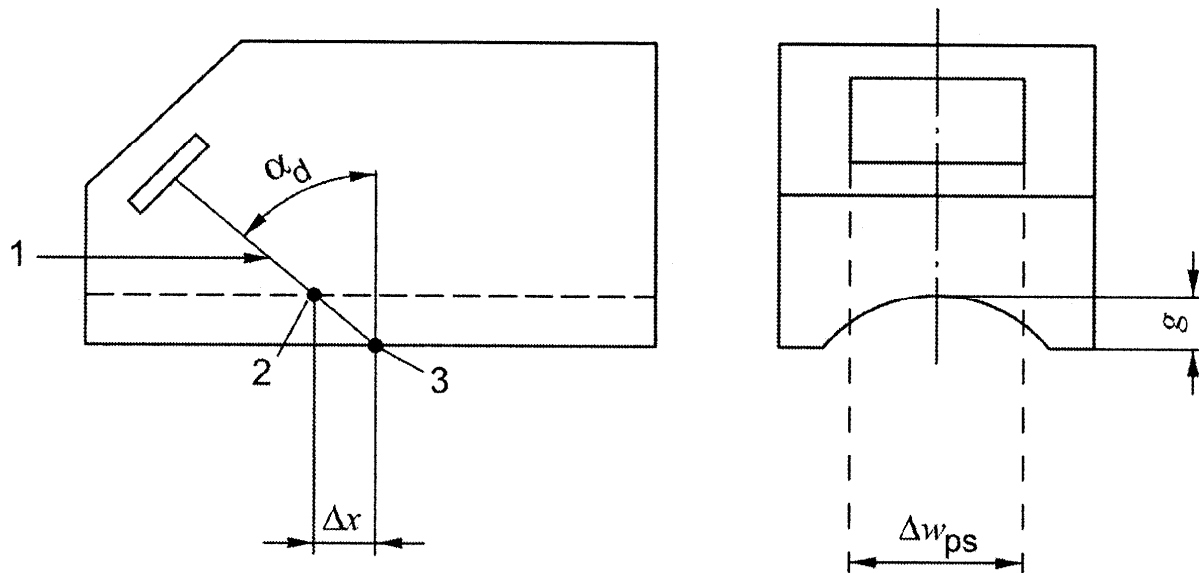

#### Key

- 1 Marked line for index shift
- 2 Index point after contouring
- 3 Index point before contouring

**Figure 4 — Determination of index shift for transversely curved probes**

#### 4.4.2 Reference block technique

This technique is similar to that referenced in 4.2.2 except that the test block shall be curved transversely in relation to the probe, and shall have a radius of curvature not exceeding 10 % greater, or 30 % lower, than that of the test object.

## ISO 16811:2012(E)

Figure 5 — Probe index shift,  $\Delta x$ , for delay paths in acrylic glass

Figure 6 — Determination of beam angle using a side-drilled hole

## 4.5 Probes curved in two directions

Unless the need for multiaxial curving of the probe face can be avoided, e. g. by use of smaller probes, the procedures specified in 4.2, 4.3 and 4.4 shall be followed as appropriate.

#### 4.6 Probes for use on materials other than non-alloy steel

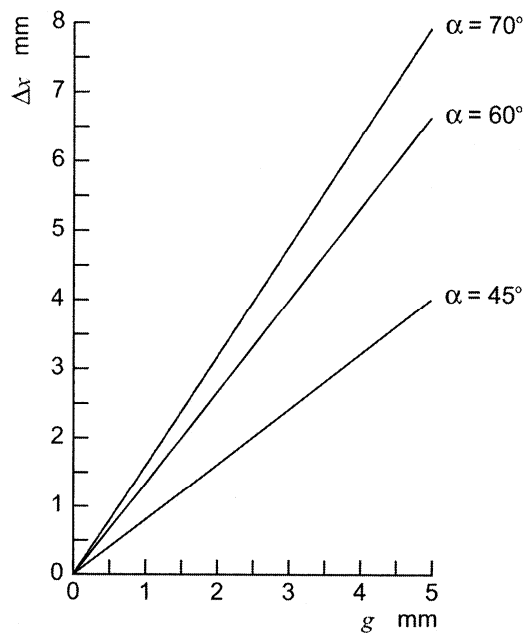
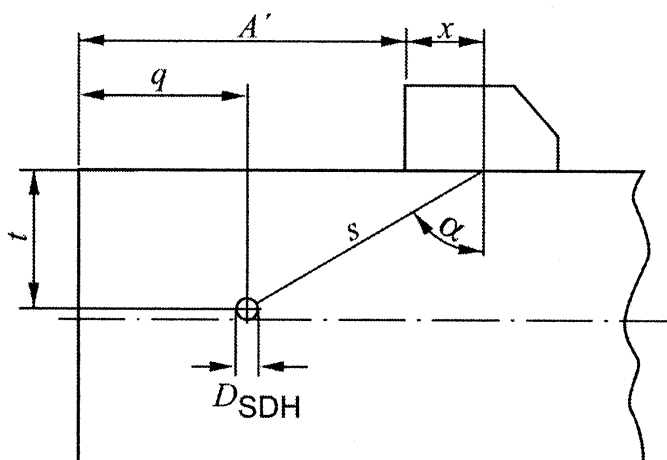
If the sound velocity in the material under test is markedly different from that in non-alloy steel, the position of the probe index and the beam angle will be significantly changed. The use of the radii on Calibration Block No. 1 or Calibration Block No. 2 may lead to confusing results.

If the sound velocity is known, the beam angle can be calculated as follows:

$$\alpha_t = \arcsin \left( \frac{c_t}{c_r} \sin \alpha_r \right) \quad (7)$$

where

$\alpha_r$  is the beam angle in a non-alloy steel reference block;

$\alpha_t$  is the beam angle in the test object;

$c_t$  is the transverse wave velocity in the test object;

$c_r$  is the transverse wave velocity in the non-alloy steel reference block (3255 m/s  $\pm$  15 m/s).

If the sound velocity is not known, the beam angle can be determined using an echo from a side-drilled hole in a sample of the material, as illustrated in Figure 6, or as described in 4.3.1 or in 4.4.1, as appropriate.

### 5 Time base setting

#### 5.1 General

For all tests using the pulse echo technique, the timebase of the ultrasonic instrument shall be set to indicate, on the screen, the sound propagation time, or, more usually, some parameters directly related to it. Such parameters may be the sound path length of a reflector, its depth below the test surface, its projection distance, or its reduced  $L_a$ , projection distance, see Figure 7. Unless otherwise noted, the procedures described below refer to setting the timebase in terms of the sound path length (an echo travels this path twice).

Timebase setting shall be carried out with two reference echoes having a known time or distance interval between them. Depending on the intended calibration, the respective sound paths, depths, projection distances, or reduced projection distances shall be known.

This technique ensures that correction is automatically made for the sound propagation time through the delay block (e. g. probe wedge). Only in the case of equipment employing an electronically calibrated timebase is one echo sufficient, provided the sound velocity of the reference block is known.

The distance between the reference echoes shall be as large as practicable within the timebase range. The left-hand rising edge of each echo shall be set, using the timebase shift and expansion controls, to correspond to a predetermined position along the horizontal screen graticule.

Where appropriate calibration shall comprise a check signal, which shall not coincide with either one of the setting signals, but shall appear at the calculated screen position.

#### 5.2 Reference blocks and reference reflectors

For the examination of ferritic steels the use of Calibration block No. 1 or Calibration block No. 2 as specified in ISO 2400 and ISO 7963, respectively, is recommended. If a reference block or the test object itself is used for calibration, faces opposite to the test surface or appropriate reflectors at different known sound path lengths may be used as applicable.

## ISO 16811:2012(E)

Reference blocks shall either have a sound velocity within  $\pm 5\%$  of that of the test object, or correction for the velocity difference shall be made.

### 5.3 Straight beam probes

#### 5.3.1 Single reflector technique

This requires a reference block having a thickness not greater than the timebase range to be set. Suitable back wall echoes may be obtained from the 25 mm or 100 mm thickness of Calibration Block No. 1, or the 12,5 mm thickness of Calibration Block No. 2.

Alternative reference blocks, having parallel or concentric surfaces, known thickness, and the same sound velocity as the test object, may also be used.

#### 5.3.2 Multiple reflector technique

This requires a reference block (or separate blocks) having two reflectors (e. g. side-drilled holes) at different known sound path lengths.

The probe shall be repeatedly repositioned to maximize the echo from each reflector; the position of the echo of the nearest reflector shall be adjusted using the shift (or zero) control and that of the echo of the other reflector using the expansion (or distance) control until an accurate timebase setting is achieved.

### 5.4 Angle beam probes

#### 5.4.1 Radius technique

Range setting can be performed using the radii reflectors of Calibration Block No. 1 or Calibration Block No. 2, as described in ISO 2400 or ISO 7963 respectively.

#### 5.4.2 Straight beam probe technique

For transverse wave probes the range setting can be carried out using a longitudinal straight beam probe on the 91 mm thickness of Calibration Block No. 1 (described in ISO 2400), corresponding to a sound path length of 50 mm for transverse waves in steel.

To complete the range setting it is necessary to obtain an echo, with the probe to be used for examination, from a suitable reflector at a known sound path distance, and using the zero shift control only, to position this echo at the correct location along the timebase.

#### 5.4.3 Reference block technique

This is similar in principle to that described in 5.3.2 for straight beam probes.

However to achieve adequate accuracy it is necessary to mark the beam index points on the surface of the block at which each echo is first maximized, and then mechanically measure the distance between these marks and the corresponding reflectors. For all subsequent timebase adjustments, the probe shall be repositioned on these marks.

#### 5.4.4 Contoured probes

Range setting shall first be performed using a probe with a flat face, as described above.

The contoured probe shall then be positioned on a suitable contoured reference block having at least one reflector at a known sound path length. The position of the echo from this reflector is adjusted to the correct position along the timebase using only the shift control.

## 5.5 Alternative range settings for angle beam probes

### 5.5.1 Flat surfaces

Instead of setting in terms of sound path length, the timebase may be set to indicate directly the depth of a reflector below the test surface, or its distance in front of the probe, see Figure 7.

Therefore, having selected the timebase in terms of depth or projection distance, the echoes from the reference block, at known sound path lengths, are set along the timebase at the positions corresponding to the equivalent depths, or projection distances, which may be determined as follows:

For a flat plate they may be determined for a given beam angle, either from a scale drawing, or from the following equations:

— depth ( $t$ ):

$$t = s \cos \alpha_t \quad (8)$$

— projection distance ( $a$ ):

$$a = s \sin \alpha_t \quad (9)$$

— shortened projection distance ( $a'$ ):

$$a' = (s \sin \alpha_t) - x \quad (10)$$

### 5.5.2 Curved surfaces

Whilst the same principles of range setting described in 5.5.1 still apply, the timebase is not linear with respect to depth or projection distance.

A non-linear graticule scale may be constructed by taking measurements at a number of positions on a scale drawing of the sound path, or by calculation using suitable equations. The sound path distance to the opposite surface of a concentrically curved object may be determined using the equations given in Annex C.

Alternatively, the graticule intervals may be determined on the basis of the maximized echoes from a series of reflectors in a curved reference block, the intermediate values being obtained by interpolation. See Figure 8.

ISO 16811:2012(E)

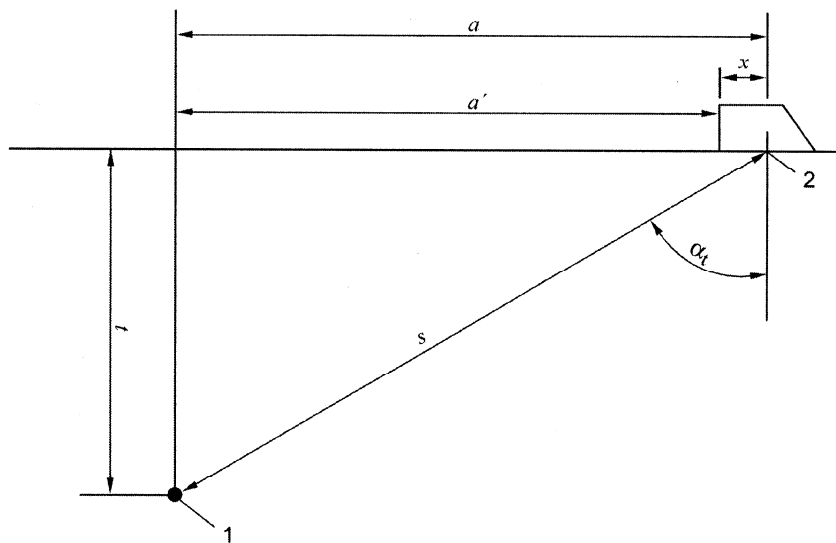

Key

- 1 Reflector
- 2 Index point

Figure 7 — Definitions for setting of the timebase in terms of e. g. reduced projection distance

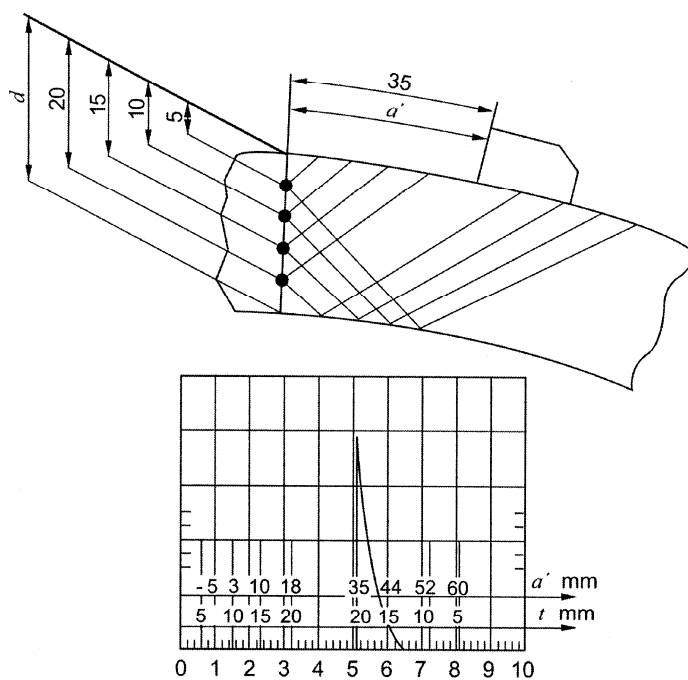

Figure 8 — Example of screen graticule for location of reflectors with a time base set in terms of reduced projection distance and depth (Here:  $\alpha_t = 51^\circ$ ,  $s_{\max} = 100$  mm)

## 6 Sensitivity setting and echo height evaluation

### 6.1 General

After the timebase has been calibrated, the sensitivity (or gain adjustment) of the ultrasonic equipment shall be set using one of the following techniques:

- 2) Single Reflector technique  
A single reference reflector e.g. a back wall, or a notch, may be used when evaluating echoes occurring within the same range of sound path distance.
- 3) Distance Amplitude Curve (DAC)-technique  
This technique uses the echo heights from a series of identical reflectors (e.g. side-drilled holes or flat-bottom holes) at different sound path lengths in suitable reference blocks (see 6.3).
- 4) Distance Gain Size (DGS)-technique  
This technique uses a series of theoretically derived curves relating the sound path length, the equipment gain, and the size of a disk-shaped reflector perpendicular to the beam axis (see 6.4).

Techniques 2 and 3 attempt to compensate for the change in the echo height from a reflector with increasing sound path distance. However, for all three techniques, a transfer correction shall be applied, where necessary, to compensate for any coupling losses and differences in material attenuation (see 6.5).

Using ideal reflectors of simple shape, e. g. side-drilled holes or flat bottom holes, for sizing of natural discontinuities will not give the true size but only an equivalent value. The true size of the real discontinuity may be much larger than this equivalent value.

### 6.2 Angle of impingement

When using angle probes on curved test objects in conjunction with indirect scanning (i. e. after the ½ skip position), the incident angle at the back wall, i. e. the angle of impingement, should be considered. In the case of cylindrical components scanned from the outer surface, the incident angle at the inner surface may be very much larger than the beam angle. Conversely, when scanning from the inner surface the incident angle at the outer surface may be very much smaller than the beam angle (see Annex C).

For transverse wave probes, the beam angle shall be chosen to avoid impingement angles outside the range 35° to 70°, because in that case severe loss in sound energy will occur due to mode conversion. Moreover, additional echoes from other wave modes may disturb echo evaluation.

A technique for determining the impingement angle at the inner and outer surfaces of a cylinder is described in Annex C together with methods of calculating the sound path distance to the opposite surface.

### 6.3 Distance Amplitude Curve (DAC) technique

#### 6.3.1 Reference blocks

A DAC reference block is required having a series of reflectors at different sound path distances over the timebase range to be used for the test. Details of the spacing and minimum size of block and reflectors are given in Annex B.

The specifications given in Annex B apply for category 1 objects, and, where appropriate, for category 2 to category 5 test objects.

It should be noted that there are minimum sound path lengths below which signals cannot be satisfactorily evaluated due to e. g. dead zone effects or near field interference.

The DAC reference block shall be either:

**ISO 16811:2012(E)**

- 1) a general purpose block of uniform low attenuation and specified surface finish, and having a thickness within  $\pm 10\%$  of the test object; or
- 2) a block of the same acoustic properties, surface finish, shape and curvature as the test object.

In the case of type 1), correction for any differences in attenuation, curvature and coupling losses may be necessary before the Distance Amplitude Curve can be directly applied.

**6.3.2 Preparation of a Distance Amplitude Curve**

The distance amplitude curve shall be either shown directly on the screen of the instrument, or plotted on a separate graph, as described below. This may be supported by electronic means. When using equipment with Time Controlled Gain, TCG, (also known as 'Swept Gain'), gain will be controlled such that the DAC will become a straight horizontal line.

**6.3.2.1 Plotting on screen**

The timebase is first calibrated to accommodate the maximum sound path length to be used, and the gain is adjusted so that the echoes from the series of reflectors fall within 20 % and 80 % of full screen height (FSH). In the case of angle probes, the reflectors may be used in either the 0 to  $\frac{1}{2}$  skip, or  $\frac{1}{2}$  to 1 skip positions.

The position of the tip of each maximized echo, at a constant gain setting, is then marked on the screen, and the Distance Amplitude Curve drawn through the points.

If the difference in height between the largest and smallest echoes exceeds the range 20 % to 80 % FSH, the line shall be split, and separate curves plotted at different gain settings (see Figure 9). The difference in gain between the two curves shall be recorded on the screen.

The gain setting used for plotting the DAC may be referenced to the echo from some other reflector, e. g. in the case of flat probes to either the 100 mm radius quadrant, or the 3 mm diameter hole in Calibration Block No. 1. This will enable the gain to be reset, in future, without the use of the reference block.

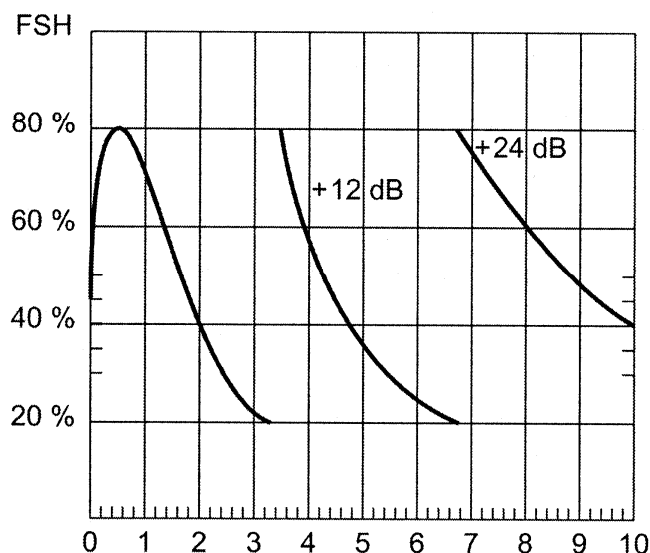

**Figure 9 — Screen of ultrasonic instrument showing a split Distance Amplitude Curve (DAC)**

### 6.3.2.2 Plotting on a separate graph

The general procedure is similar to technique 6.3.2.1 except that the maximized echo from each reflector is adjusted to the same height (generally 80 % FSH) and the gain setting noted and plotted against the sound path length on a separate graph.

### 6.3.2.3 Transfer correction

After determining transfer differences using the data obtained under 6.5, the Distance Amplitude Curve, as produced to 6.3.2.1 and 6.3.2.2, shall be corrected accordingly.

This may be achieved by either:

- 1) correcting the DAC during its preparation;
- 2) drawing a second, corrected, DAC;
- 3) applying appropriate correction values in the evaluation process.

While techniques 1 and 2 may be preferable if a sound path dependent attenuation correction is needed, technique 3 may be more suitable in cases where allowance is required only for a constant transfer correction.

## 6.3.3 Evaluation of signals using a Distance Amplitude Curve

### 6.3.3.1 Setting the test sensitivity

The test sensitivity shall be set by maximizing the echo from one of the reference reflectors in the DAC reference block and adjusting the gain to bring the peak of the echo up to the DAC.

The gain shall then be increased by the transfer correction at the appropriate sound path length, if it has not been incorporated in the DAC itself (methods 1 and 2 in 6.3.2.3).

Alternatively, if the gain setting for the Distance Amplitude Curve has been referenced to another reflector, this may be used instead, using the appropriate gain correction.

The gain is then increased (or decreased) prior to scanning by the value specified in the relevant standard or procedure.

### 6.3.3.2 Measurement of echo height

The height of any echo which requires to be evaluated is adjusted using the calibrated gain control, to bring it to the DAC, and recorded in terms of the increase or decrease in gain setting compared to the original value at which the DAC was plotted. If not already incorporated in the DAC, appropriate values for transfer correction shall be added if necessary.

Evaluation of the resulting echo height difference is as follows:

Where the gain setting has required to be increased from the original value by  $x$  dB, the echo height is assigned a value (reference level  $-x$ ) dB. Where the gain setting has required to be decreased from the original value by  $y$  dB, the echo height is assigned a value (reference level  $+y$ ) dB.

## 6.3.4 Evaluation of signals using a reference height

In this method the discontinuity echo is compared to the echo from a reference reflector having the same or larger sound path length. The two signals are set to equal screen height (i. e. the reference height), using gain settings  $V_u$  and  $V_r$ , respectively. The reference height shall be within 40 % and 90 % FSH. The echo height difference,  $\Delta H_u$ , shall then be calculated using equation 11:

**ISO 16811:2012(E)**

$$\Delta H_u = V_r - V_u \quad (11)$$

**6.4 Distance Gain Size (DGS) technique****6.4.1 General**

The DGS technique uses the theoretically derived distance amplitude curves of disk-shaped reflectors to evaluate the echo height of unknown reflectors.

In the general DGS diagram, distance and reflector size are normalized. Therefore, it is independent of probe (element) size and frequency. It shows distance as multiples of the near field length  $N_{\text{eff}}$  of the probe, and reflector sizes as multiples of the probe element diameter  $D_{\text{eff}}$  (see Figure 10 and Annex D).

From this general DGS diagram special DGS diagrams, for common types of probes, are derived for steel which allow the direct reading of equivalent reflector size without calculation (see Figure 11).

The echo height from a reflector is recorded in terms of either:

- i) the number of dB above or below the DGS curve for a specified reflector diameter, or
- ii) the diameter of a disk-shaped reflector that would give the same echo height under ideal conditions and at the same sound path distance (equivalent dis\).

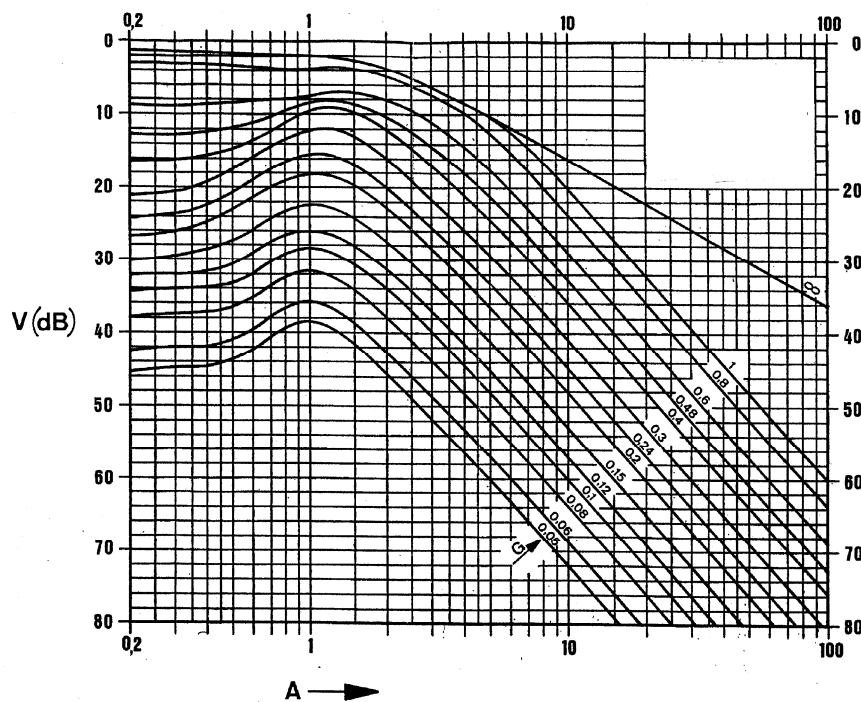

**Key**

- A* normalized distance
- V* gain in dB
- G* normalized reflector size

**Figure 10 — General DGS Diagram**

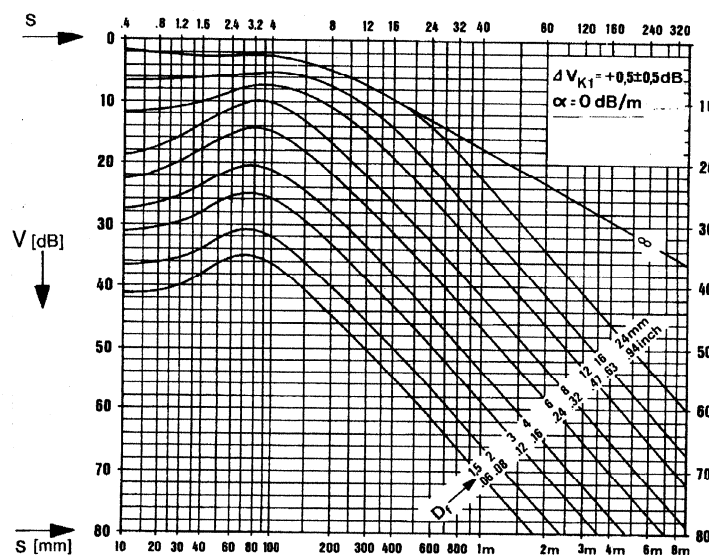

**Key**

- S* reflector distance
- V* gain in dB
- D<sub>f</sub>* reflector diameter

**Figure 11 — Specific DGS Diagram for an angle beam probe on steel**

## ISO 16811:2012(E)

### 6.4.2 Reference blocks

When using the DGS technique for setting the test sensitivity, or recording echo height, an applicable reference block, as specified in Annex B, shall be employed. This is in order to relate the gain values shown in the DGS diagram to the echo height from a suitable reference reflector. The test block may possibly be used as the reference block.

Reference blocks for angle probes shall be large enough to permit the through-transmission measurements to be made necessary for determining transfer loss. All test surfaces of the reference blocks shall have the same finish.

Concave cylindrical surfaces (e. g. the quadrants of Calibration Block No. 1 and Calibration Block No. 2 as specified in ISO 2400 or in ISO 7963) shall be employed for the calibration of sensitivity by the DGS method, only if the probe specific correction factor,  $\Delta V_k$ , for these blocks is known. This is in order that compensation can be made for the difference in reflection of the quadrant compared to that of a plane back wall. If the sign

of  $\Delta V_c$  is positive it means that the gain for the examination has to be increased by that value and vice versa.

To prevent total reflection of the sound beam at the surface of a curved reference block, or test object, the diameter of curvature,  $D_{obj}$ , shall fulfil the following condition:

$$D_{obj} > D_{eff} \left( \frac{c_t}{c_d} \times \frac{1}{1 - \sin \alpha_t} \right) \quad (12)$$

where

$D_{eff}$  is the effective diameter of the transducer;

$c_t$  is the sound velocity of transverse wave in test object;

$c_d$  is the longitudinal wave velocity in delay block;

$\alpha_t$  is the beam angle.

As an example, the value of  $D_{obj}$  (steel) shall be greater than 82 mm for a 45° angle beam probe with an effective transducer diameter of 20 mm.

### 6.4.3 Use of DGS diagrams

#### 6.4.3.1 Reference height technique

The recording gain  $V_r$ , at which scanning shall be carried out, is calculated from equation 13:

$$V_r = V_j + \Delta V + \Delta V_k + \Delta V_t \quad (13)$$

where

$V_j$  is the gain setting required to set the echo from a reference reflector, meeting the requirements of Annex B, to a given reference height on the screen (not less than 20 % FSH);

$\Delta V$  is the difference in gain between the DGS curve corresponding to the minimum equivalent disk-shaped reflector (i. e. the recording level), measured at the maximum sound path length  $s_{max}$ , and the reference reflector, measured at its sound path length  $s_j$ ;

$\Delta V_k$  is a correction factor when using a concave reference reflector, (see 6.4.2);

$\Delta V_t$  is the transfer correction (see 6.5).

The height of any echo observed during scanning which meets or exceeds the reference height on the screen, shall be assessed as follows:

The gain  $V_u$  necessary to bring the echo to the reference height shall be noted. A line representing the reference height shall then be drawn on the DGS diagram, and the gain difference  $\Delta V_u = V_u - V_r$  marked off from the reference height at the corresponding sound path distance,  $s_u$  (see Figure 12). If the marked point is above the DGS curve associated with the recording limit, the echo height  $\Delta H_u$  shall be recorded in terms of the number of dB by which it exceeds the DGS curve at the same sound path distance.

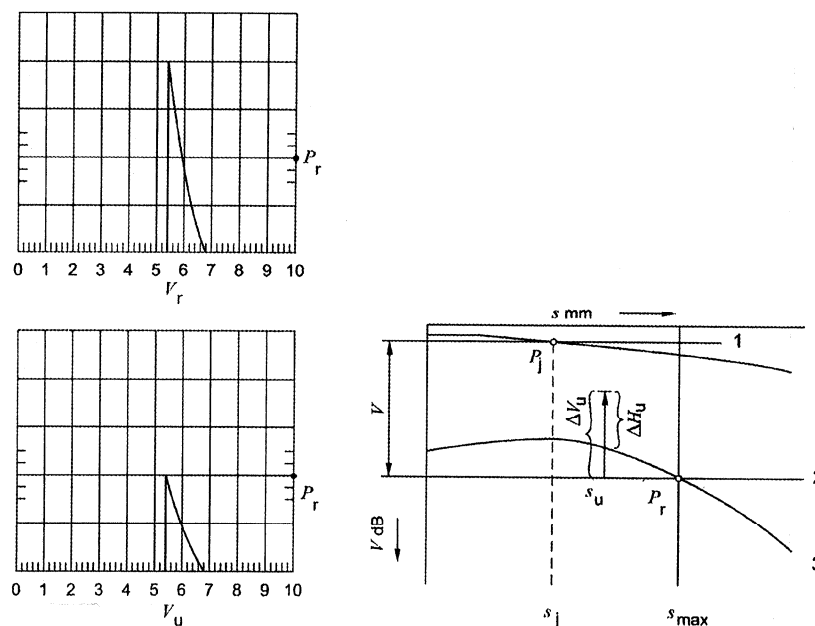

### Key

- 1 calibration height
- 2 reference height
- 3 reference line

**Figure 12 — Example of echo height evaluation using the reference height technique**

#### 6.4.3.2 Reference line technique

The curve on the DGS diagram, associated with the recording limit, shall be transferred as a reference line from the DGS diagram to the screen. Note that the relationship between the difference in gain of the DGS diagram ( $\Delta V$ ) at different sound paths is a logarithmic one, whereas the corresponding scaling on the screen is linear:

$$\Delta V \text{ (in dB)} = -20 \log_{10} \left( \frac{h_1}{h_2} \right) \quad (14)$$

where  $h_1$  and  $h_2$  are the actual physical screen heights, e. g. expressed as a percentage full screen height (FSH).

The difference in gain ( $\Delta V$ ) between the echo from the reference reflector and the DGS curve corresponding to the recording limit, at the same sound path distance, is measured on the DGS diagram.

The echo from the reference reflector is then maximized, and the gain adjusted to set the tip of the echo to a convenient height on the screen (see below).

**ISO 16811:2012(E)**

This position is marked, and the transferred DGS curve drawn through it. The reference line shall be between 20 % and 80 % full screen height. To achieve this, the reference line and recording gain may be raised or lowered within a particular section, as shown in Figure 9.

The gain is then changed for scanning by  $\Delta V$  and by the possible corrections as given in 6.4.3.1.

The height of any echo observed during scanning, equal to or exceeding the corrected DGS curve, shall be recorded in terms of either:

- a) the number of dBs that it exceeds the corrected DGS curve at the same sound path distance;
- b) the equivalent disk-shaped reflector diameter, shown on the DGS diagram, that corresponds to the difference in echo height measured in (a) above.

**6.4.4 Restrictions on use of the DGS technique due to geometry**

Echo height evaluation using the DGS method is only applicable if contouring of the probe shoe is not required, see 3.4.

The conditions given in Annex B for reference blocks, shall also apply to the relevant surfaces of the test object. For echo height evaluation, the following condition for the normalized distance  $A$  shall be satisfied (see Annex D for the calculation of  $A$ ):

$$A \geq 0,7 \quad (15)$$

With regard to the wall thickness  $d$ , conditions (16) and (17) shall also be satisfied for straight beam scanning without delay path, and for angle beam scanning respectively:

$$d > 0,7 N_{\text{eff}} \quad (N_{\text{eff}} \text{ is the effective near field length}) \quad (16)$$

$$d > 5 \lambda \quad (\lambda \text{ is the wavelength in the test object}) \quad (17)$$

**6.5 Transfer correction****6.5.1 General**

Unless the test sensitivity is set on a test block which is acoustically representative of the test object, a transfer correction shall be determined, and applied if necessary, when setting the test sensitivity or measuring the echo height of any discontinuity.

The transfer correction  $\Delta V_t$  is made up of two parameters:

- 1) one due to coupling losses at the contact surface and independent of sound path length;
- 2) one due to material attenuation and dependent on sound path length.

Two methods are described namely: a simple fixed path length method where compensation is made for coupling loss, and for attenuation at the maximum sound path length only; and a comparative method where full compensation is made for both parameters.

**6.5.2 Fixed path length technique**

This technique is only applicable where either the loss in acoustic energy due to attenuation is small compared to the coupling loss, or the reflector, whose echo height is to be measured, lies close to the back-wall of the test object.

When using a straight beam probe, the gain values required to bring the first backwall echoes from the reference block and the test object, to the same height on the screen are measured in dB ( $V_{t,t}$  and  $V_{t,r}$

respectively). When using an angle beam probe, two identical probes are employed as separate transmitter and receiver in V-formation to produce the corresponding echoes.

The theoretical difference in gain between the two echoes ( $\Delta V_s$ ), due to their different sound path lengths, shall be measured on the DGS curve for an infinite reflector, and the transfer correction ( $\Delta V_t$ ) calculated as follows:

$$\Delta V_t = V_{t,t} - V_{t,r} - \Delta V_s \quad (18)$$

### 6.5.3 Comparative technique

#### 6.5.3.1 Straight beam probe

The probe is placed on the reference block and the gain settings required to bring the first and second backwall echoes up to the same height on the screen are recorded (values  $V_{A1}$ ,  $V_{A2}$  in Figure 13). These values are then plotted against sound path length, and a line 2 drawn through them.

The probe is then repositioned on the test object and the above procedure repeated (values  $V_{B1}$  and  $V_{B2}$  and line 1 in Figure 13).

The transfer correction ( $\Delta V_t$ ) at the appropriate sound path length ( $s_u$ ) is given by the difference in gain between the two lines, see Figure 13.

Note that the slope of the line plotted through  $V_{B1}$  and  $V_{B2}$  does not give the true attenuation in the test object, since no account is taken of the losses caused by beam divergence and the energy transmitted into the probe at each multiple reflection at the examination surface. Annex E gives a method to experimentally determine those contact transfer losses at each multiple reflection.

#### 6.5.3.2 Angle beam probe

The technique is similar in principle to that for straight beam probes, except that two identical angle beam probes, operating as separate transmitter and receiver, are used. The frequency of these probes shall be the same as that of the probe(s) to be used for the examination of the test object.

The probes are positioned on the DAC reference block, first in V-formation, and then in W-formation, and the gain settings required to bring the echoes to the same height on the screen are recorded (values  $V_{A1}$  and  $V_{A2}$  respectively). The probes are then similarly positioned on the test object, and the procedure repeated (values  $V_{B1}$  and  $V_{B2}$ ). The recorded gain values are plotted against the sound path length, and lines drawn through each pair of points.

The transfer correction,  $\Delta V_t$ , is again given by the difference in gain between the two lines at the appropriate sound path length.

## ISO 16811:2012(E)

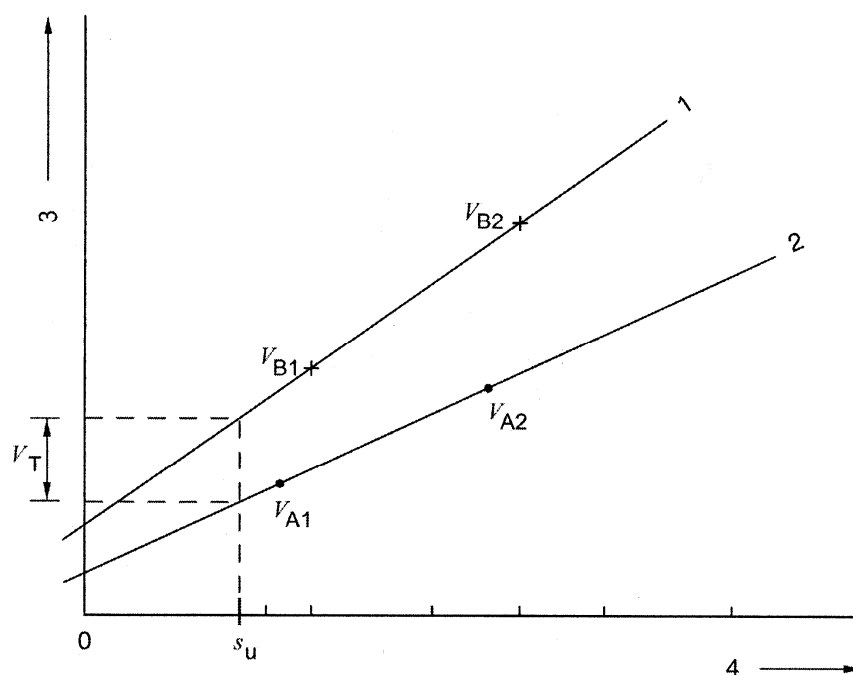
**Key**

- 1 Curve for test object
- 2 curve for reference block
- 3 gain setting for 80 % FSH
- 4 sound path length

**Figure 13 — Determination of transfer correction using the comparative method**

#### 6.5.4 Compensation for local variations in transfer correction

If there is reason to suspect local variations in transfer correction over the area of the object to be examined, the transfer correction shall be measured at a number of representative positions.

If the variation in transfer correction between the upper and lower values does not exceed 6 dB, the value to be employed shall be the average,  $\Delta V_t$ , of all the measurements made. If, however, the above variation is greater than 6 dB, methods (a) or (b) below shall be applied:

- a) increase the average transfer correction,  $\Delta V_t$ , by a value equal to the average,  $\Delta V_{\sim}$ , of all the measurements above  $\Delta V_t$ . The revised transfer correction,  $(\Delta V_t + \Delta V_{\sim})$ , shall be applied over the whole of the area to be examined;
- b) divide the area to be examined into zones, such that within each zone the variation in transfer correction does not exceed 6 dB. A separate value of  $\Delta V_t$  shall then be applied to each zone.

For oblique scanning, through transmission signals shall be employed instead of back wall echoes.

## Annex A (normative)

### Quantities and symbols

Table A.1 — Quantities and symbols

Symbol	Quantity	Unit
$A$	Normalized distance in DGS-Diagram	
$A'$	Probe co-ordinate	mm
$a$	Projection distance	mm
$a'$	Reduced projection distance	mm
$\alpha$	Measured beam angle in steel	°
$\alpha_r$	Beam angle in a non-alloy steel reference block	°
$\alpha_d$	Incident angle (beam angle in delay block)	°
$\alpha_t$	Beam angle in test object	°
$\beta$	Angle of impingement	°
$c_r$	Sound velocity in reference block	m/s
$c_t$	Velocity of transverse sound wave• in test object	m/s
$c_d$	Velocity of longitudinal sound wave• in delay block	m/s
$D_{obj}$	Outer diameter of test object or curvature of scanning surface	mm
$d$	Wall thickness	mm
$D_{eff}$	Effective diameter of transducer	mm
$D_{SSH}$	Diameter of hole with spherical bottom	mm
$D_{DSR}$	Diameter of disc shaped reflector	mm
$D_P$	Probe diameter	mm
$D_{SDH}$	Diameter of side-drilled hole	mm
$e_1$ to $e_7$	Reference block dimensions	mm

## ISO 16811:2012(E)

Table A.1 (continued)

Symbol	Quantity	Unit
$g$	Depth of contour on probe face	mm
$G$	Normalized diameter of disc shaped reflector in DGS-Diagram	
$\lambda$	Wavelength	mm
$\Delta H_u$	Echo height difference between a reference reflector and a discontinuity	dB
$l_{ps}$	Length of probe shoe in direction of curvature	mm
$l_d$	Length of delay path	mm
$\Delta l_{ps}$	Length of contoured probe face	mm
$N_{eff}$	Effective near field length	mm
$P_r$	Reference point at $s_{max}$	
$P_j$	Reference point at $s_j$	
$q$	Transverse co-ordinate of reflector	mm
$s$	Sound path length	mm
$s_j$	Sound path length of reference reflector	mm
$s_{max}$	Maximum sound path length	mm
$s_u$	Sound path length associated with evaluated signal	mm
$s_v$	Acoustic equivalent to delay path in test object	mm
$t$	Depth co-ordinate of reflector	mm

Table A.1 (continued)

Symbol	Quantity	Unit
$V$	Gain in DGS-Diagram	dB
$V_j$	Calibration basic gain	dB
$V_r$	Recording gain	dB
$V_t$	Gain for determining $\Delta V_t$	dB
$V_u$	Indication gain	dB
$\Delta V$	Gain difference	dB
$\Delta V_{\sim}$	Correction for $\Delta V_t$	dB
$\Delta V_k$	Gain correction for concave reflector	dB
$\Delta V_s$	Gain difference associated with sound path length	dB
$\Delta V_t$	Transfer correction (average)	dB
$V_{t,r}$	Gain for backwall echo on reference block	dB
$V_{t,t}$	Gain for backwall echo on test object	dB
$\Delta V_u$	Difference between indication gain and recording gain	dB
$w_{ps}$	Width of probe shoe in direction of curvature	mm
$\Delta w_{ps}$	Width of contouring of the probe face	mm
$x$	Distance between probe index and front edge of probe, for uncounted probe	mm
$\Delta x$	Probe index shift	mm

## Annex B (normative)

### Reference blocks and reference reflectors

**Table B.1 — Reference Blocks. Requirements for scanning surface, wall thickness, and back wall**

Requirements to be met by back wall examination using		
normal probe	angle probe	condition
 <p><b>Key</b> 1 Sound beam diameter</p>		$e > \frac{2\lambda s}{D_{\text{eff}}}$ $e_4, e_5 > \frac{\lambda s}{D_{\text{eff}}}$
Requirements to be met by back wall examination using:		
normal probe	angle probe	condition
		$D_{\text{SDH}} \geq 1,5\lambda$ $e > \frac{2\lambda s}{D_{\text{eff}}}$ $e_4, e_5 > \frac{\lambda s}{D_{\text{eff}}}$ $s > 1,5 N_{\text{eff}}$

Table B.1 (continued)

Requirements to be met by disc shaped reflector for examination using:		
normal probe	angle probe	condition
 <p><b>Key</b> 1 sound beam diameter</p>		$D_{DSR} < \frac{\lambda s}{D_{eff}}$ $e_4, e_5 > \frac{\lambda s}{D_{eff}}$ $s > 0,7 N_{eff}$
Requirements to be met by test surface and wall thickness for examination using:		
normal probe	angle probe	condition
		<p><math>d</math> larger than the length of the initial pulse influence zone for <math>\alpha</math> equal to <math>0^\circ</math>.</p> <p><math>d &gt; 5 \lambda</math> for <math>\alpha &gt; 0^\circ</math>.</p> <p><math>e_1 &gt; 1,5 l_{ps1}</math></p> <p><math>e_2 &gt; 1,5 l_{ps2}</math></p> <p><math>e_3 &gt; 1,5 D_{ps}</math></p>
Requirements to be met by holes with spherical bottom for examination using		
normal probe	angle probe	condition
		<p><math>s &gt; 1,5 N_{eff}</math> with</p> $D_{DSR} = \sqrt{\frac{\lambda}{\pi}} D_{SSH}$ <p><math>\beta \leq 60^\circ</math>.</p> $e_4, e_5 > \frac{\lambda s}{D_{eff}}$

Table B.2 — Reference blocks and reference reflectors for class 1 objects

Wall thickness, $d$ , in mm	Reference blocks and reference reflectors	Conditions
		
$10 \leq d \leq 15$		
$15 < d \leq 20$		$e > \frac{2\lambda_s}{D_{\text{eff}}}$
$20 < d \leq 40$		$D_{\text{SDH}} \geq 1,5\lambda$ $e_6 = \frac{d - 10}{2}$
$d > 40$		$e_7 \leq \frac{d - 10}{2}$

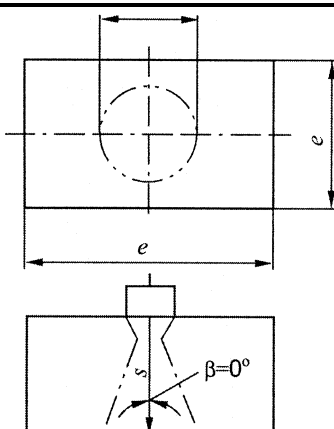
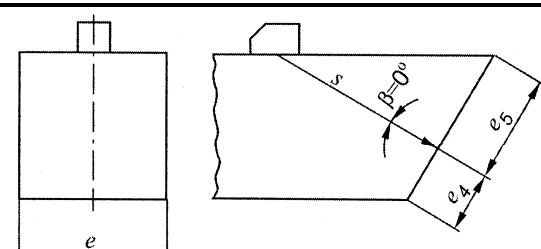
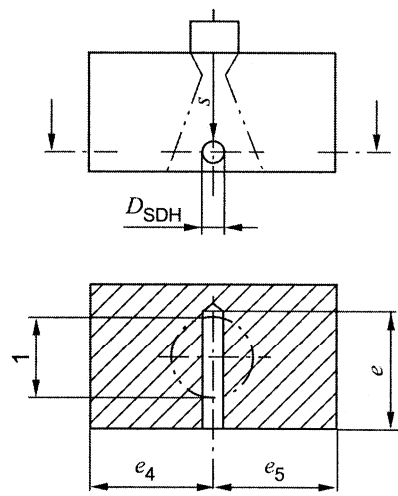
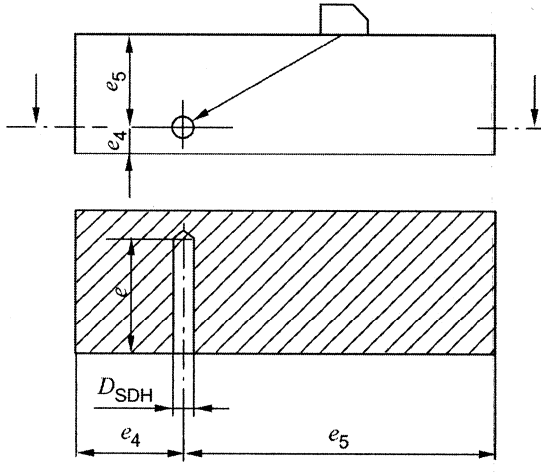
## Annex C (normative)

### Determination of sound path distance and impingement angle in concentrically curved objects

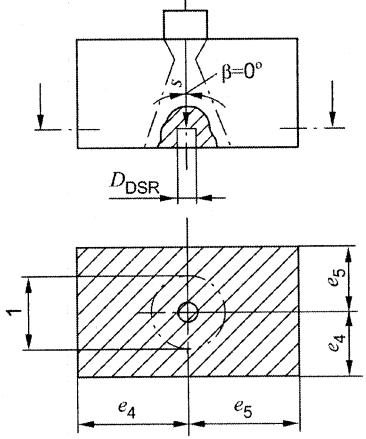
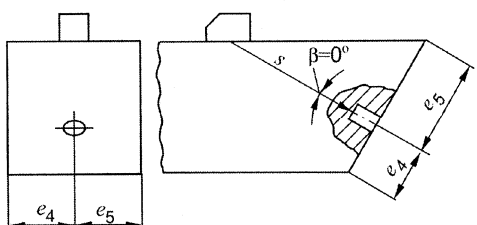
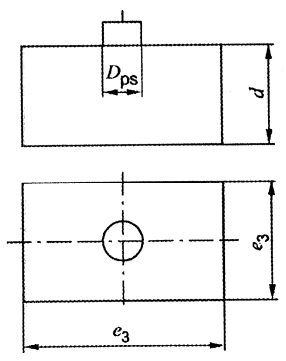
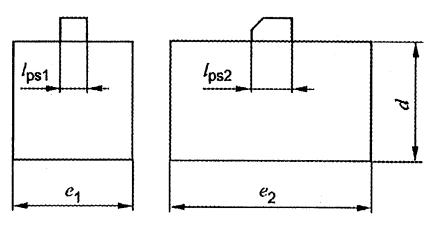
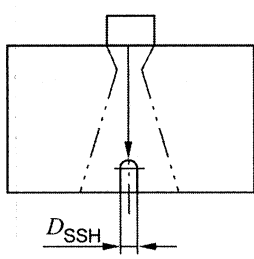
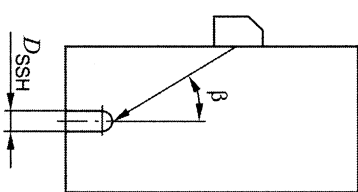
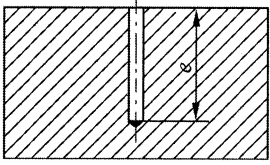
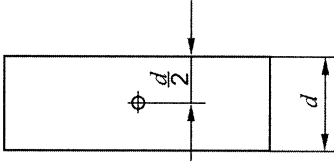
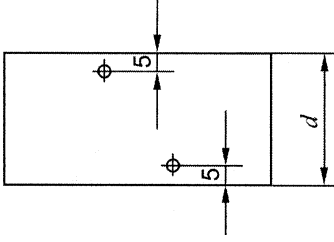
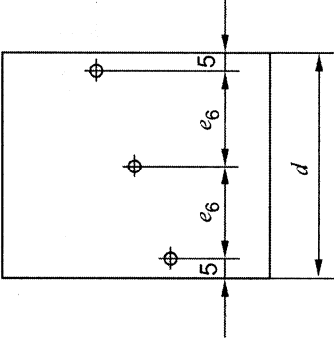
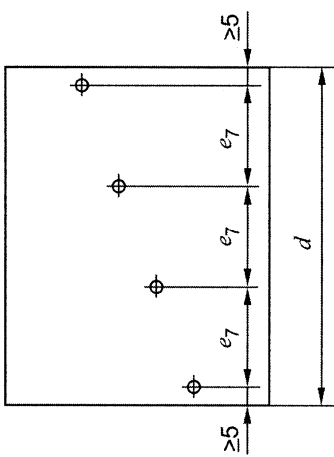
#### C.1 Impingement angle

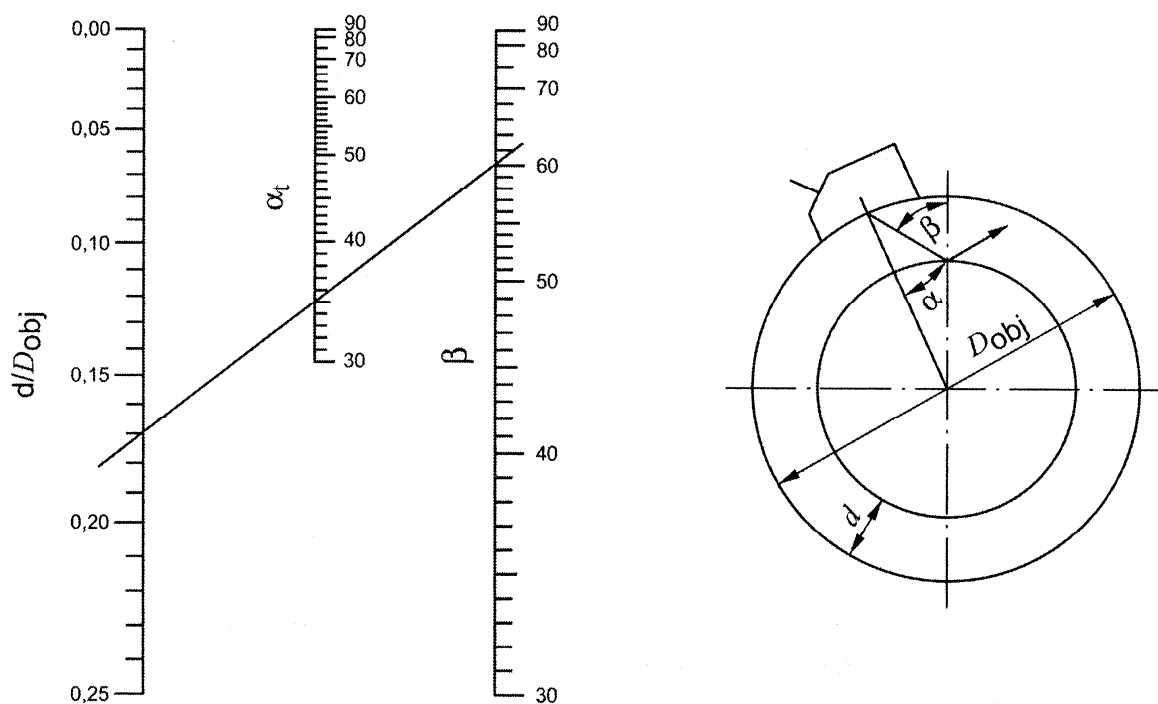

Figure C.1 — Nomogram for determination of impingement angle,  $\beta$

#### C.2 Sound path when scanning from the outer (convex) surface:

$$s = (D_{\text{obj}} \cos \alpha) - \sqrt{(D_{\text{obj}} \cos \alpha)^2 - 4d(D_{\text{obj}} - d)} \quad (\text{C.1})$$

## ISO 16811:2012(E)

## C.2.1 Full skip

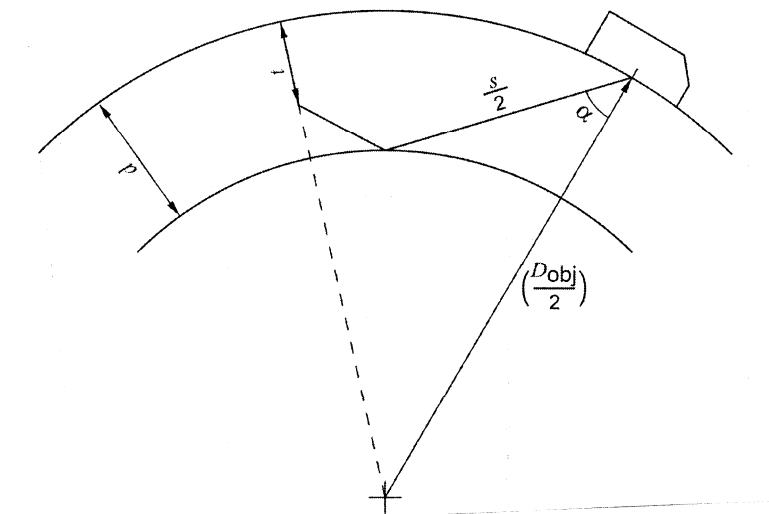

Figure C.2 — Determination of sound path distance for scanning from the outer surface in full skip

$$s_t = \left(1 - \left(\frac{t}{2d}\right)\right) \left[ (D_{\text{obj}} \cos \alpha) - \sqrt{(D_{\text{obj}} \cos \alpha)^2 - 4d(D_{\text{obj}} - d)} \right] \quad (\text{C.2})$$

where  $s_t$  is the total sound path.

## C.2.2 Half skip

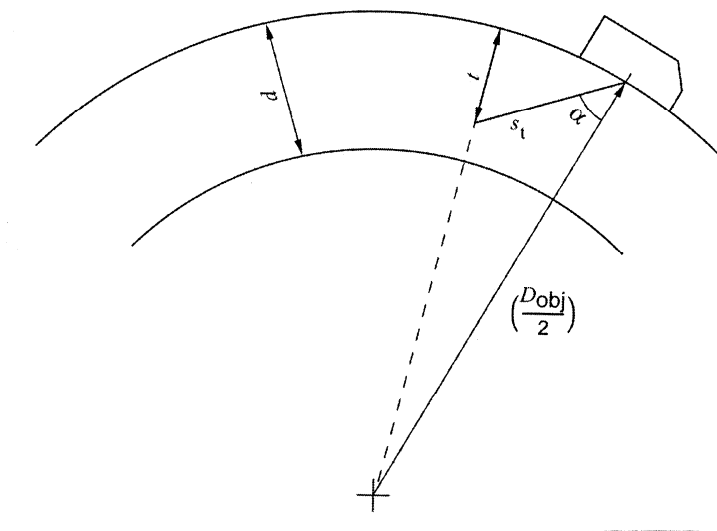

Figure C.3 — Determination of sound path distance for scanning from the outer surface in half skip

$$s_t = \left(\frac{t}{2d}\right) \left[ (D_{\text{obj}} \cos \alpha) - \sqrt{(D_{\text{obj}} \cos \alpha)^2 - 4d(D_{\text{obj}} - d)} \right] \quad (\text{C.3})$$

where  $s_t$  is the total sound path.

### C.3 Soundpath when scanning from the inner (concave) surface:

$$s = -2 \left[ \left( \frac{D_{\text{obj}}}{2} - d \right) \cos \alpha - \sqrt{\left[ \left( \frac{D_{\text{obj}}}{2} - d \right) \cos \alpha \right]^2 + d(D_{\text{obj}} - d)} \right] \quad (\text{C.4})$$

#### C.3.1 Full skip

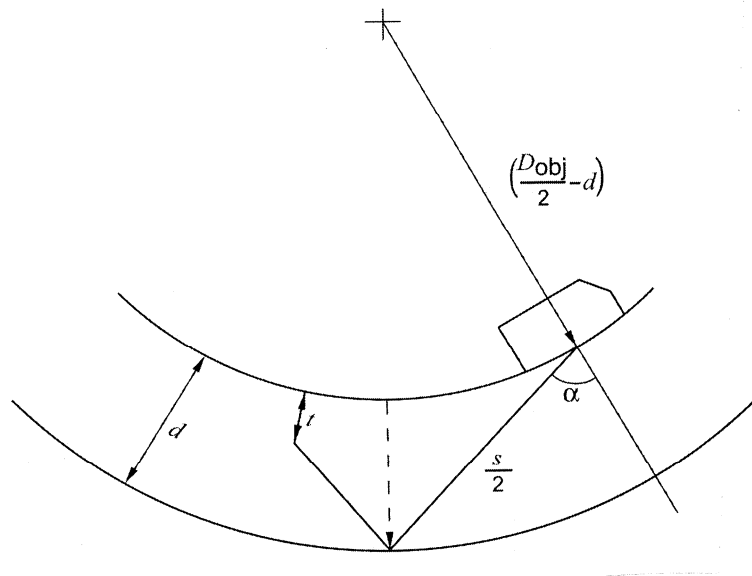

Figure C.4 — Determination of sound path distance for scanning from the inner surface in full skip

$$s_t = -2 \left( 1 - \left( \frac{t}{2d} \right) \right) \left[ \left( \frac{D_{\text{obj}}}{2} - d \right) \cos \alpha - \sqrt{\left[ \left( \frac{D_{\text{obj}}}{2} - d \right) \cos \alpha \right]^2 + d(D_{\text{obj}} - d)} \right] \quad (\text{C.5})$$

where  $s_t$  is the total sound path.

## ISO 16811:2012(E)

## C.3.2 Half skip

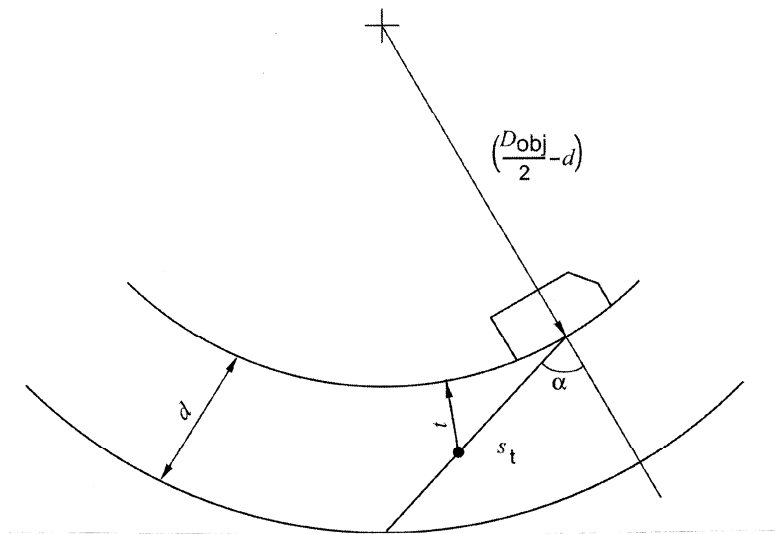

Figure C.5 — Determination of sound path distance for scanning from the inner surface in half skip

$$s_t = \left(\frac{t}{d}\right) \left[ \left(\frac{D_{obj}}{2} - d\right) \cos \alpha - \sqrt{\left[\left(\frac{D_{obj}}{2} - d\right) \cos \alpha\right]^2 + d(D_{obj} - d)} \right] \quad (C.6)$$

where  $s_t$  is the total sound path.

## Annex D (informative)

### General DGS diagram

This is a theoretically derived diagram applicable to all single transducer, straight or angle beam probes having a known natural focus (effective near field length  $N_{\text{eff}}$ ). It expresses the relationship between echo height or gain (in dB), and the sound path distance expressed in near field lengths for the probe in use, for a series of disk-shaped reflectors. The size of the reflectors is expressed in terms of the effective transducer diameter  $D_{\text{eff}}$  of the probe in use. The general DGS Diagram is shown in Figure 10.

#### D.1 Distance

The normalized distance,  $A$ , is given by the equation

$$A = \frac{s + s_d}{N_{\text{eff}}} \quad (\text{D.1})$$

and

$$s_d = l_d \left( \frac{c_d}{c_t} \right) \quad (\text{D.2})$$

where

$s$  is the sound path distance to reflector;

$s_d$  is the equivalent sound path distance in the delay block of the probe;

$N_{\text{eff}}$  is the near field length of probe in test object;

$l_d$  is the length of delay path;

$c_d$  is the longitudinal wave velocity in delay block;

$c_t$  is the wave velocity in test object.

For straight beam probes without a delay block the equation simplifies to

$$A = \frac{s}{N_{\text{eff}}} \quad (\text{D.3})$$

#### D.2 Gain

The gain,  $V$ , is the logarithmic value of the ratio between echo height on the screen ( $[H_R]_{A \rightarrow 0}$ ) for a large planar reflector (e. g. backwall) situated immediately in front of the transducer, and the echo height ( $[H_{\text{DSR}}]_A$ ) of a disk-shaped reflector at distance  $A$ .

$$V = -20 \log_{10} \left( \frac{[H_R]_{A \rightarrow 0}}{[H_{\text{DSR}}]_A} \right) \quad (\text{D.4})$$

**ISO 16811:2012(E)**

In general, the gain difference,  $\Delta V$ , between two echoes is determined by noting the change in gain setting of the instrument necessary to bring both echoes to the same height on the screen.

**D.3 Size**

The normalized size,  $G$ , of a reflector is expressed in terms of the ratio of the actual diameter of a disk-shaped reflector,  $D_{\text{DSR}}$ , to that of the effective transducer diameter,  $D_{\text{eff}}$ , of the probe in use.

$$G = \frac{D_{\text{DSR}}}{D_{\text{eff}}} \quad (\text{D.5})$$

## Annex E (informative)

### Determination of contact transfer correction factors

#### E.1 General

As usual the gain  $V$  in decibels is given by:

$$V = 20 \log_{10}(A/A_0) \quad (\text{E.1})$$

where  $A$  and  $A_0$  are signal amplitudes.

During propagation a sound wave suffers from three different losses:

- Divergence losses  $V_D$  caused by the probe and the material.  
With distance the sound pressure decreases. Curves are shown e. g. in the DGS diagram (Figure 10);
- Attenuation losses  $V_A$  caused by the material of the test object (absorption and scattering).  
Usually sound pressure decreases with distance following an exponential function;
- Contact transfer losses  $V_{CT}$  caused by the contact matching of the probe to the test object via a coupling fluid.  
Every time the reflected sound wave passes this area, part of the energy enters the probe and the other part is reflected back for further multiple echoes (see Figure E.1).

#### E.2 Measurement

To measure these contact transfer losses, which are not constant but depend on distance, the divergence losses  $V_D$  and attenuation losses  $V_A$  have to be eliminated.

To keep these losses  $V_A$  and  $V_D$  constant during the measurement, a set of at least three plane parallel plates made of the same material are used with the same probe under constant coupling conditions (fluid, load, rest time, temperature). The thicknesses  $t_1, t_2, t_3$  of these plates have the ratios  $t_3 = 2t_2 = 4t_1$ .

Using plate 1 with thickness  $t_1$ , four echoes are generated with the amplitudes  $V_1(t_1), V_1(2t_1), V_1(3t_1), V_1(4t_1)$ , which are noted.

Similarly, plate 2 with thickness  $t_2$  gives two echoes with the amplitudes  $V_2(t_2), V_2(2t_2)$ .

Finally the first echo from plate 3 with thickness  $t_3$  gives an amplitude  $V_3(t_3)$ .

#### E.3 Evaluation

The second echo from plate 2 with thickness  $t_2$  and the first echo from plate 3 with thickness  $t_3$  have the same sound path length, therefore their losses  $V_A$  and  $V_D$  are equal.

The difference of their dB-readings give the contact transfer loss at distance  $t_2$ :

$$V_2(2t_2) - V_3(t_3) = V_{CT}(t_2) \quad (\text{E.2})$$

## ISO 16811:2012(E)

The second echo from plate 1 with thickness  $t_1$  and the first echo from plate 2 with thickness  $t_2$  give the contact transfer loss at distance  $t_1$ :

$$V_1(2t_1) - V_2(2t_2) = V_{CT}(t_1) \quad (\text{E.3})$$

The fourth echo from plate 1 with thickness  $t_1$  and the first echo from plate 3 with thickness  $t_3$  have also equal losses  $V_A$  and  $V_D$ , but the measured value  $V_1(4t_1)$  includes the contact transfer losses at three different distances:  $t_1, 2t_1, 3t_1$ .

The losses at  $t_1$  and  $2t_1=t_2$  have already been determined by equations (E.2) and (E.3). So the unknown loss  $V_{CT}(3t_1)$  can be calculated by:

$$V_1(4t_1) - V_3(t_3) - V_{CT}(t_1) - V_{CT}(t_2) = V_{CT}(3t_1) \quad (\text{E.4})$$

With these three values for the contact transfer losses at three different distances a graph can be plotted as Figure E.2 shows.

Contact transfer losses for all distances between  $0,5t_1$  and  $3,5t_1$  can be read off the diagram without further measurement.

They are only valid for the used combination of probe, coupling fluid and material.

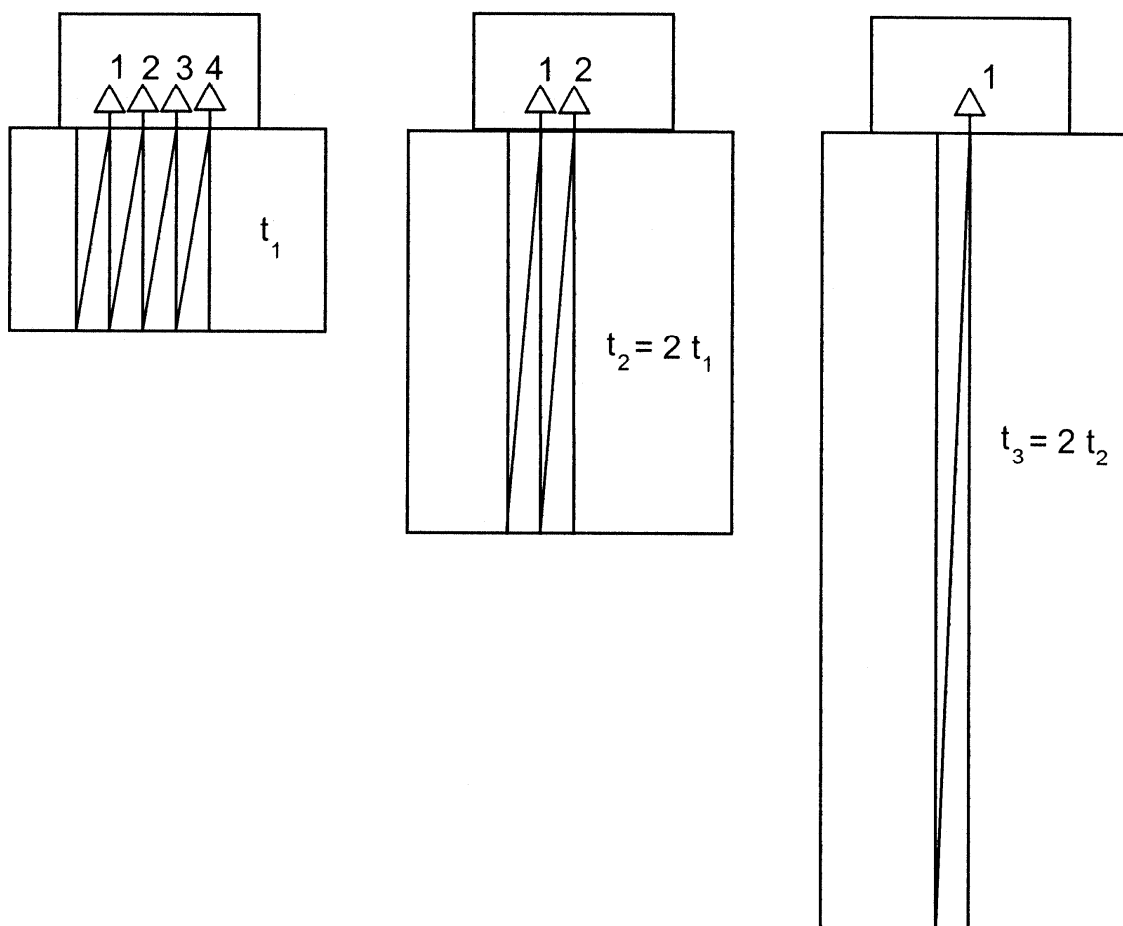
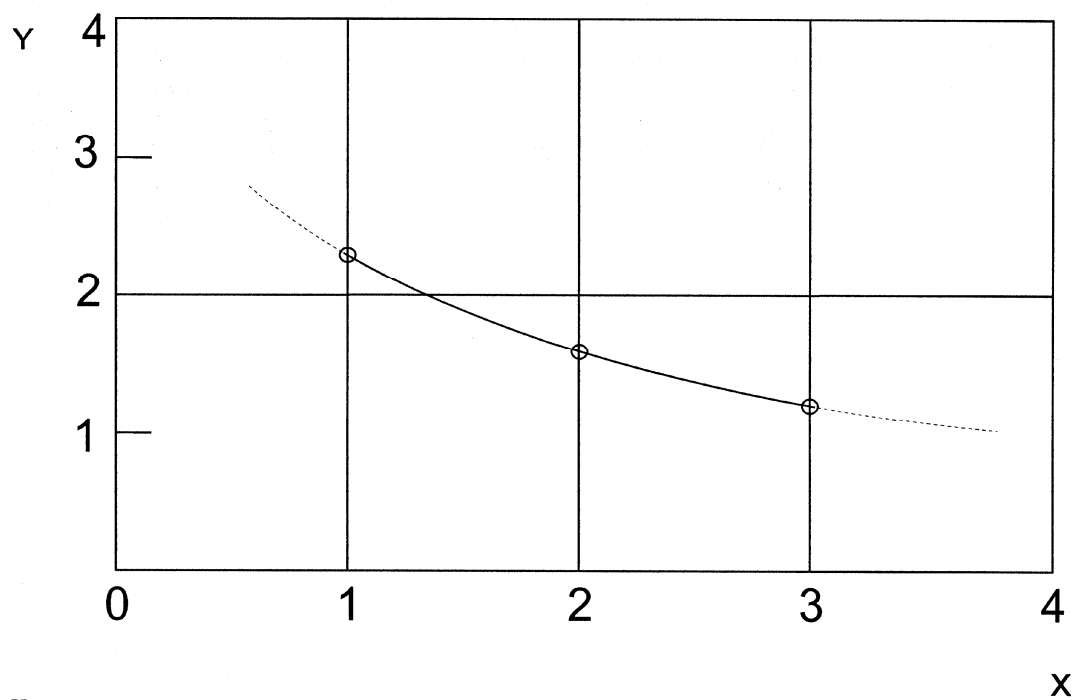

Figure E.1 — Setup for determination of contact transfer losses

**Key**

$y$  contact transfer loss  $V_{CT}$  in dB

$x$  sound path distance in multiples of  $t_1$

**Figure E.2 — Determination of contact transfer losses**

ISO 16811:2012(E)

## Bibliography

- [1] ISO 16826, *Non-destructive testing — Ultrasonic testing — Examination for discontinuities perpendicular to the surface*
- [2] ISO 16828, *Non-destructive testing — Ultrasonic testing — Time-of-Flight Diffraction Technique as a method for detection and sizing of discontinuities*



**ISO 16811:2012(E)**

---

---

**ICS 19.100**

Price based on 38 pages